

# ECHOMAX

## RTE Active Waterproof Control Box

### INSTALLATION AND OPERATION

The waterproof control box has been designed for owner installation. If, however, you do not feel confident seek the help of a professional. Select a position for the backing plate on a bulkhead or steering console and drill or cut a 57mm hole as shown on the template supplied overleaf making sure that there are no existing wires behind the proposed installation.

Fit cable glands to the rear section and feed the RTE, power and extension wiring through them remembering to keep the two cable glands at the top so they are level with the PCB connectors. If no extension alarm is being fitted blank the single lower hole with the blanking plug and gasket provided. For ease of attaching the wiring as shown on page two use thin nose pliers to remove and replace the green male terminal connectors after the wires have been firmly attached. Only leave sufficient inner cables so that the back plate can be fixed in position.

Gently tighten waterproof glands.

Check that the O ring is in place and press the front of the control to the backing plate until the two pop together and are flush.

Attach the front section to the back plate using the four Allen screws and the Allen key provided.

#### Dimensions

Length: 90mm Width: 72mm Depth: 15mm

Cut out diameter is 57mm

Overall depth 50mm (ex provision for cables)

#### Power

To turn the unit on press the "Power" button, the RED power indicator will illuminate continuously.

To turn the unit off press the "Power" button, the RED power indicator will turn off.

#### Internal Audible Alarm

Pressing the "Alarm" button will toggle the internal audible alarm on and off.

When the internal audible alarm is enabled the BLUE alarm indicator is turned off.

When the internal audible alarm is disabled the BLUE alarm indicator is illuminated.

The status of the internal audible alarm is stored in NVM and is retained for use after power cycling the unit.

*Note: the factory default setting is internal alarm enabled.*

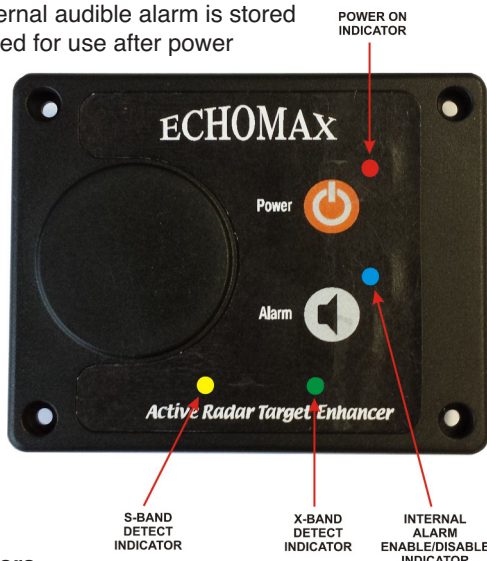

Fig. 1:  
Active control box indicators

#### S & X-Band Indicators

The toggling of the internal alarm does not affect the operation of the S-Band (YELLOW) or the X-Band (GREEN) indicators. These indicators will illuminate each time the RTE is hit with the relevant RADAR pulse.

#### Audible Alarm Sensitivity

The sensitivity of the audible alarm is user adjustable and can be set to 1 of 7 different levels. The sensitivity setting will determine the amount of RADAR activity, measured in milliseconds within a 3 second window, required to sound the audible alarm.

To enter into the alarm sensitivity adjustment mode, press and hold the "Alarm" button for 5 seconds until the internal speaker emits a tone.

Subsequent presses of the "Alarm" button will increase the sensitivity level, which is indicated by the pitch of the tone emitted by the internal speaker, refer to Table 1 below.

Sensitivity Level	Tone Frequency	ms of Activity in 3 sec
1 (least sensitive)	500Hz	250
2	550Hz	200
3	600Hz	150
4	650Hz	100
5	700Hz	50
6	750Hz	20
7 (most sensitive)	750Hz	20

Table 1: Alarm sensitivity chart

Once the level has reached 7 a further press of the "Alarm" button will cause the sensitivity level to return to level 1. Once the required sensitivity level has been reached the mode will time out after 2 seconds of the last "Alarm" button press and return to normal operation using the chosen sensitivity setting. The sensitivity setting is stored in NVM and is retained for use after power cycling the unit.

*Note: the factory default setting is level 6.*

#### Illumination

The brightness of the indicators can be adjusted for day and night vision.

To adjust the illumination level of the indicators, press and hold the "Alarm" button for 2 seconds; release the button and the illumination level will change.

The illumination level is stored in NVM and is retained for use after power cycling the unit.

*Note: the factory default setting is day mode (the brightest level).*

#### Connectivity

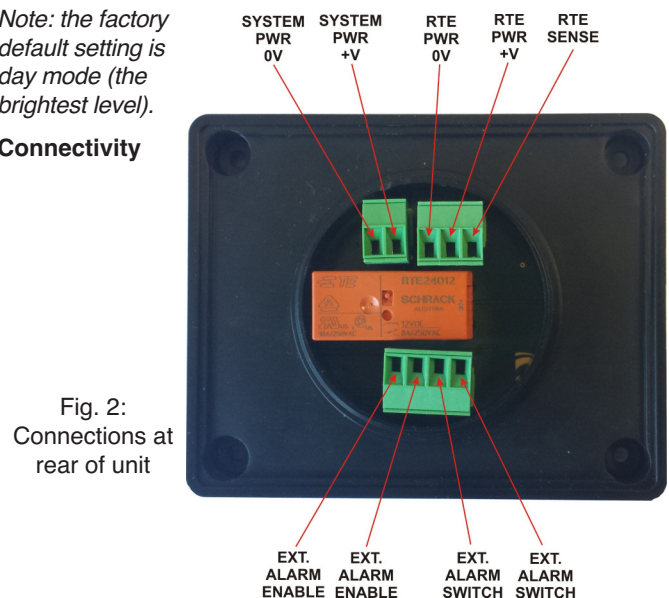
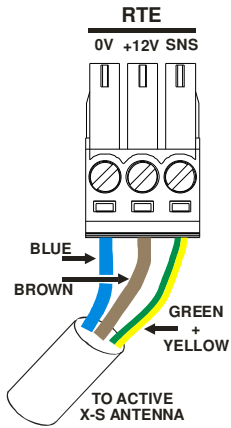
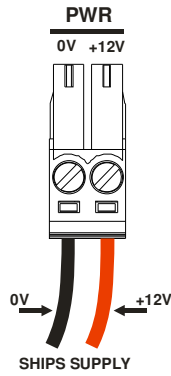

Fig. 2:  
Connections at rear of unit

**Power Connections**

Use the 2 way terminal connector provided to connect the unit to the ships supply. Ensure the connector is wired as indicated in Fig. 3.

Fig. 3: Power supply



**RTE Connections**

Use the 3 way terminal connector provided to connect the unit to the active X-S antenna. Ensure the connector is wired as indicated in Fig. 4. If an X Band RTE is being wired just connect the blue and brown wires.

Fig. 4: RTE connectivity

**External Alarm Connections**

The unit has the ability to supply a switched signal for an external alarm. This alarm will operate along with the internal audible alarm. Use the 4 way terminal connector, provided, to connect the unit to the external alarm. Ensure the connector is wired as indicated in Fig. 5. The "EXT ALARM" connections are a switched relay. The user must provide an external signal to be switched through these relay connections.

To enable the external alarm the "EXT ALARM ENABLE" connections must be linked together. It is suggested that this link is made through a toggle switch to provide a means of disabling the external alarm.

*Note: disabling the internal audible alarm WILL NOT affect the external alarm.*

**EXTERNAL ALARM**

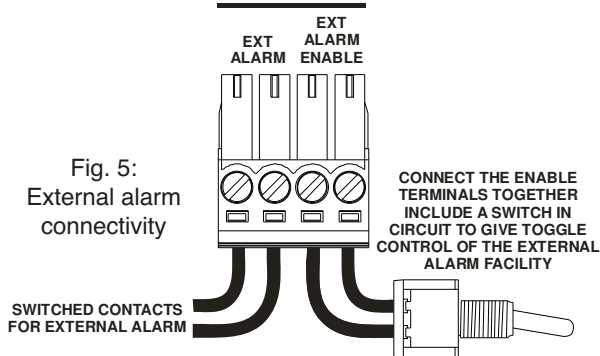

Fig. 5: External alarm connectivity

**Using Dual Control Boxes with Active-X & X-S RTE**

The standard control box may be dual stationed to an exterior waterproof one as shown below.

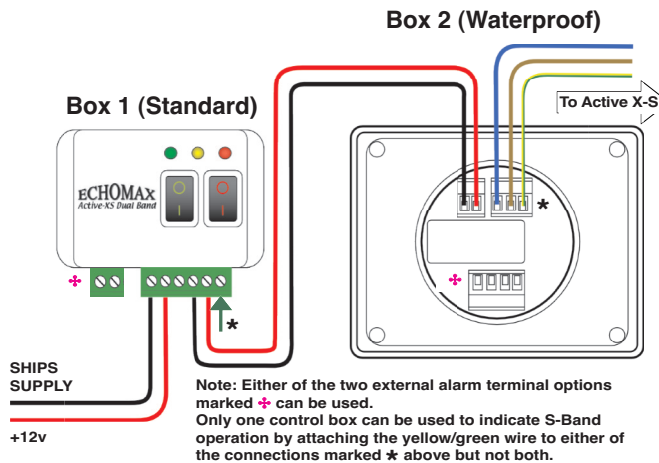

Fig. 6: Dual station connection

Note: If the alarm is active on Box 2 the Green LED indicator on Box 1 will show an extended flash whenever a radar pulse is detected. For correct indication, it is suggested to use the alarm on Box 1 only.

When using an external alarm, the alarm should be wired to Box 1, as shown in Figure 7.

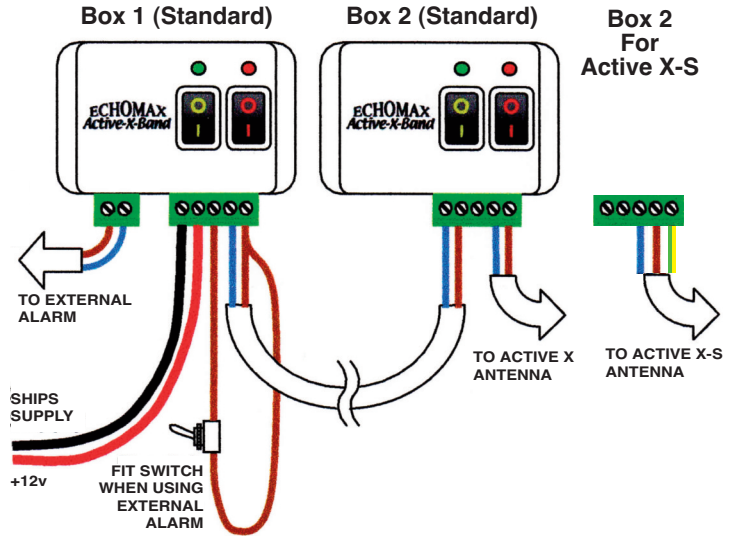
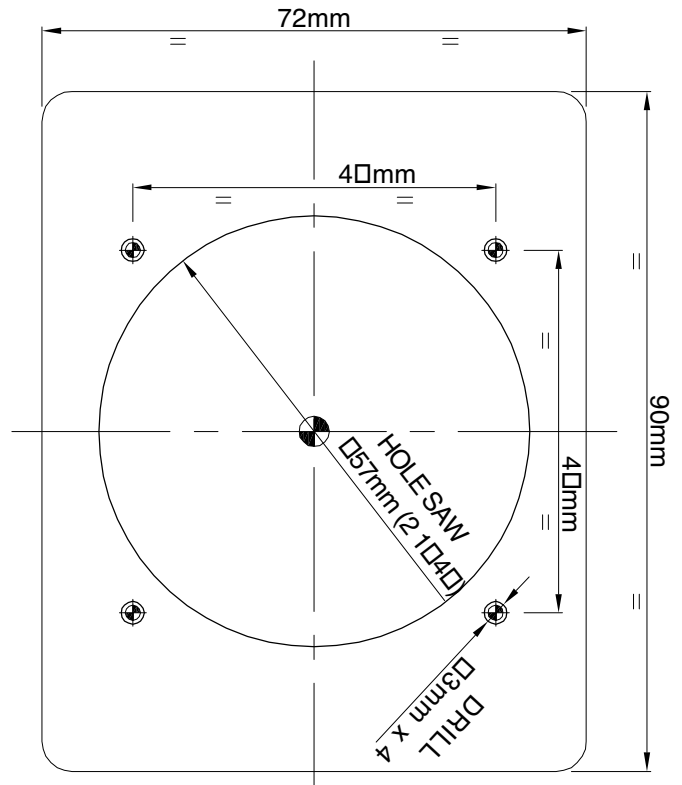

Fig. 7: Connection of External Alarm

For further information on wiring external alarms, see the Active-X and ActiveX-S Operation Manuals

**Cutting Template**



**Manufactured by**  
**Echomax Products in the UK**  
**PO Box 6032, Dunmow CM6 3AS, UK.**  
**Email: echomaxsales@aol.com www.echomax.co.uk**  
**Tel: 00 44 (0) 1371 830216 Fax: 831733**