

KVH Industries, Inc.

TracPhone® FB150



Installation Guide

TracPhone FB150

Installation Guide

The KVH® Industries' TracPhone® FB150 system, manufactured by Thrane & Thrane, delivers high-speed data and voice communications via satellite through Inmarsat's Broadband Global Area Network (BGAN). This installation guide provides all of the information you need to install or service the system. For detailed operation information, please refer to the User's Guides.



Please direct technical questions to:

North/South America, Australia:

KVH Industries, Inc.
50 Enterprise Center
Middletown, RI 02842-5279 USA
Tel: +1 401 847-3327
Fax: +1 401 845-8133
E-mail: techs@kvh.com
Internet: www.kvh.com

Europe, Middle East, Asia:

KVH Europe A/S
Kokkedal Industripark 2B
2980 Kokkedal, Denmark
Tel: +45 45 160 180
Fax: +45 45 160 181
E-mail: support@kvh.dk
Internet: www.kvh.com

If you have any comments regarding this manual, please e-mail them to manuals@kvh.com. Your input is greatly appreciated!



KVH Part # 54-0644 Rev. A
© 2009, KVH Industries, Inc., All rights reserved.



Trademark Information

TracPhone, TracVision, KVH, and the unique light-colored dome with contrasting baseplate are registered trademarks of KVH Industries.

Thrane & Thrane is a registered trademark of Thrane & Thrane A/S in the European Union and the United States.

SAILOR is a registered trademark of Thrane & Thrane A/S in the European Union, the United States, and other countries.

Windows and Outlook are registered trademarks of Microsoft Corporation in the United States and other countries.

Inmarsat is a registered trademark of International Maritime Satellite Organisation (IMSO) and is licensed by IMSO to Inmarsat Limited and Inmarsat Ventures plc.

Inmarsat's product names are trademarks or registered trademarks of Inmarsat.

All other trademarks are the property of their respective owners.

Disclaimer

Every effort has been made to ensure the correctness and completeness of the material in this document. No company shall be liable for errors contained herein. The information in this document is subject to change without notice. No warranty of any kind is made with regard to this material, including, but not limited to, the implied warranties of merchantability and fitness for a particular purpose.

Safety summary

The following general safety precautions must be observed during all phases of operation, service and repair of this equipment. Failure to comply with these precautions or with specific warnings elsewhere in this manual violates safety standards of design, manufacture and intended use of the equipment. KVH assumes no liability for the customer's failure to comply with these requirements.

Observe marked areas

Under extreme heat conditions do not touch areas of the terminal or antenna that are marked with this symbol, as it may result in injury.



Microwave radiation hazards

During transmission the antenna in this system radiates microwave power. This radiation may be hazardous to humans close to the antenna. During transmission, make sure that nobody gets closer than the recommended minimum safety distance.

On the TracPhone FB150, the minimum safety distance on the focal line to the antenna panel is 0.6 m, based on a radiation level of 10 W/m^2 . The radiation level is 100 W/m^2 at a distance of 0.2 m from the antenna panel. Refer to the drawing below.

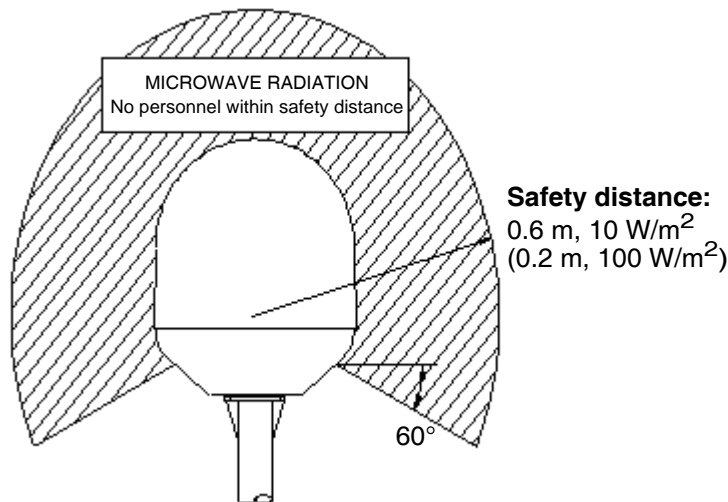

Distance to other equipment

Do not move the antenna closer to radars than the minimum safe distance specified in *Radar distance* on page 7 - it may cause damage to the antenna. The equipment must be installed with the following minimum safe distances to magnetic steering compass:

TracPhone FB150 terminal: min. 0.3 m.

TracPhone FB150 antenna: min. 1.1 m

Service

Access to the interior of the system units is prohibited - failure to comply with this rule will void the warranty.

Do not service or adjust alone

Do not attempt internal service or adjustments unless another person, capable of rendering first aid resuscitation, is present.

Grounding, cables and connections

To minimize shock hazard, the equipment chassis and cabinet must be connected to an electrical ground. The terminal must be grounded to the ship. For further grounding information refer to *Grounding and RF protection* on page 56.

Do not extend the cables beyond the lengths specified for the equipment. The cable between the terminal and antenna can be extended if it complies with the specified data concerning cable losses etc.

All cables for your TracPhone system are shielded and should not be affected by magnetic fields. However, try to avoid running cables parallel to AC wiring as it might cause malfunction of the equipment.

Power supply

The voltage range is 10.5 - 32 V DC; 14 A - 5.5 A. It is recommended that the voltage is provided by the 24 V DC power bus on the ship. Be aware of high start-up peak current: 20 A at 24 V, 5 ms.

If a 24 V DC power bus is not available, an external 115/230 VAC to 24 V DC power supply can be used.

Do not operate in an explosive atmosphere

Do not operate the equipment in the presence of flammable gases or fumes. Operation of any electrical equipment in such an environment constitutes a definite safety hazard.

Keep away from live circuits

Operating personnel must not remove equipment covers. Component replacement and internal adjustment must be made by qualified maintenance personnel. Do not replace components with the power cable connected. Under certain conditions, dangerous voltages may exist even with the power cable removed. To avoid injuries, always disconnect power and discharge circuits before touching them.

Failure to comply with the rules above will void the warranty!

About the manual

Intended readers

This is an installation manual for the TracPhone FB150 system. The readers of the manual include installers of the system and service personnel. Personnel installing or servicing the system must be properly trained and authorized by KVH. It is important that you observe all safety requirements listed in the beginning of this manual, and install the system according to the guidelines in this manual.

Manual overview

Note that this manual does not cover general use of the system nor does it cover how to use the IP handset that comes with the system. For this information, refer to the user manual for this system and the user manual for the IP handset, both listed in the next section.

This manual has the following chapters:

- *System units* contains a short description of each main unit in the system.
- *Installing the system* describes where to place the system units, how to mount them, distance to other equipment etc.
- *Connecting power* explains how to connect the terminal to power and gives recommendations for cables.
- *Hardware interfaces* describes each interface on the terminal and shows pin-out for the connectors.
- *Starting up the system* explains how to insert the SIM card, power up the system and enter the PIN. It also gives a short overview of how to use the system.
- *Troubleshooting* describes the function of the Reset button and the light indicator on the terminal. It also describes event messages that may appear in the web interface.

Related documents

The below list shows the documents related to this manual and to the system.

Title and description	Document number
TracPhone FB150 User Manual Explains how to set up and use the TracPhone FB150 system.	54-0645
TracPhone FB150 Quick Reference Guide A short guide to the most important functions of the TracPhone FB150 system.	54-0642
TracPhone IP Handset, User Manual Explains the features and functions of the TracPhone IP Handset. The TracPhone IP handset works as a standard IP handset, but also serves as a user interface for the TracPhone FB150 system.	34-126059

Typography

In this manual, typography is used as indicated below:

Bold is used for the following purposes:

- To emphasize words.
Example: "Do **not** touch the antenna".
- To indicate what the user should select in the user interface.
Example: "Select **Settings** > **LAN**".

Italic is used to emphasize the paragraph title in cross-references.

Example: "For further information, see *Connecting Cables* on page...".

Table of contents

Chapter 1	System units	
	Introduction	1
	TracPhone FB150 terminal	1
	TracPhone FB150 antenna	2
	TracPhone IP Handset & Cradle	3
Chapter 2	Installing the system	
	Unpacking	4
	Placing the antenna	5
	Installing the antenna	12
	Placing the terminal	15
	Installing the terminal	16
Chapter 3	Connecting power	
	Power source	19
	Power cable selection	19
	Connecting power	22
Chapter 4	Hardware interfaces	
	The connector panel	24
	Antenna interface on terminal	25
	DC power input	26
	Ground stud	27
	Analog Phone interface	28
	LAN interface	29
	Discrete I/O interface	31
Chapter 5	Starting up the system	
	Using the SIM card	33
	Powering the system	35
	Entering the SIM PIN for the terminal	37
	Operating the system	39
Chapter 6	Troubleshooting	
	Reset button	40
	Status signaling	42
	Logging of events	43
Appendix A	Part numbers	
	System units	44
	Spare parts	44

Appendix B Technical specifications

Overview	45
TracPhone FB150 antenna	45
TracPhone FB150 terminal	51
Measuring the ship source impedance	55

Appendix C Grounding and RF protection

Why is grounding required?	56
About marine DC systems	57
About marine grounding	59
Grounding Recommendations	60
Alternative grounding for steel hulls	61
Alternative grounding for aluminum hulls	63
Alternative grounding for fiberglass hulls	64
Alternative grounding for timber hulls	65
Separate ground cable	66
RF interference	69
Electrostatic Discharge	69

Glossary	70
-----------------------	----

Index	73
--------------------	----

System units

Introduction

The basic system consists of three units: The terminal, the antenna and the IP handset with cradle.

Note | The TracPhone FB150 terminal only works with a TracPhone FB150 antenna.

TracPhone FB150 terminal

The terminal is the central unit in the system. It contains all user interfaces and handles all communication between the BGAN antenna and the local communication units (phones, computers etc.).



The terminal supplies 18-29 V DC to the antenna through a single coaxial cable. The DC input for the terminal is designed for both 24 V DC and 12 V DC power supply.

TracPhone FB150 antenna

The TracPhone FB150 antenna is a BGAN mechanical tracking antenna. All communication between the antenna and terminal passes through a single coaxial cable. The antenna unit is protected by a thermo-plastic radome.

The TracPhone FB150 antenna is housed in either of the following dome sizes:

- 10.8" (27.6 cm) compact dome
- 13.5" (34.3 cm) dome, which matches the TracVision® M1 satellite TV antenna



TracPhone IP Handset & Cradle



IP Handset

Besides the normal functions of an IP handset, it also provides a user interface for the TracPhone system. The IP handset connects to the LAN interface of the terminal, and is power supplied with Power over Ethernet (PoE) through the LAN interface.

For further information on the IP handset, refer to the user manual for the IP handset.

IP Cradle

The IP cradle serves as a holder for the IP handset. It is power supplied from the terminal using Power over Ethernet (PoE). The cradle connects to the handset with a coil cord and to the terminal with a standard LAN cable.

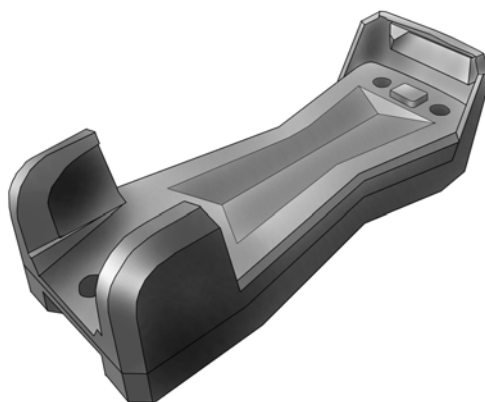

Installing the system

Unpacking

Unpack your TracPhone system and check that the following items are present:

- TracPhone FB150 terminal
- TracPhone FB150 antenna
- TracPhone IP handset & cradle, wired
- Power cable
- Antenna cable
- LAN cable
- Customer Welcome Kit including:
 - Quick Reference Guide
 - TracPhone FB150 Documentation CD including electronic versions of User's Guide, Installation Guide and IP Handset User's Guide.

Inspect all units and parts for possible transport damage.

Note

For information on how to install the IP handset and cradle, refer to the user manual for the handset.

Important

Upon installing the TracPhone system, make sure the terminal and IP handset have the latest software installed. The latest software versions are available to KVH dealers and distributors on the KVH Partner Portal. The latest version of terminal software can also be downloaded over the satellite link (see the User's Guide for details). Refer to the User's Guide and IP Handset User's Guide for complete instructions on uploading new software versions to the units.

Placing the antenna

Obstructions

The antenna rotates 360° and down to -60° in pitch and roll, to allow for continuous pointing even in heavy sea conditions. Any obstructions within this volume can cause signal degradation.

The amount of degradation depends on the size of the obstruction and the distance from the antenna. As a rule of thumb any obstruction that subtends an angle of less than 3° at the antenna has limited effect. The table below gives a guideline for obstruction sizes that will cause limited degradation.

Distance of Obstruction	Size of Obstruction
3 m	16 cm
5 m	26 cm
10 m	52 cm
20 m	104 cm

Radiation hazard

The TracPhone FB150 antenna radiates 16.1 dBW EIRP. This translates to a minimum safety distance of 0.6 m from the antenna while it is transmitting, based on a radiation level of 10 mW/cm².

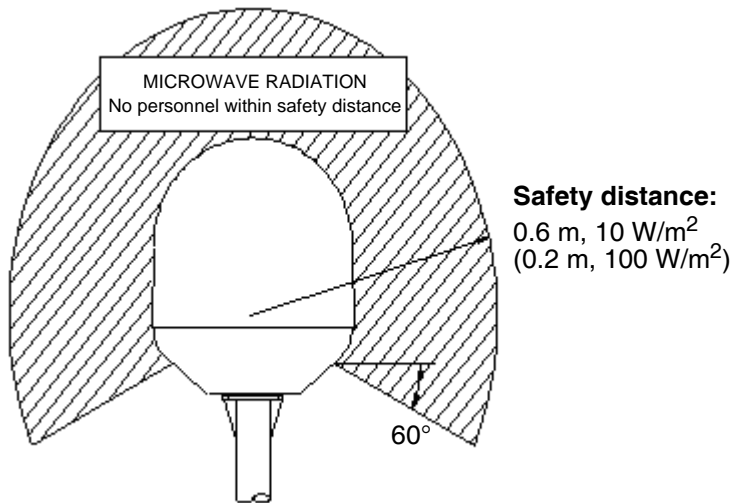

Interference

Overview

The antenna must be mounted as far away as possible from the ship's radar and high power radio transmitters (including other Inmarsat based systems), because they may compromise the antenna performance. RF emission from radars might actually damage the antenna.

The TracPhone antenna itself may also interfere with other radio systems. Especially other Inmarsat systems and GPS receivers with poor frequency discrimination are vulnerable to the radiation generated by the TracPhone antennas.

Radar

It is difficult to give exact guidelines for the minimum distance between a radar and the antenna because radar power, radiation pattern, frequency and pulse length/shape vary from radar to radar. Further, the antenna is typically placed in the near field of the radar antenna and reflections from masts, decks and other items in the vicinity of the radar are different from ship to ship.

However, it is possible to give a few guidelines:

Since a radar radiates a fan beam with a horizontal beam width of a few degrees and a vertical beam width of up to $\pm 15^\circ$, the worst interference can be avoided by mounting the antenna at a different level – meaning that the antenna is installed minimum 15° above or below the radar antenna. Due to near field effects the benefit of this vertical separation could be reduced at short distances (below approximately 10 m) between radar antenna and the TracPhone antenna. Therefore it is recommended to ensure as much vertical separation as possible when the TracPhone antenna has to be placed close to a radar antenna.

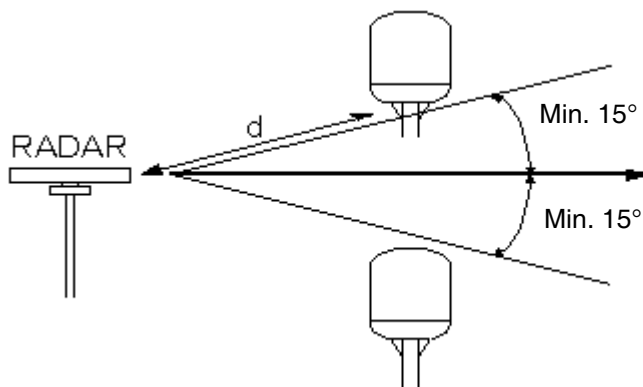

Radar distance

The minimum acceptable separation (d_{\min}) between a radar and the antenna is determined by the radar wavelength/frequency and the power emitted by the radar. The tables below show some “rule of thumb” minimum separation distances as a function of radar power at X and S band. If the d_{\min} separation listed below is applied, antenna damage is normally avoided.

“ d_{\min} ” is defined as the shortest distance between the radar antenna (in any position) and the surface of the TracPhone antenna.

X-band (~ 3 cm / 10 GHz) damage distance		
Radar power	d_{\min} at 15° vertical separation	d_{\min} at 60° vertical separation
0 – 10 kW	0.8 m	0.4 m
30 kW	2.4 m	1.2 m
50 kW	4.0 m	2.0 m

S-band (~ 10 cm / 3 GHz) damage distance		
Radar power	d_{\min} at 30° vertical separation	d_{\min} at 75° vertical separation
0 – 10 kW	0.4 m	0.2 m
30 kW	1.0 m	0.5 m
50 kW	2.0 m	1.0 m

The separation distance for C-band (4-8 GHz) radars should generally be the same as for X-band radars.

Interference

Even at distances greater than “ d_{\min} ” in the previous section the radar might still be able to degrade the performance of the TracPhone system.

The presence of one or more X-band radars within a radius up to 100 m could cause a minor degradation of the signal-to-noise ratio during high speed and data calls. The degradation will be most significant at high radar pulse repetition rates.

As long as receiving conditions are favorable, this limited degradation is without importance. However, if receiving conditions are poor – e.g. due to objects blocking

the signal path, heavy rainfall or icing, low satellite elevation and violent ship movements – the small extra degradation due to the radar(s) could cause poor call quality. A voice call might become noisy and perhaps fail while a data connection might decrease in speed and performance.

The presences of S-band radar(s) are unlikely to cause any performance degradation – as long as the minimum distances (d min.) listed in the previous section are applied.

It is strongly recommended that interference free operation is verified experimentally before the installation is finalized.



CAUTION! The antenna must never be installed closer to a radar than “d min.” - even if experiments show that interference free operation can be obtained at shorter distances than “d min.” in the previous section.

Other Inmarsat systems

Recommended minimum safe distance to other Inmarsat antennas is 10 m.

GPS receivers

Good quality GPS receivers will work properly very close to the antenna - typically down to one meter outside the main beam, and down to a few meters inside the main beam. However, simple GPS receivers with poor frequency discrimination could be affected at longer range (typically 10 m). It is always recommended to test the GPS performance before the installation is finalized.

Other transmitters

See *Minimum distance to transmitters* on page 50 in Appendix B for minimum recommended distance to transmitters in the frequency range below 1000 MHz.

Other precautions

Do not place the antenna close to a funnel, as smoke deposits are corrosive. Furthermore, deposits on the radome can degrade performance.

Antenna mast design

Overview

The antenna mast must be designed to carry the weight of the antenna unit, which is approximately 8.6 lbs (3.9 kg) for the 10.8" (27.6 cm) compact dome, or 11.5 lbs (5.2 kg) for the 13.5" (34.3 cm) dome. Also be sure to take into account the 2.4 lbs (1.1 kg) weight of the mast mount kit.

The mast must also be able to withstand onboard vibrations and wind forces up to 108 knots on the radome, even in icing conditions.

Antenna mast mounting

Mast mount kit:

The top of the TracPhone FB150 antenna mast should be fitted with the dedicated mounting kit available from KVH Industries.

Assemble the mast mount kit according to the assembly instructions included with the kit.

The mast mount kit interfaces to a 1½" pipe (OD 48.3 mm). If the supplied plastic sleeve is omitted, a maximum diameter OD of 52 mm can be used.

Custom mast mounting:

For a custom mast mounting, use 4 M6 bolts (A4) in the threaded bushings on the 175.4 mm diameter circle in the bottom of the antenna. The length of the bolts must be such that they engage into the bushings of the radome with min. 6 mm and max. 12 mm. No drainage hole is necessary. Drill a hole for the cable or use an angled connector.

Mast length and diameter

The placement of the antenna must ensure a rigid structural connection to the hull or structure of the ship. Parts of the ship with heavy resonant vibrations are not suitable places for the antenna.

A small platform or short mast shall provide rigid support for the antenna fastening bolts and a rigid interface to the ship.

If it is necessary to use a tall mast, use the table on page 11 to obtain the maximum free length of the mast. Note that these values depend on rigid antenna-ship interfaces. The cross-sectional properties and the corresponding maximum free length give a natural frequency above 30 Hz.

It is recommended to shorten the mast length as much as possible to obtain higher frequencies. Alternatively, mount stays or wires to stabilize the mast further.

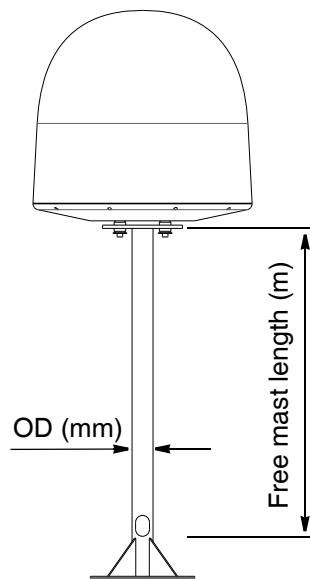

Note

The tables list the values for **steel masts**.

For **aluminium masts**, the free mast length is reduced to 75% of the values for steel.

High masts or installations on ships with high vibration levels should be further stabilized by stays or wires from the mast flange. Also mount vibration isolators between the flange and the radome. Vibration isolators are included in the mast mount kit.

Note

Stays and rigid masts can still not prevent vertical vibration if the mast is attached to a deck plate that is not rigid. Make every effort to mount the mast on a surface that is well supported by ribs. If this is not possible, provide extra deck plate propping.

Antenna mast length

The below table shows the values for a TracPhone FB150 antenna mast without stays or wires. Note that these values are only guidelines - always consider the environment and characteristics of the ship before deciding on the mast dimensions.

The mast mount kit interfaces to a 1½" tube (OD 48.3 mm - absolute maximum OD 52 mm). Masts with larger diameters must be tapered and the upper part of the tube (approximately 50 mm) must have a diameter of 1½".

OD (mm)	Wall Thickness (mm)	Weight (kg/m)	Inertia (X10 ⁶ mm ⁴)	Max. free mast length (steel), m
48.3	3.25	3.61	0.117	< 0.6
48.3	4.05	4.43	0.139	
50	3.00	3.48	0.123	
60.3	3.65	5.10	0.262	<0.8
60.3	4.50	6.17	0.309	
76.1	3.65	6.80	0.547	< 1.0
76.1	4.50	7.90	0.651	
88.9	4.05	8.47	0.974	< 1.1
88.9	4.85	10.10	1.140	

Installing the antenna

Antenna grounding

You may ground the antenna using the mounting bolts.

If the antenna cannot or should not be electrically connected directly to the mounting surface, you can use a separate grounding cable to make the connection between the antenna and the common ground to which the terminal is also connected. For example, you can connect a separate grounding cable when vibration isolators are used at the mounting bolts.

To obtain a good ground connection, the metal underneath the head of **at least** one bolt must be clean of insulating protective coating and a serrated washer should be used. After tightening the bolts we recommend that you seal the area suitably in order to avoid corrosion of the grounding point.

Use stainless steel bolts and washers.

For detailed grounding information, read *Grounding and RF protection* on page 56.

Antenna cables

Guidelines

A coaxial cable for connection between the antenna and terminal is delivered with the system. If you need a different cable, make sure that the cable meets the requirements. Preferably choose one of the cable types in *Recommended antenna cables* on page 13.

Select a suitable area for installation of the terminal, antenna and cradle. Where the cables are exposed to mechanical wear - on deck, through bulkheads, etc. - protect the cables with steel pipes. Otherwise, follow standard procedures for cabling in ship installations.

The maximum allowed RF-loss in the antenna cable is 20 dB at 1660 MHz. This is to ensure the performance of the system.

Recommended antenna cables

The table below shows recommended cable types and maximum cable lengths for TracPhone FB150.

Cable Type	Absolute maximum length
G02232-D	6 m
RG223-D	25 m
RG214/U	50 m
S 07272B-05	95 m

Check in the data sheet from the cable supplier that both the RF-attenuation and the DC-resistance are kept within the maximum specified values:

- Antenna cable RF-attenuation at 1660 MHz: max. 20 dB incl. connector.
- Antenna cable modem-attenuation at 54 MHz: max. 4 dB.
Antenna cable modem-attenuation at 36 MHz: max. 3 dB.
- Antenna cable loop DC-resistance max: 1 Ω .

Also ensure that the specified minimum bending radius is respected. If this is not the case, the loss in the cable will increase. Check the instructions from the cable supplier.

Important mounting notes

Line of sight

Place the antenna with free line of sight in all directions to ensure proper reception of the satellite signal. Do not place the antenna close to large objects that may block the signal.

Water intrusion

After having connected the antenna cable to the antenna - ensure that the connector assembly is properly protected against seawater and corrosion. As a minimum, use self-amalgamating rubber.

If possible, install the radome such that direct spray of sea water is avoided.

It is recommended not to use pneumatic tools for cleaning the radome, especially at a short distance and directly at the split between top and bottom.

Mounting the antenna

Overview

The antenna can now be installed on the ship with 4 stainless steel bolts fastened to the hull or to a mast. Make sure that you have chosen a suitable mounting location based upon the guidelines provided in the previous sections, and taking into account the antenna dimensions shown in *10.8" (27.6 cm) Dome* on page 48 or *13.5" (34.3 cm) Dome* on page 49.

For information on mast mounting, see *Antenna mast design* on page 9.

Mounting the antenna on the hull

Follow these steps to mount the antenna:

1. Make sure the antenna has a good line of sight to the satellites. When the antenna is mounted directly on the hull, it may be difficult to obtain line of sight, especially down to -60° , which is its maximum rotation angle (pitch and roll).
2. Align the base of the antenna with the front of the vessel as shown below.

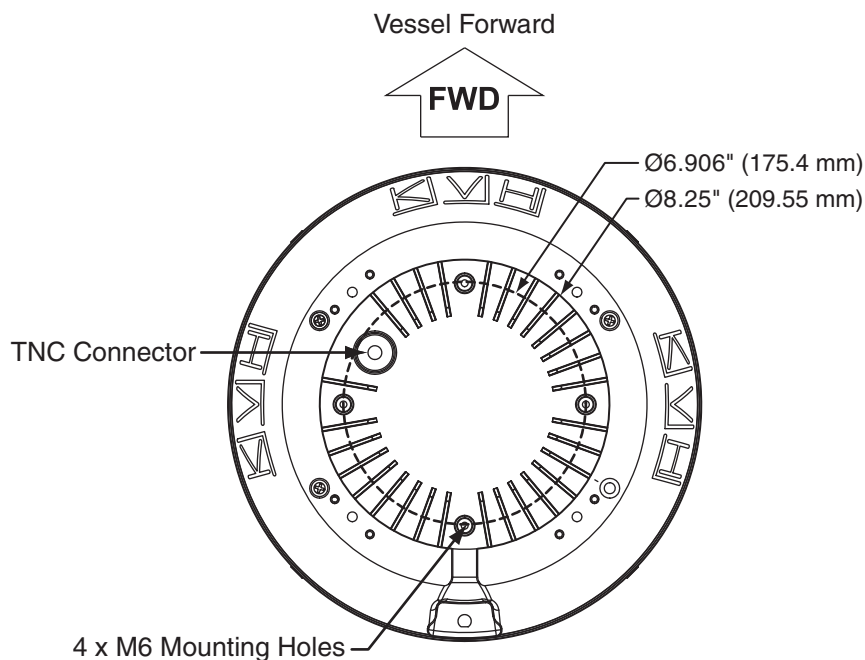

Note

This diagram shows the 13.5" (34.3 cm) dome. However, the mounting holes and connector for the compact dome are exactly the same.

3. Use M6 bolts for mounting the antenna. The bolt thread must not penetrate more than 12 mm (or 8 turns of the bolt) - and not less than 6 mm (or 4 turns of the bolt) - into the threaded part of the bushings in the bottom of the antenna. Fasten the bolts with 7-8 Nm torque.
4. Connect the antenna cable to the TNC connector on the bottom of the antenna.
5. See *Grounding and RF protection* on page 56 for details on grounding the antenna.

Placing the terminal

Where to place the terminal

Temperature conditions

The terminal must be placed in a ventilated area with free space around all sides of the unit, except the bottom side.

Ambient temperature range is -25°C to $+55^{\circ}\text{C}$.

If the terminal is installed in a location where the ambient temperature may exceed 50°C , we recommend placing the terminal where unintentional contact is avoided. If the maximum ambient temperature does not exceed 50°C , the terminal can be placed in a public area.

Grounding access

The terminal is designed with a case for bulkhead or desktop installation.

The case is equipped with mounting brackets, making it possible to secure the unit on a bulkhead.

Important The terminal must be placed in an area where access to the hull or equivalent grounding can be reached within 0.5 m.



Installing the terminal

Grounding the terminal

Antenna cable

The antenna is connected to the terminal by means of a coax cable with a TNC connector at both ends.

For information on antenna grounding, see *Antenna grounding* on page 12.

Ground stud

To ensure that the terminal is grounded – also if the cable is disconnected from the terminal, connect an extra ground wire to the ground stud on the terminal. This ground wire must be a heavy wire or braid cable with a larger diameter than the coax cable. The ground stud is located next to the power switch.

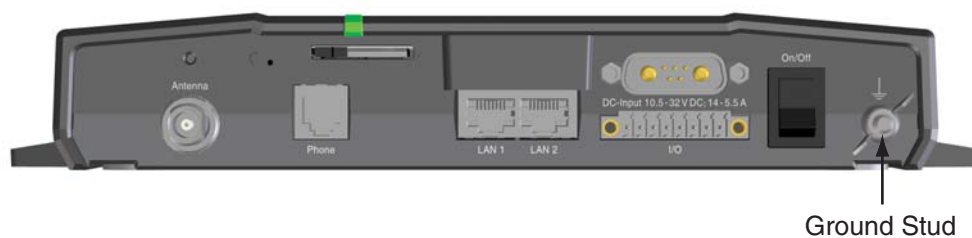

Mounting the basic cable support

The basic cable support is available from KVH.

When mounted on the terminal the basic cable support offers a number of holders to which you can secure the cables from the terminal, using tie-wraps.

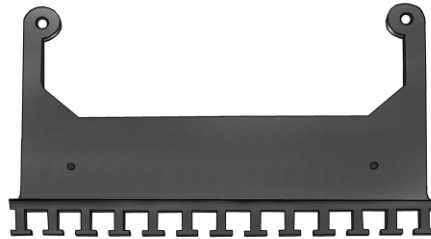

To mount the basic cable support, do as follows:

1. Remove the two rubber washers from the bottom of the terminal at the connector panel end. The threaded bushings underneath the rubber washers are used for mounting the cable support.



2. Fasten the basic cable support to the terminal using two M4 x 6 mm countersunk screws.



3. Install the terminal as described in *Installing the terminal on a bulkhead* on page 18 or *Installing the terminal on a desktop* on page 18.

Installing the terminal on a bulkhead

Terminal with no cable support

Do as follows to mount the terminal on a bulkhead:

1. Insert four screws through the holes in the mounting bracket and into the mounting surface. If the mounting surface is used for grounding, make sure that you have a good electrical connection to the surface.



2. Connect all cables.

Terminal with basic cable support

First mount the basic cable support on the terminal as described in *Mounting the basic cable support* on page 17.

1. Mount the terminal with the basic cable support on the bulkhead by inserting four screws through the holes in the mounting bracket and into the mounting surface.
2. Connect all cables.
3. Secure the cables to the cable support using tie-wraps.

Make sure that the grounding requirements are met. See *Grounding and RF protection* on page 56.

Installing the terminal on a desktop

Four rubber feet make the terminal well suited for desktop installation. Simply place the terminal on a desktop and connect all cables.

If required, fasten the terminal to the desktop with four screws, as described in the previous section *Installing the terminal on a bulkhead*.

Make sure that the grounding requirements are met. See *Grounding and RF protection* on page 56.

Connecting power

Power source

There are different options for the power supply:

- The 24 V DC ship supply provides power for the terminal.
- A 12 V DC supply provides power for the terminal. Note that the maximum allowed source impedance is much lower for a 12 V DC supply than for a 24 V DC supply.
- A 230 V AC supply provides power through an AC/DC power supply.

Be aware of high start-up peak current: 20 A at 24 V, 5 ms.

The terminal is equipped with an internal 20 A Fuse, so no external fuse is necessary in order to protect the terminal. However, in order to avoid short circuit in the power cable/connector, the ship's DC outlet should be protected by a 30 A fuse or circuit breaker.

Power cable selection

Source impedance

The length of the power cable depends on the type of cable used and the source impedance of the DC power installation in the ship.

The maximum allowed source impedance depends on the utilization of the power range of the terminal DC input (10.5 - 32 V DC; 14 - 5.5 A).

Select a power outlet from the DC system and measure the source impedance of the ship installation as described in *Measuring the ship source impedance* on page 55 in Appendix B.

Note

If the total impedance is higher than the limits stated in this section, the terminal may become unstable and start to on/off oscillate.

The total impedance is made up of the source impedance of the ship power supply plus the impedance of connected cables including connectors and joints where cables are extended.

For further recommendations on power cable selection, see the next section.

Power cable recommendations

Overview

The terminal is delivered with a power cable, which can be extended according to the recommendations in this section.

- When extending the power cable, positive and negative supply wires must be installed closely together side by side to keep cable inductance low.
- Ensure that cable inductance for the selected cable at the desired length is below the 50 μ H requirement.

The power cable contains the following wires:

Color of wire in power cable	Pin number in connector	Function
Red	A1	Vin+
Black	A2	Vin-
(Black)	1	not connected
Green	2	Remote on/off
(Brown)	3	not connected
(Red)	4	not connected
Orange	5	Remote on/off

Calculating the maximum power cable extension

For 24 V DC operation, the total impedance must be max. 500 mΩ, including the source impedance in the ship installation.

For 12 V DC operation, the total impedance must be max. 85 mΩ, including the source impedance in the ship installation.

The total impedance is made up of the following:

- the source impedance in the ship installation
- the cable impedance of the supplied power cable, including the impedance in the joint of the two cables. In the following example, the impedance of the cable and joint is set to 10 mΩ (1 m power cable). Note that if the cable length or type is changed, the impedance will change accordingly.
- the extension cable impedance.

To calculate the maximum cable extension, do as follows:

1. First measure the source impedance in the ship installation as shown in *Measuring the ship source impedance* on page 55.
2. Then find the resistance per meter for the cable type you are going to use.
For 4 mm²/AWG 11, the value is 4 mΩ/m at 20°C
For 1.5 mm²/AWG 15, the value is 10 mΩ/m at 20°C
For other cable types, refer to the data sheet for the cable.
3. Calculate the maximum allowed impedance in the extension cable as follows:
Max. allowed impedance in extension cable = max. total impedance - (measured source impedance + impedance of the supplied cable).
4. Then calculate the max. extension cable length as follows:

$$\text{Max. length} = 0.5 \times \frac{\text{Max. impedance in extension cable (from step 3.)}}{\text{impedance/meter (from step 2.)}}$$

The length is multiplied by 0.5 above because there are two conductors in the cable.

Example:

Ship supply voltage: 12 V DC

Ship source impedance (measured): 50 mΩ

Extension cable type: 4 mm² (AWG 11)

$$\text{Max. cable extension} = 0.5 \times \frac{85\text{m}\Omega - (50\Omega + 10\text{m}\Omega)}{4\text{m}\Omega / \text{m}} = 3.12\text{m}$$

In this case, the power cable can be extended with up to 3.12 m.

If you need more length, you can double the maximum allowed length by connecting two cables instead of one, or you can use a cable with a larger diameter.

Connecting power

Connecting the power cable

To connect the power cable

Do as follows to connect the power cable:

1. Connect the red (+) and black (-) wires of the power cable to the ship's 24 VDC supply according to the recommendations in the previous sections.
2. Connect the D-sub connector on the power cable to the DC input connector on the terminal.

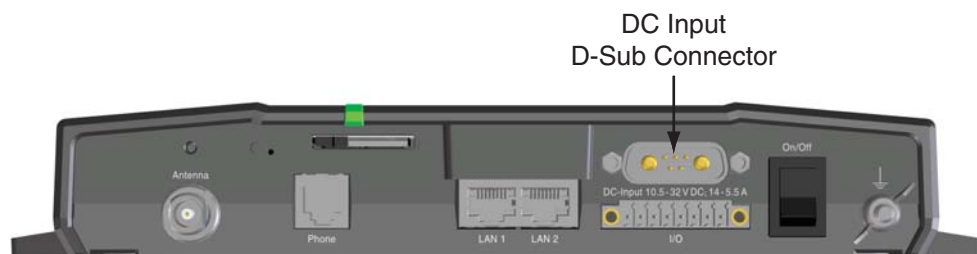

If you need a **remote on/off** function, you may use one of the following options:

- Connect the Remote on/off wires in the power cable to a remote switch.
- Connect the ignition pins in the I/O connector to the ignition of your vessel.
For further information, see *Connecting to the ignition* on page 22.

For information on pin-out, see *DC power input* on page 26.

For specifications of the DC input on the terminal, see *General specifications* on page 51.

Connecting to the ignition

The terminal has an ignition function. When this function is used, the terminal switches on/off when you start/stop the engine of your vessel (provided the power switch on the terminal is on).

Use the web interface to configure the ignition function according to your needs. In the web interface, select **SETTINGS > Discrete I/O**. Select if the Ignition pin should be "Active high" or "Active low" and set up a delay determining how long the terminal will stay on after switching the ignition off. For further information on the web interface, see the user manual for the TracPhone system.

To implement the ignition function, connect the appropriate pin in the I/O connector to the ignition key switch:

- Active high (default): Connect pin 5 to Ground. Connect pin 8 to “high” (10.5-32 V DC when the ignition is on).
- Active low: Connect pin 8 to positive DC voltage (10.5-32 V DC). Connect pin 5 to Ground (< 1.2 V DC when the ignition is on).

Pin-out and default functions: See *Discrete I/O interface* on page 31.

Standby current when the ignition power is off: See *Standby current* on page 52.

Connecting a remote on/off switch

The terminal has a remote on/off function. When the terminal power switch is in the “on” position you can remote-control the power function.

By installing a switch that can short-circuit the “Remote on/off” pins (2 and 5) in the power connector you can power the terminal on or off with this remote switch.

When pins 2 and 5 are not short-circuited and valid input power is present, the terminal is powered on, provided the Power switch on the terminal is in the “on” position.

For pin-out of the power connector and a description of the wire colors in the power cable, see *Pin-out* on page 26.

For information on the standby current when the remote on/off switch is off, refer to *Standby current* on page 52 in the *General specifications*.

Hardware interfaces

The connector panel

The connector panel is placed at one end of the terminal and has the following connectors:

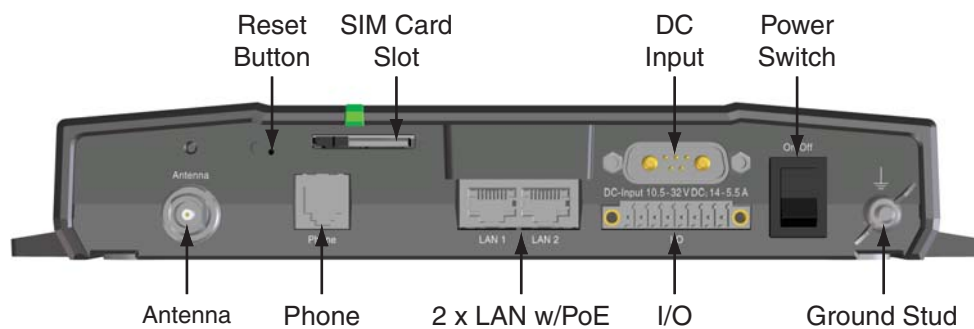

- 1 Antenna connector (TNC)
- 1 Phone connector
- 2 LAN connectors with Power over Ethernet (PoE)
- 1 DC power input connector for connection to 10.5-32 V DC, with optional remote on/off
- 1 Input/Output connector with 5 inputs/outputs for external control or signaling
- 1 ground stud with wing nut

For information on how to connect to a specific interface, see the next sections.

Antenna interface on terminal

Overview

The antenna interface on the terminal connects to the TracPhone FB150 antenna. The antenna connector on the terminal is a TNC female connector placed in the connector panel.

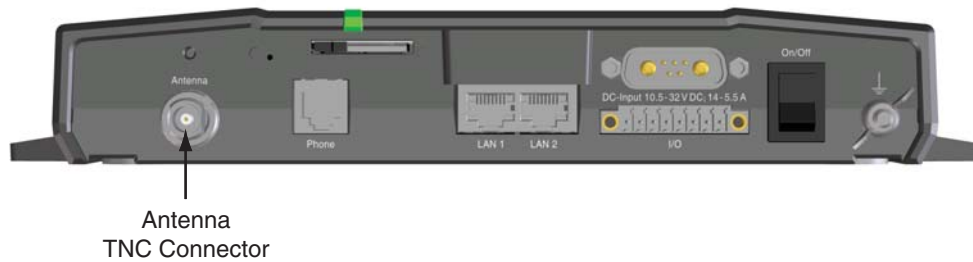

For information on cables and how to install and connect the antenna, see *Installing the antenna* on page 12.

Pin-out

The below drawing shows the TNC female connector in the terminal.

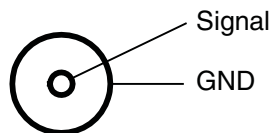

DC power input

Overview

The DC power input for the terminal is a 10.5 - 32 V DC; 14 - 5.5 A input with a remote on/off function. The input is protected against reverse polarity.

The power connector is a D-sub connector placed in the connector panel.



For information on power recommendations and how to connect, see *Connecting power* on page 19.

Pin-out

The power connector is a Mixed D-Sub connector 7W2, control pin male/ power pin male. The below table shows the pin-out for the connector and the colors of the corresponding wires.

Pin number	Pin function	Color of wire in power cable
A1	Vin+	Red
A2	Vin-	Black
1	not connected	(Black)
2	Remote on/off	Green
3	not connected	(Brown)
4	not connected	(Red)
5	Remote on/off	Orange

Mixed D-Sub connector, 7W2, male

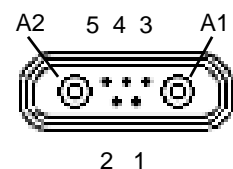

Ground stud

The terminal has a ground stud with a wing nut. The ground stud is located in the connector panel and is used for grounding the terminal.

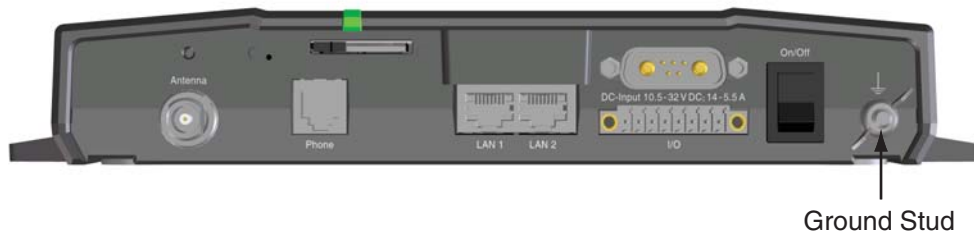

For information on how to ensure proper grounding of the terminal, see *Grounding the terminal* on page 16 and *Grounding and RF protection* on page 56.

Analog Phone interface

Overview

The terminal has one RJ-11 port, which can be used for connection of an analog phone.

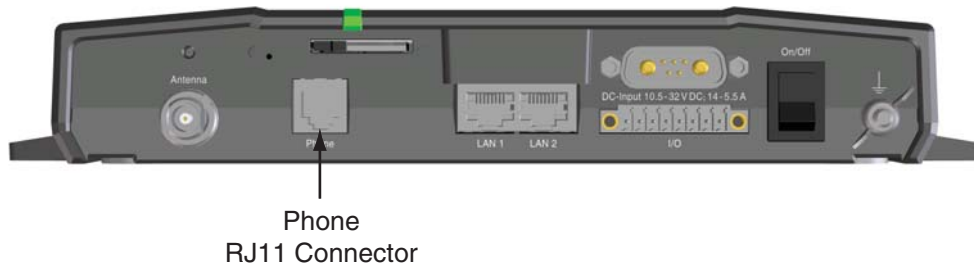

Pin-out

The Phone connector is an RJ-11, 6/4 female connector. The table and figure below show the connector outline and pin assignments.

Pin number	Pin function
1	-
2	not connected
3	Tip
4	Ring
5	not connected
6	-

RJ-11 female connector

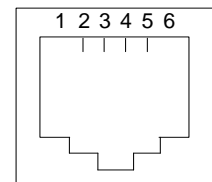

LAN interface

Overview

The terminal has two Ethernet LAN ports with Power over Ethernet (PoE). The Ethernet ports are standard IEEE 802.3 af ports using RJ-45 connectors.

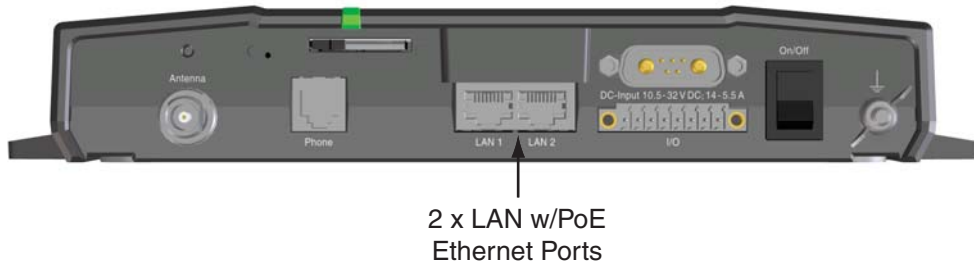

Power over Ethernet (PoE)

One power supply powers both interfaces with a floating 48 V DC supply (44 - 57 V DC). Therefore, the interfaces are not galvanically separated from each other. Both Tx signals are DC connected to the Positive PoE Voltage and both Rx signals to the Negative PoE Voltage.

- The total output power from the interfaces is 32 W.

Both interfaces can support devices of power class 1, 2 and 3 (4, 7 and 15.4 Watt), as long as the total power consumption does not exceed the above limits.

In case of power hold-up (failure on input power), PoE will be turned off.

Pin-out

The figure and table below show the connector outline and pin assignments.

Pin number	Pin function
1	TxD+ input (positive PoE)
2	TxD-input (positive PoE)
3	RxD+ output (negative PoE)
4	not connected
5	not connected
6	RxD- output (negative PoE)
7	not connected
8	not connected

RJ-45 female connector

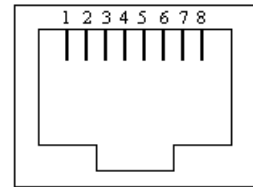

Connecting the IP handset

To connect the IP handset to the terminal, do as follows:

Connect the cable from the IP cradle to one of the LAN connectors on the terminal, preferably port 1. In case of insufficient power to the LAN PoE the LAN ports are prioritized, so that port 1 is the last to be closed down.

Note that the handset and terminal must be set up to be able to communicate with each other. For further information, refer to the user manual for the handset.

The maximum length of the cable between IP cradle and terminal is 80 m.

Note If you insert a switch or similar between the cradle and the terminal, make sure that it conforms to the industry standard **IEEE 802.3 af (using data pairs)**.

Discrete I/O interface

Overview

The terminal has an I/O connector with 5 configurable inputs/outputs.

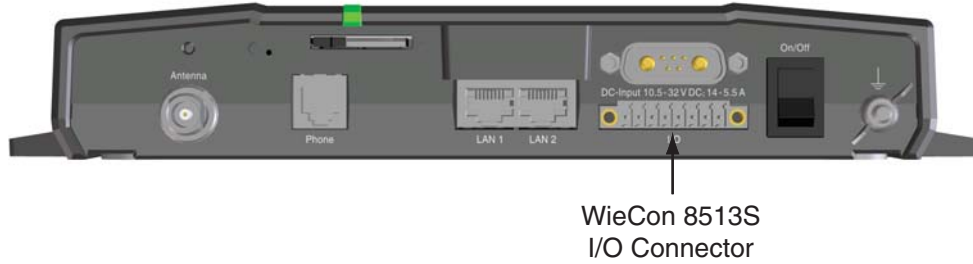

The connector is a WieCon Type 8513S connector. A mating I/O connector is included in the kit.

Pin-out

The figure and table below show the connector outline and pin assignments.

WieCon Type 8513S connector

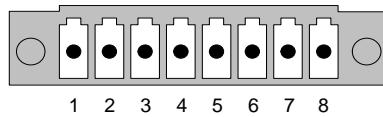

Pin number	Connection	Default configuration ^a
1	GPIO 1	Ringer output, active high
2	GPIO 2	Warning/Error output
3	GPIO 3	Mute output
4	GPIO 4	Radio silence input
5	GPIO 5	Ignition input
6	Chassis GND	Chassis GND
7	DC out	9-15 V DC, 50 mA
8	DC in	(ignition input)

a. Default functions of the I/O pins are described in the next section.

Default configuration of I/O pins

The built-in web interface of the terminal offers a page for configuring the I/O pins.

The default configuration of the I/O pins is as follows:

- **Pin 1: Ringer output.**
(Default setting: Normally open)
Pin 1 acts as a built-in switch in the terminal. By default, this pin is internally connected to Ground when the terminal is notified of an incoming call from the satellite interface. When the call is answered, or the caller gives up and releases the call, the pin is disconnected (open).
- **Pin 2: Warning/Error output.**
(Default setting: Normally open)
Pin 2 acts as a built-in switch in the terminal. By default, this pin is internally connected to Ground when there is an active warning/error condition in the terminal. The pin stays connected to ground until all warnings/errors are cleared.
- **Pin 3: Mute output.**
(Default setting: Normally open)
Pin 3 acts as a built-in switch in the terminal. By default, this pin is internally connected to Ground as long as there is a phone call in progress. This signal can be used to mute external equipment.
When the call is released, the pin is disconnected (open).
- **Pin 4: Radio silence input.**
(Default setting: Active Low)
By default, pin 4 is activated when externally connected to Ground. When pin 4 is activated, the terminal observes Radio Silence. The terminal gracefully closes all open connections, and deregisters from the BGAN network. No transmission is allowed until the pin is deactivated (disconnected from Ground).
- **Pin 5/8: Ignition input.**
(Default setting: Active high)
The ignition function can be used to turn on/off the terminal by means of an external signal. The ignition function uses pin 5 together with pin 8 (DC in).
Connect the appropriate pin to the ignition switch as follows:
Active high (default): Connect pin 5 to Ground. Connect pin 8 to "high" (10.5-32 V DC) when the ignition is on.
Active low: Connect pin 8 to positive DC voltage (10.5-32 V DC). Connect pin 5 to Ground (< 1.2 V DC) when the ignition is on.
- **Pin 6: Ground.**
(Non-configurable)
Pin 6 can be used as an external connection to ground. Pin 6 is connected to Ground in the terminal.
- **Pin 7: DC output.**
(Non-configurable)
Pin 7 can be used as a DC output. The voltage on pin 7 is 9-15 V and the output can supply up to 50 mA. Pin 7 can be used as power supply to a relay, ringer or similar.

For information on how to configure the I/O pins, see the user manual for the TracPhone FB150 system.

Starting up the system

Using the SIM card

Inserting the SIM card

The SIM card is provided by your Airtime Provider. Insert the SIM card as follows:

1. Open the SIM cover in the left side of the connector panel.



2. Insert the SIM card into the SIM slot. Place the card with the chip side facing up as shown.

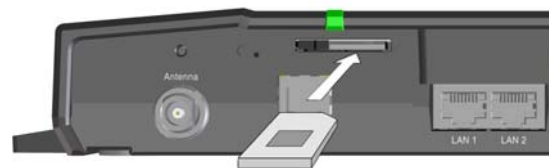

3. Press gently until it clicks.

4. Slide the lock in front of the SIM card.

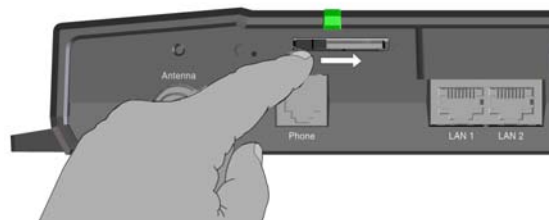

5. Close the cover for the SIM slot.

Removing the SIM card

Note

When the SIM card is removed, you cannot use the BGAN menu of the IP handset nor make calls or start data sessions.

Only emergency calls are allowed, and only if permitted by the network.

However, if you have an administrator user name and password, you can upload software using the web interface without having a SIM card. For further information, see the user manual for the TracPhone FB150 system.

Remove the SIM card as follows:

1. Open the SIM cover in the left side of the connector panel.



2. Slide the lock aside.



3. Gently push the SIM card and let it pop out.

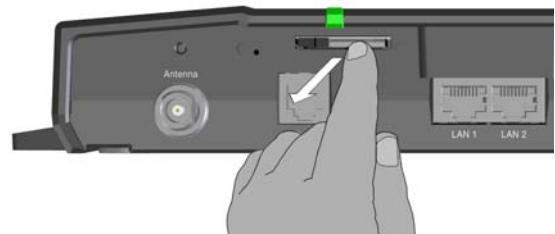

4. Remove the SIM card and close the cover for the SIM slot.

Powering the system

Switching the terminal on

Using the power switch

To **switch on** the terminal, use the On/Off switch in the connector panel. It normally takes one or two seconds for the terminal to switch on.



Using the ignition system

Normally the ignition function is not used in maritime installations. Instead you may want to use the remote on/off function described in the next section.

If you have connected the ignition system of your vessel to the I/O connector, you may leave the power switch in the “on” position and the terminal will switch on/off when you start/stop the engine of your vessel.

When the engine is stopped the terminal is in standby mode, meaning that only the primary parts of the system are kept alive. The standby current is max. 15 mA when the ignition is off. For information on how to connect to the ignition, refer to *Connecting to the ignition* on page 22.

You must set up the ignition function in the web interface. For further information, see the user manual for the TracPhone system.

Note In some cases, the system may reboot after power-on because of the high start-up current.

Using a remote on/off switch

If an external switch is connected to the remote on/off pins in the DC connector, you may leave the power switch in the connector panel in the “on” position and use the remote switch to turn the terminal on and off. When the remote switch is off, the terminal is off. However, if you leave the power switch on the terminal in the “on” position, you can always switch the terminal back on with the remote switch. The standby current when the remote switch is off is max. 2 mA. For further information on how to connect a remote on/off switch, see *Connecting a remote on/off switch* on page 23.

Switching the terminal off

To **switch off** the terminal, change the position of the power switch again.

Note | Wait at least 5 seconds after power off, before trying to power on the system again.

To **switch off using the Ignition function**, leave the On/Off switch in the connector panel in the On position and turn off the ignition.

Entering the SIM PIN for the terminal

Overview

If your SIM card requires a PIN, you have to enter a PIN to use the system. You can enter the PIN using a standard phone, the IP handset or the web interface.

For information on how to connect the handset or computer you are going to use, refer to the user manual.

Entering the PIN using a phone or IP handset

To enter the PIN

If you have a phone connected to the terminal, you can use it to enter the PIN at start up.

Do as follows:

- **For an analog phone:**
Pick up the phone. When the terminal is waiting for a PIN, you will hear 2 beeps - pause - 2 beeps - etc.
Dial <PIN> followed by #.
When you hear a "busy" tone or a dialing tone, the PIN has been accepted and you can hang up or dial a number.
- **For an IP handset:**
Select the **BGAN** menu, select **ENTER PIN** and enter the user name and password for the terminal. Then enter the PIN for the terminal.

Note | The ENTER PIN menu item is only available if your SIM card requires a PIN, and the PIN has not yet been entered and accepted in the terminal.

Wrong PIN

Analog phone:

If, instead of the busy tone or dialing tone, you continue to hear 2 beeps - pause - 2 beeps - etc., it means the PIN was not accepted. Check that you have the correct PIN and try again.

If a wrong PIN has been entered three times, you will hear 3 beeps - pause - 3 beeps - etc. This means you have to enter the PUK (PIN Unblocking Key) provided with your SIM card.

After entering the PUK, you must enter a new PIN of your own choice (4 to 8 digits long).

Dial the following:

<PUK> * <New PIN> * <New PIN> followed by # or off-hook key.

Example: If the PUK is 87654321 and the new PIN is 1234, dial
87654321 * 1234 * 1234 followed by # or off-hook key.

If you enter 10 wrong PUKs, the SIM card will no longer be functional. Contact your Airtime Provider for a new SIM card.

IP handset:

After having entered the user name and password for the terminal you have 3 attempts to enter the terminal PIN, before you are asked to enter the PUK (Pin Unblocking Key). The PUK is supplied with your terminal SIM card.

Enter the PUK followed by a new PIN of your own choice. The PIN must be from 4 to 8 digits long.

If you enter a wrong PUK 10 times, the SIM card will no longer be functional, and you have to contact your BGAN Airtime Provider for a new SIM card.

Entering the PIN using the web interface

If your SIM card requires a PIN and the PIN has not yet been entered when you start up the web interface, the start-up page will be the PIN page. Enter the PIN and click **OK**.

For further information on web interface, see the user manual.

Operating the system

General use

The user manual for the TracPhone system describes general use of the system and goes through all the functions of the web interface. It also contains a brief description of how to use the IP handset with the terminal.

User interfaces

Overview

The main user interfaces for operation of the system are

- the built-in web interface using a connected computer with an Internet browser
- the IP handset

Built-in web interface

The built-in web interface is used for easy configuration and daily use. You access the web interface from a computer connected to the terminal, using an Internet browser. No installation of software is needed.

An Administrator password is required to access advanced configuration of the system. From factory, the Administrator User name is **admin** and the Administrator password is **1234**.

For further information on the web interface, refer to the user manual for the TracPhone system.

IP handset

Apart from the standard functions of an IP handset, the IP handset contains a display menu for the TracPhone system. For further information on the IP handset, refer to the user manual for the IP handset.

Troubleshooting

Reset button

How to access the Reset button

The terminal has a Reset button placed next to the SIM slot behind the SIM cover. The functions of this button is described in the next section.



To press the Reset button, use a pointed device.

Functions of the Reset button

The Reset button on the terminal has the following functions:

Action	Function
With the terminal running, press the Reset button normally.	<p>The terminal IP address and IP netmask are temporarily set to the default value (default IP address: 192.168.0.1).</p> <p>With this function, even if the IP address changed and you do not remember the new IP address, you can still access the web interface and see your current configuration. The default value is not saved in the configuration, but is only valid until next reboot.</p>
With the terminal running, press and hold the Reset button for 30 seconds, until the Power indicator on the terminal is flashing orange.	The terminal restores factory settings and reboots the system.
While the terminal is booting, press and hold the Reset button.	<p>For service use only!</p> <p>The bootloader initiates software upload. This firmware upload procedure is only to be used if the other procedures fail due to missing or corrupted firmware. This setup uploads software to the terminal from a TFTP server via the LAN connection. The procedure is as follows:</p> <ol style="list-style-type: none"> 1. Activate or install a TFTP server on a PC. 2. Locate the correct software image (xxx.dl) for the terminal and place it in the TFTP server directory. 3. Rename the image to ttexp.dl. 4. Reconfigure the PC LAN interface to use the static address 192.168.0.2/255.255.255.0. 5. Power off the terminal. 6. Connect the PC LAN Interface to the terminal. 7. Press and hold down the Reset button. 8. Keep the Reset button pressed while powering on the terminal, and through the next step. 9. Monitor the TFTP server window. When the upload starts you can release the Reset button. <p>When the TFTP upload finishes the terminal boots up using the new image.</p>

Status signaling

Overview

The TracPhone system uses event messages and a light indicator for Power to display the status of the system.

Power indicator

The Power indicator is placed above the SIM slot in the connector panel.

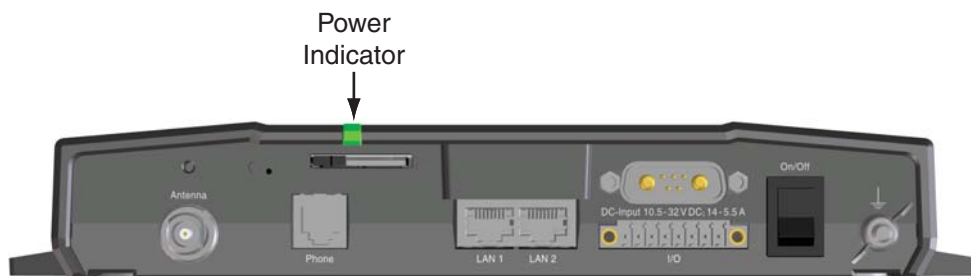

The Power indicator has the following functions:

Behavior	Meaning
Steady green	Power OK.
Flashing green	The terminal is powering up.
Flashing orange	The terminal is shutting down.
Off	No power.

Event messages

Display of event messages

The terminal can detect events during

- **POST** (Power On Self Test)
- a self test performed at every power-up,
- **PAST** (Person Activated Self Test)
- a self test performed when you click the **Self test** button under **Help desk** in the web interface, or
- **CM** (Continuous Monitoring)
- continuous monitoring while the system is in operation.

When the terminal detects an event that requires your action, it issues an event message.

You can see the active event messages in the web interface by clicking the warning symbol in the icon bar at the top in the web interface.

All events are logged in the event log. For information on the event log, see *Event log* on page 43.

Logging of events

Diagnostic report

When contacting KVH Industries for support, please include a diagnostic report. The diagnostic report contains information relevant for troubleshooting.

To generate the diagnostic report, access the web interface and select **Help Desk**. Then click **Generate report**.

Event log

The event log holds information of all registered events in the terminal or antenna.

The log includes the time of the occurrence, a short description, location of the error etc. This information can help troubleshooting errors in the system. You can see the event log in the web interface. For further information on the web interface, see the user manual for the TracPhone FB150 system.

Part numbers

System units

***TracPhone FB150 system with 10.8" (27.6 cm) dome
(part number 34-403744A)***

Item	Part number
Antenna	34-403050C
Terminal	34-403739A

***TracPhone FB150 system with 13.5" (34.3 cm) dome
(part number 01-0320)***

Item	Part number
Antenna	02-1747
Terminal	34-403739A

***TT-3670A IP handset & cradle, wired
(part number 34-3670A)***

Item	Part number
IP handset, wired	34-403672A
IP handset cradle, wired	34-403674A

Spare parts

For information on available spare parts, contact KVH Technical Support:

North/South America, Australia:
Phone: +1 401 847-3327
E-mail: techs@kvh.com
(Mon.-Fri., 9 am-6 pm ET, -5 GMT)
(Sat., 9 am-2 pm ET, -5 GMT)

Europe, Middle East, Asia:
Phone: +45 45 160 180
E-mail: support@kvh.dk
(Mon.-Fri., 8 am-4:30 pm, +1 GMT)

Technical specifications

Overview

This chapter contains specifications for the TracPhone FB150 system including the terminal and antenna.

Note For specifications and outline drawings for the IP handset, refer to the manual for the IP handset.

TracPhone FB150 antenna

General specifications

Item	Specification
Rx Freq. Band TX Freq. Band	1525.0 - 1559.0 MHz 1626.5 - 1660.5 MHz
Channel spacing	1.25 kHz
Antenna element gain Rx	11.0 dB min.
G/T	≥ -15.5 dB/K
EIRP	Min. EIRP: 3.1 dBW Max. EIRP: 16.1 dBW
Return loss	< -15 dB (reflection loss < 0.15 dB)
Cable losses	RF attenuation: max. 20 dB DC resistance (loop): max. 1 Ω Max. cable length between terminal and antenna: <ul style="list-style-type: none"> • RG223-D: 25 meters • RG214/U: 50 meters • S 07272B-05: 95 meters

Item	Specification
Antenna input voltage	22.7 V
Antenna power, operational	Maximum 39 W
Total antenna weight	10.8" (27.6 cm) dome: 8.7 lbs (3.94 kg) 13.5" (34.3 cm) dome: 11.5 lbs (5.2 kg)

Environmental specifications

Item	Specification
Water and dust	IPX6 spray proof in all directions, no dust test.
Ambient Temperature	Operational: -25° to +55°C Storage: -40° to +85°C
Operating humidity	100%, condensing
Ice, survival	Up to 25 mm of ice
Wind load, max.	Normal operation with relative average wind velocity up to 200 km/h (56 m/s, 108 knots)
Vibration, operational	Random spectrum 1.05 g rms x 3 axes: 5 to 20 Hz: 0.02 g ² /Hz 20 to 150 Hz: -3 dB/octave Sine: 2 to 13.2 Hz: ± 1 mm 13.2 to 100 Hz: 7 m/s ² 2 h dwell at resonances
Vibration, non-operational	Random spectrum 1.7 g rms 2 h x 3 axes 6 h total): 5 to 20 Hz: 0.05 g ² /Hz 20 to 150 Hz: -3 dB/octave

Item	Specification
Vibration, life test	At least 1.7 g rms for 2 hours pr. axis. Spectrum: 5 to 20 Hz: 0.05 g ² /Hz, 20 to 150 Hz: -3 dB/octave
Shock	Half sine, 20 g/11 ms
Solar radiation	1120 W/m ² according to MIL-STD-810F 505.4
Air Pressure, operational	1500 m AMSL
Air Pressure, transport	4572 m AMSL MIL-SPEC 810E 500.4
Ship motions (MAX)	Roll: 30°, period 4 sec., 0.7 g tangential Pitch: 15°, period 3 sec., 0.6 g tangential Yaw: 10°, period 5 sec., 0.3 g tangential Surge: 0.5 g Sway: 0.5 g Heave: 0.7 g Turning rate: 36°/s; 12°/s ² Headway: 22 m/s (42 knots)

Antenna outline dimensions

10.8" (27.6 cm) Dome

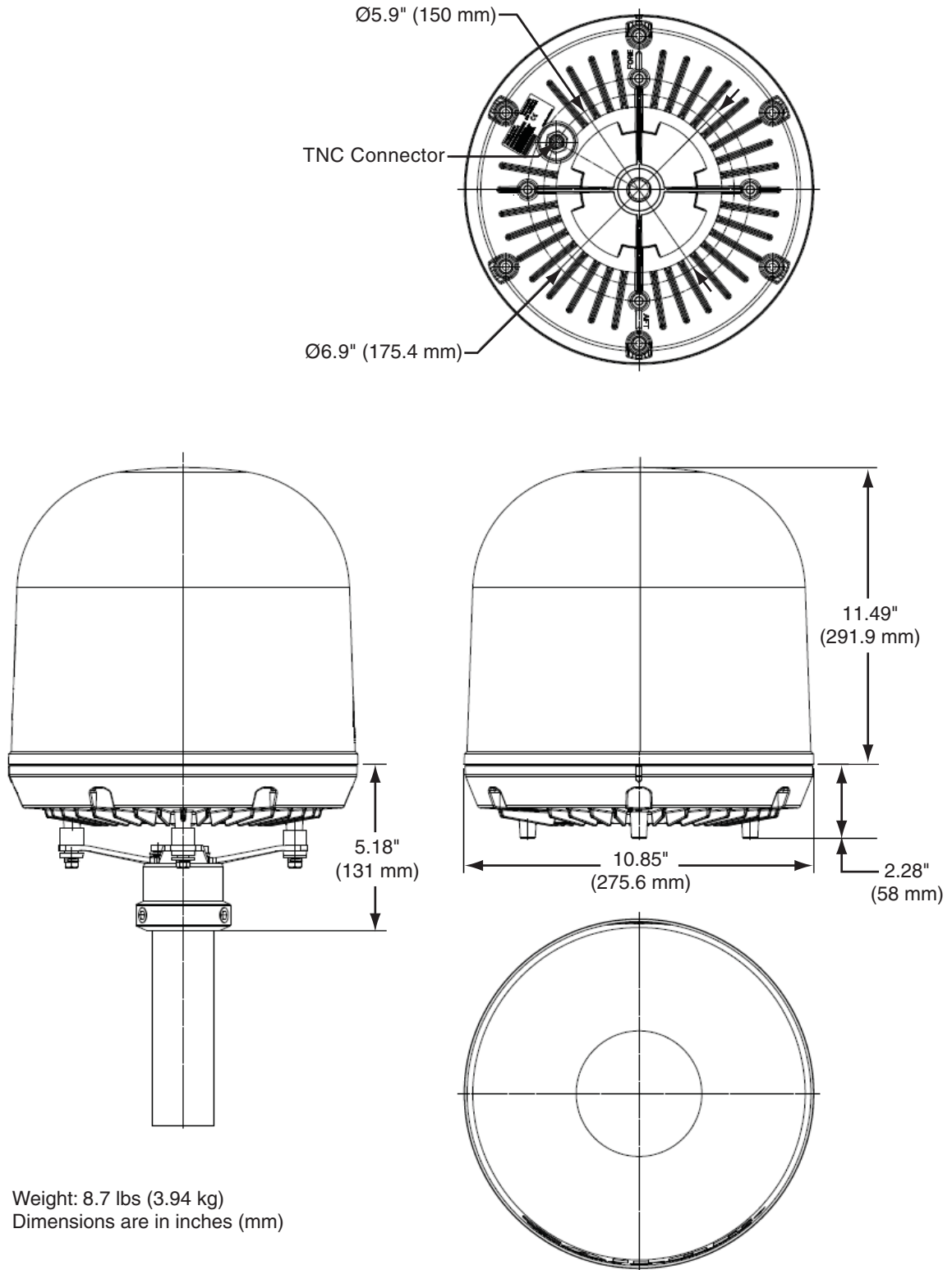

13.5" (34.3 cm) Dome

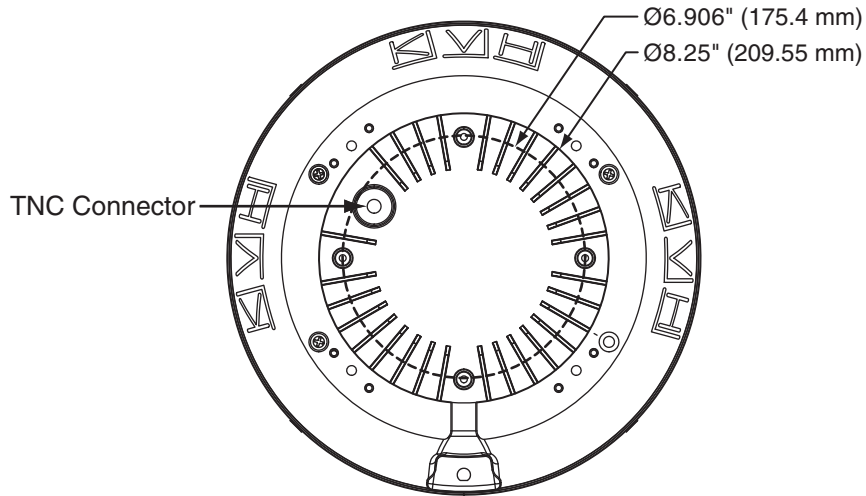

Weight: 11.5 lbs (5.2 kg)
Dimensions are in inches (mm)

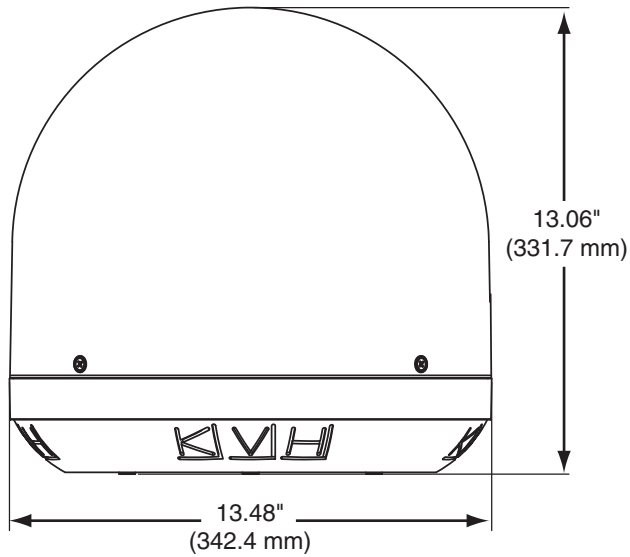

Minimum distance to transmitters

The table below shows the minimum recommended distance to transmitters in the frequency range below 1000 MHz.

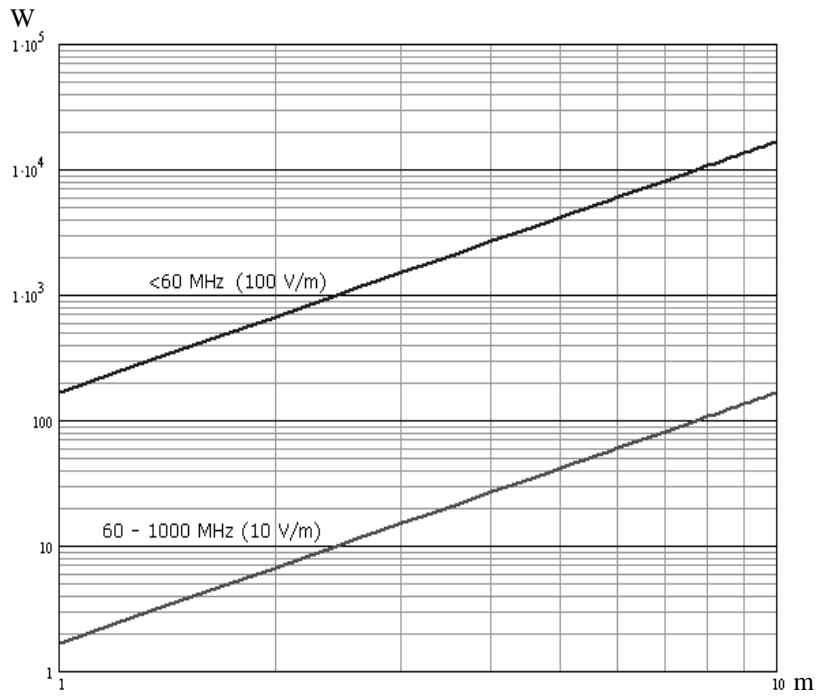

Recommended distance to TracPhone antenna.

TracPhone FB150 terminal

General specifications

Item	Specification
Weight	2.2 kg (4.9 lbs)
Dimensions	231 mm x 278 mm x 41 mm (9.1" x 10.9" x 1.6")
Global services	
Voice	4 kbps AMBE+2
Data	UP to 150 kbps Standard data
SMS	Up to 160 characters
Antenna interface	One connector, TNC-female 1525 to 1559 MHz: -94 dBm to -64 dBm 1626.5 to 1660.5 MHz: -9 dBm to +11 dBm Power supply: 18-29 V DC
2-wire telephone interface	One connector: RJ-11 female. 600 Ω ITU-T Rec. G. 473, standard DTMF telephone. Supported cable length: up to 100 meters.
LAN interface	Two connectors: RJ-45 female. Conforms with IEEE 802.3 af, 10/100 Mbps. Supported cable length: up to 100 m PoE (max. 15.4 W) on each port, Total PoE power: 32 W.

Item	Specification
<p>I/O interface</p> <p>Output:</p> <p>Open switch hold-off voltage</p> <p>Open circuit resistance</p> <p>Closed switch voltage</p> <p>Input:</p> <p>Input resistance</p> <p>Voltage</p> <p>Voltage High</p> <p>Voltage Low</p>	<p>One connector with 5 configurable inputs/outputs.</p> <p>Open collector, Short circuit protected at 1.5 A and reverse polarization protected.</p> <p>max. 32 V</p> <p>min. 130 KΩ</p> <p>max. 1 V DC at 50 mA</p> <p>min. 130 KΩ</p> <p>Max. 32 V</p> <p>Min. 2.2 V</p> <p>Max. 1.2 V</p>
<p>Power Input</p>	<p>Connector: Mixed D-Sub 7W2</p> <p>Nominal 12/24 VDC (10.5 - 32 V DC; 14 A - 5.5 A)</p> <p>Max. source impedance: 85 mΩ at 12 V, 500 mΩ at 24 V</p> <p>Maximum 20 A at 24 V, 5 ms (start up)</p> <p>Maximum power consumption: 75 W</p>
<p>Power consumption</p> <p>Idle, no waves</p> <p>Idle, w. waves</p> <p>FTP transfer, w. waves</p>	<p>Measured with wave simulator</p> <p>No peripherals connected: 15,67 W</p> <p>IP handset, phone and PC connected: 16,82 W</p> <p>Phone connected: 18,75 W</p> <p>IP handset, phone and PC connected: 20,2 W</p> <p>Download Standard (background) data: 21,4 W</p> <p>Upload Standard data: 31,09 W</p>
<p>Standby current</p>	<p>Ignition function, off: max. 15 mA</p> <p>Remote on/off in DC connector, off: max. 2 mA</p>
<p>Ambient temperature</p>	<p>Operational: -25° to +55°C</p> <p>Storage: -40° to +80°C</p>
<p>Relative Humidity</p>	<p>95% non-condensing at +40°C</p>
<p>Equipment category</p>	<p>Protected from the weather - IEC-60945</p>

Outline dimensions, TracPhone FB150 terminal

Connector panel, top view and end view.

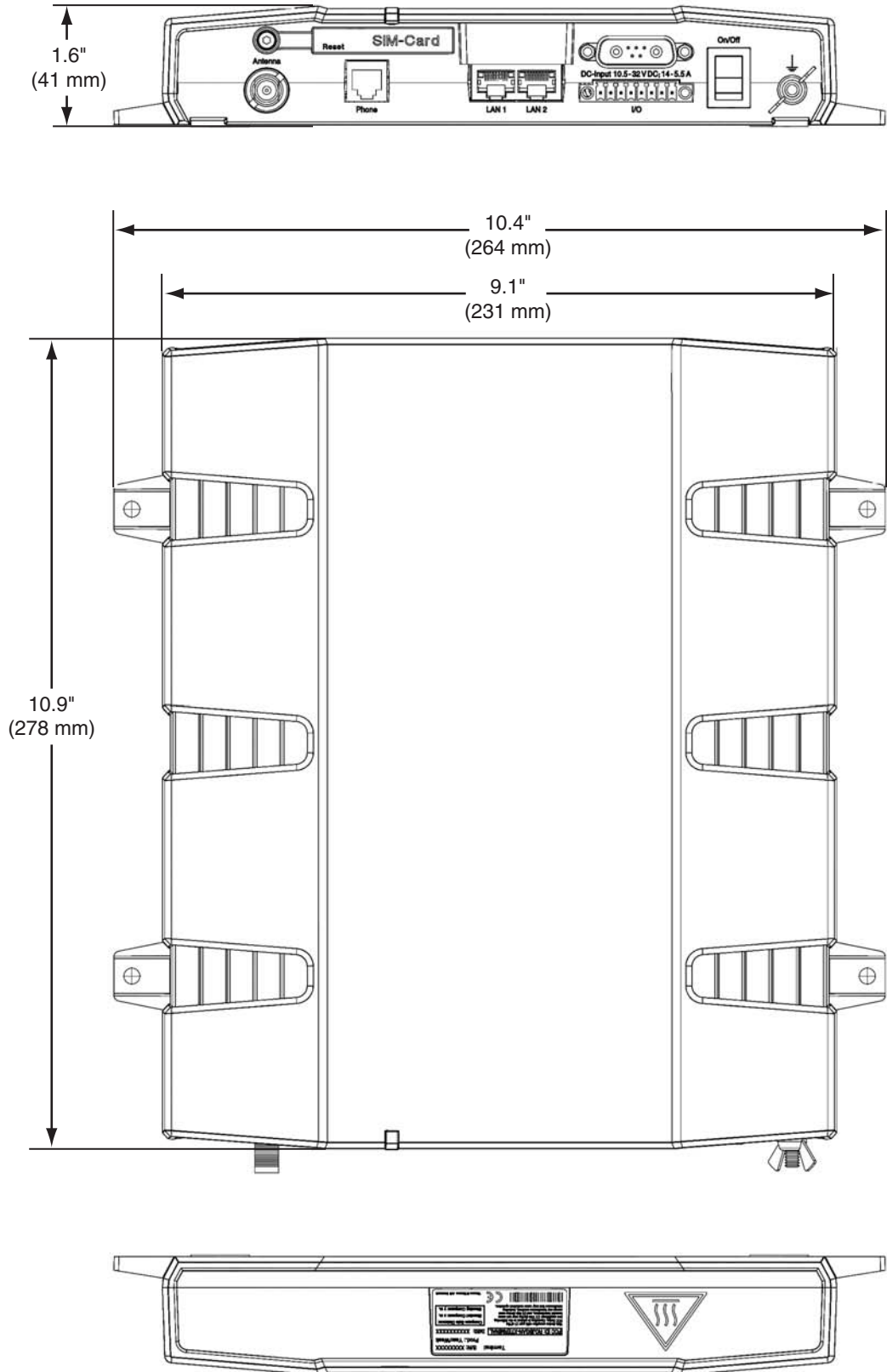

Side view and bottom view.

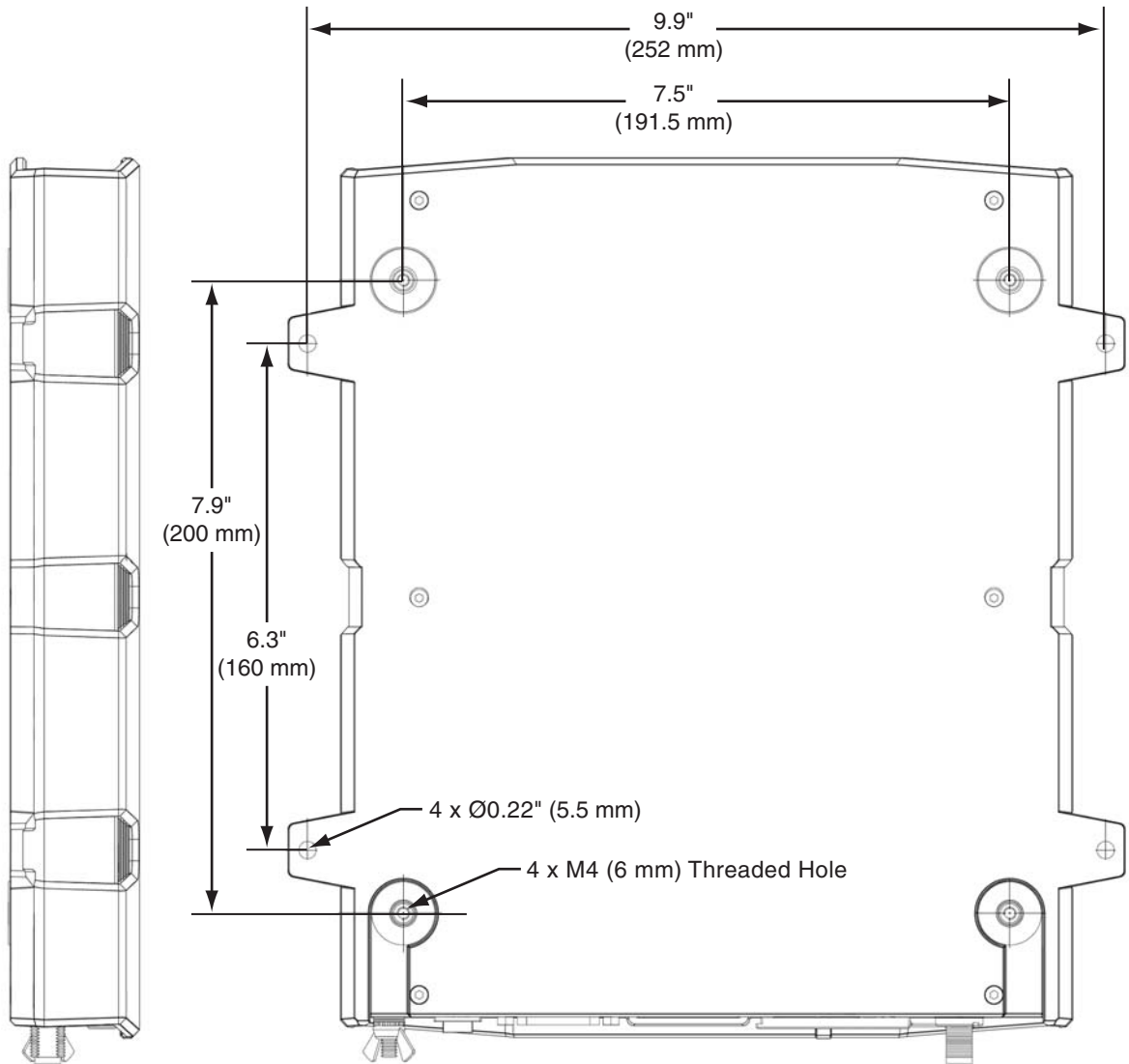

Weight: 4.8 lbs (2.2 kg)
Dimensions are in inches (mm)

Measuring the ship source impedance

Select a power outlet from the ship 24 V DC or 12 V DC system, and measure the source impedance of the ship installation as described below.

1. Measure the voltage without load (R.var disconnected).
2. Set the current to e.g. 1 A by adjusting R.var.
3. Measure the corresponding voltage change.

Example: 1 A and 50 mV. Source impedance: $50 \text{ mV} / 1 \text{ Amp} = 50 \text{ m}\Omega$.

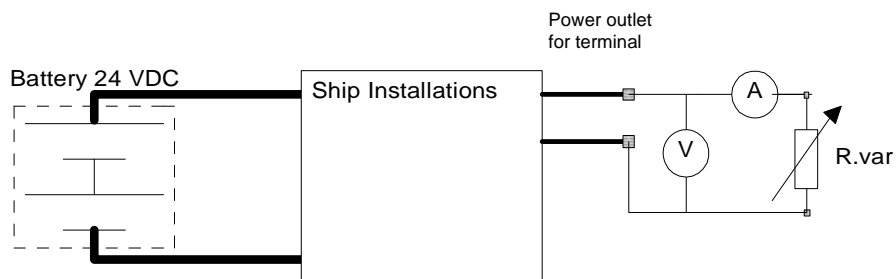

Grounding and RF protection

Why is grounding required?

Reasons for grounding

Grounding the TracPhone system is required for two reasons:

- Safety: Lightning protection of persons and equipment.
- Protection: ESD (ElectroStatic Discharge) protection of equipment.

Safety

First of all grounding of the system is required for safety reasons. In the event of a lightning strike at the antenna a proper grounding of the system will provide a low resistance path to divert the strike discharge to seawater.

ESD Protection

The ESD protection circuits in the terminal rely on proper grounding of the system in order to work properly. Otherwise sensitive circuits within the terminal might be damaged due to ESD when you are handling the equipment.

About marine DC systems

Wiring systems

Two basic wiring topologies are used for marine DC system grounding: **Two-Wire Return System** and **One Pole Grounded Return System**.

Two-wire Return System

This configuration implies that no part of the circuit, in particular the battery negative, is connected to any ground potential or equipment. The system is totally isolated and includes engine sensors, starter motors etc. This arrangement is preferred for steel and aluminum vessels.

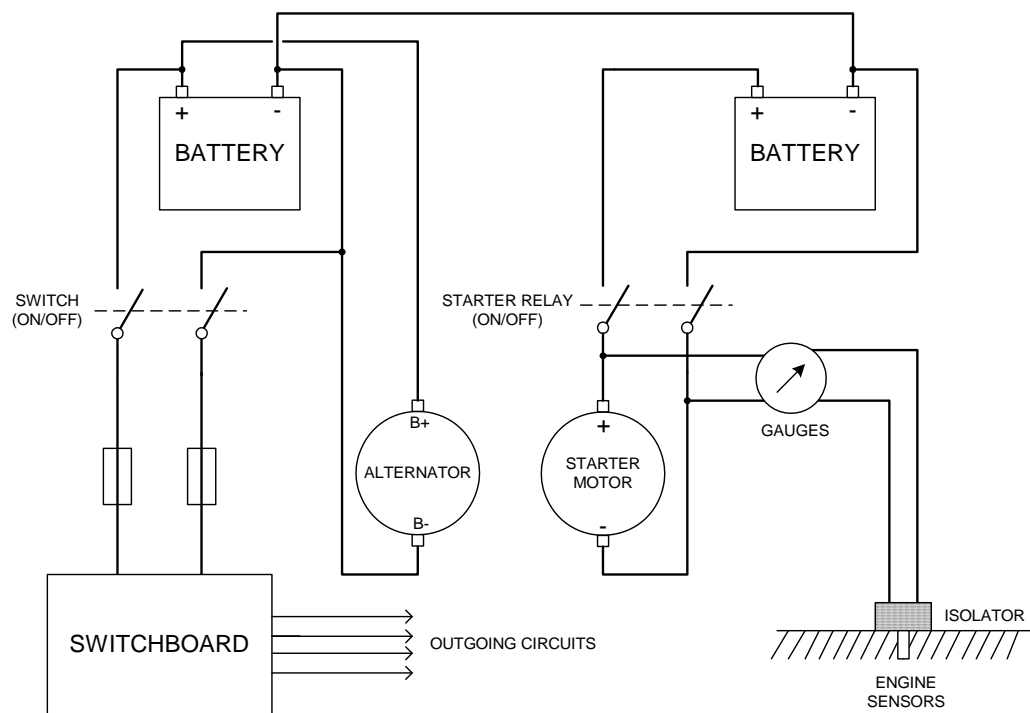

One Pole Grounded Return System

This configuration implies that the battery negative is bonded to a ground potential, typically at the engine negative terminal. This is done in order to polarize the DC electrical system.

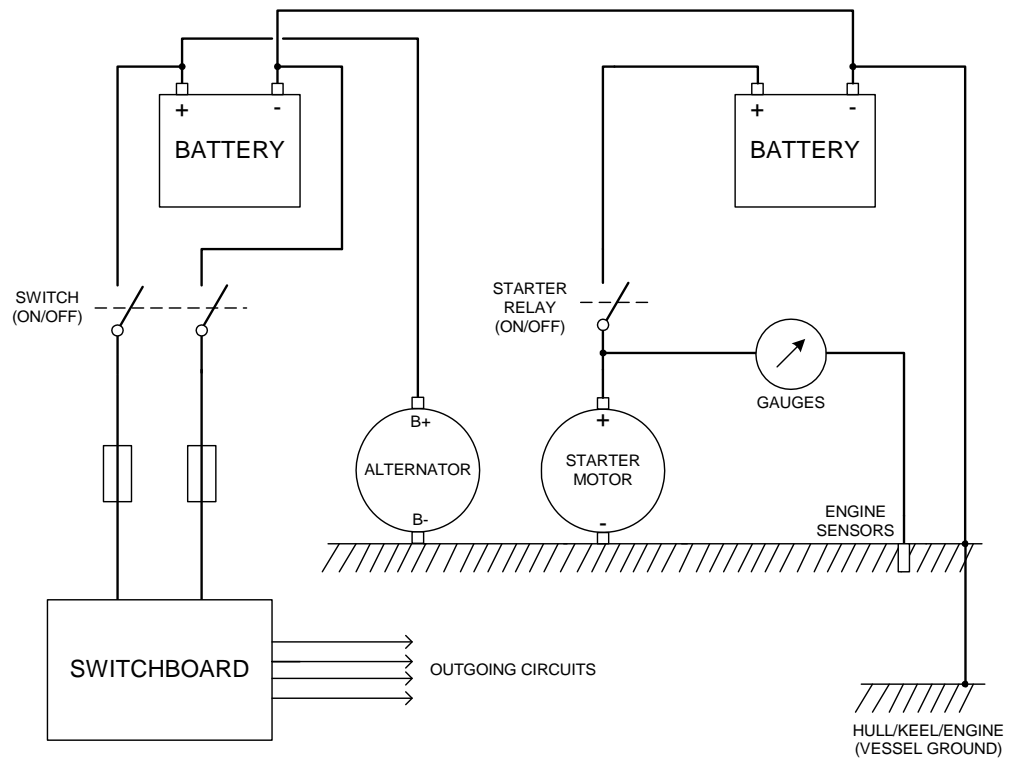

Note This arrangement is not suitable for steel and aluminum vessels as this might cause electrolytic corrosion of the hull.

About marine grounding

There is great confusion about the different ground terms used when dealing with marine electrical installations. The various terms are listed below for reference.

Term	Definition
DC Negative	Actually not a ground but a current-carrying conductor which carries the same current that flows in the positive conductor. The DC Negative may be electrically connected to seawater (at one point only, via the engine negative terminal though the shaft and the propeller) or left completely floating.
Lightning Ground	Ground potential immersed in seawater. Provides a path to ground lightning strike energy. Please note that this is not a functional part of any other electrical system.
Corrosion System Ground	Bonding arrangement that ensures equal electrical potential for all dissimilar underwater metal parts and provides galvanic protection by means of sacrificial anodes.
AC Ground (Protective Earth)	Ground potential immersed in seawater (typically the hull for steel and aluminum vessels). Serves as safety ground (protective earth) thus preventing shocks or electrocution in the event of a fault situation.
RF Ground (Capacitive)	Underwater ground potential that is capacitively coupled to seawater ground. Typically numerous pieces of bonded underwater metal parts such as keel (isolated), water tank, engine block etc. will act as a capacitive RF ground (that is; no DC connection to seawater). Often referred to as "counterpoise" for the SSB/HF aerial system.
RF Ground (Electrical)	Underwater ground potential that is electrically coupled to seawater ground by means of a separate ground plate (e.g. Dynaplate). Also referred to as "counterpoise" for the SSB/HF aerial system.

Grounding Recommendations

Grounding the terminal

The terminal should be grounded to the ship/hull by means of a short antenna cable and the grounding kit (accessory). Further, the terminal must be grounded at its grounding stud in order to ensure proper grounding if the short antenna cable is disconnected. For further information, see *Grounding the terminal* on page 16.

Grounding the antenna

You can ground the antenna to the ship/hull via one or more of its mounting bolts. Make sure to remove painting, dirt, grease etc. at the mounting holes in order to make good electrical contact to the hull. Use serrated washers when securing the mounting bolts and seal the joint with protective coating to avoid corrosion.

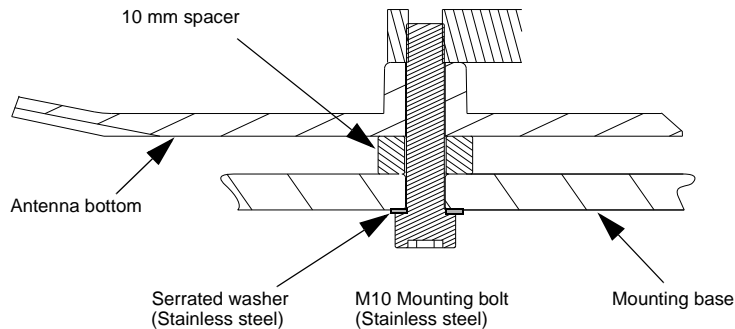

If you are using vibration isolators at the bolts, the grounding connection between the mounting surface and the bolts is not sufficient. In that case mount a separate grounding wire. See *Separate ground cable* on page 66.

It is always recommended to establish the shortest grounding path as possible e.g. on steel hulls the antenna should be grounded directly to the hull¹. However, due to the fact that this is not possible on e.g. fiberglass hulls (nor is it preferable on aluminum hulls) a number of alternative grounding methods are suggested in the following paragraphs.

1. Please note that the antenna ground connection is made at the same electrical ground potential as the terminal.

Alternative grounding for steel hulls

The following guidelines assume a two-wire, isolated grounding arrangement; that is no part of the circuit, in particular the battery negative, is connected to any ground potential or equipment.

Grounding the terminal

The terminal must be grounded to the ship with the short antenna cable and the grounding kit (accessory). Further, the terminal must be grounded at its grounding stud in order to ensure a proper grounding if the short antenna cable is disconnected.

The ground connection can be established either at the hull (recommended) or at a dedicated RF ground if available (alternative). However, bear in mind that the antenna ground connection is to be made at the **same electrical ground potential as the terminal** (see *Grounding the antenna*).

The terminal provides galvanic isolation (as required) from its input power terminals to the chassis/grounding stud. This way the isolated grounding arrangement is maintained.

Grounding the antenna

Terminal grounded at the hull (recommended)

In this case the antenna is grounded to the ship via one (or more) of its mounting bolts. Make sure to remove painting, dirt, grease etc. at the mounting holes in order to make good electrical contact to the hull. Use serrated washers when securing the mounting bolts and seal the joint with protective coating to avoid corrosion.

Terminal grounded at a dedicated RF ground (alternative)

In this case the antenna is grounded with a separate ground cable. The ground cable must be routed parallel and close to the shielded coax cable connecting the antenna to the terminal grounding kit. A tinned heavy gauge wire (min. 6 mm²) can be used for this purpose - see page 65.

Note

The antenna must be electrically isolated at its mounting bolts by means of shoulder bushings and washers ensuring the isolated RF ground - see page 68.

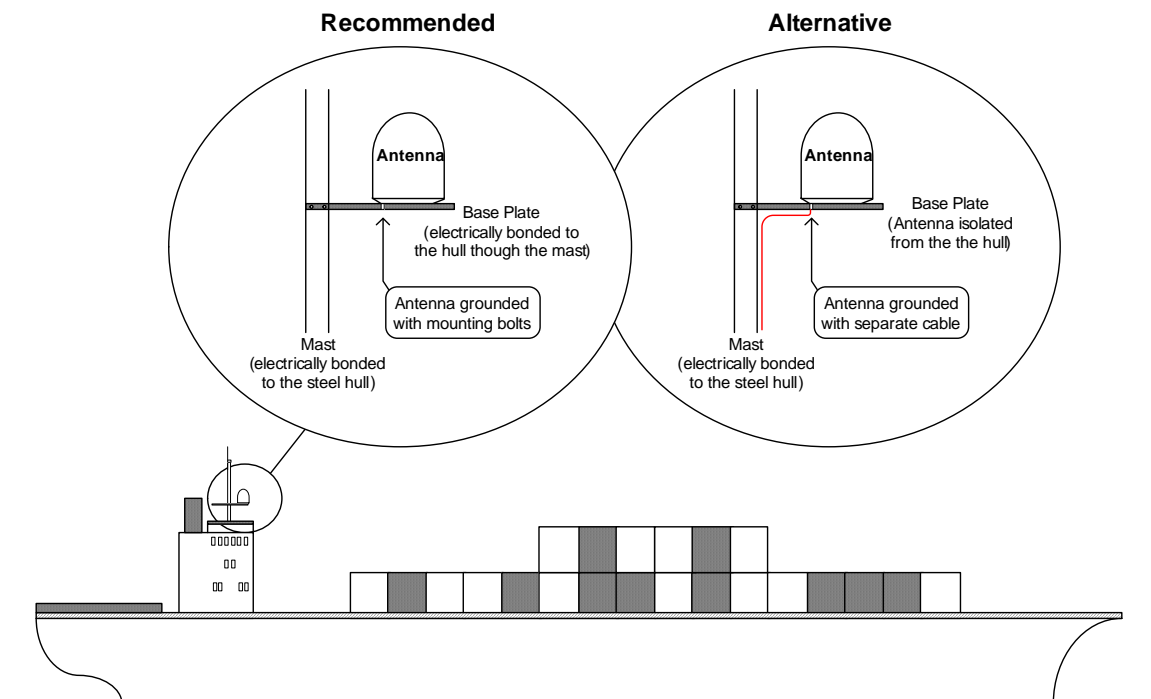

Alternative grounding for aluminum hulls

The following guidelines assume a two-wire, isolated grounding arrangement; that is no part of the circuit, in particular the battery negative, is connected to any ground potential or equipment.

Grounding the terminal

The terminal must be grounded with the short antenna cable and the grounding kit (accessory). Further, the terminal must be grounded at its grounding stud to ensure a proper grounding if the short antenna cable is disconnected.

The ground connection must be established at a dedicated RF ground (either capacitively or electrically coupled). Remember to make the antenna ground connection at the **same electrical ground potential** as the terminal (see *Grounding the antenna*). The terminal provides galvanic isolation (as required) from its input power terminals to the chassis/grounding stud. This way the isolated grounding arrangement is maintained.

Grounding the antenna

If the mounting base of the antenna is electrically connected to the hull (or any other ground potential than the terminal), the antenna must be isolated at its mounting bolts by means of shoulder bushings and washers - see page 68. This is done in order to prevent DC currents flowing in the hull thus causing electrolytic corrosion.

However, a ground connection must be established via one of the mounting bolts using a separate ground cable. The ground cable must be routed parallel and in close proximity to the shielded coax cable hence connecting the antenna to the terminal grounding kit. A tinned heavy gauge wire (min. 6 mm²) can be used for this purpose - see page 63.

Alternative grounding for aluminum hulls

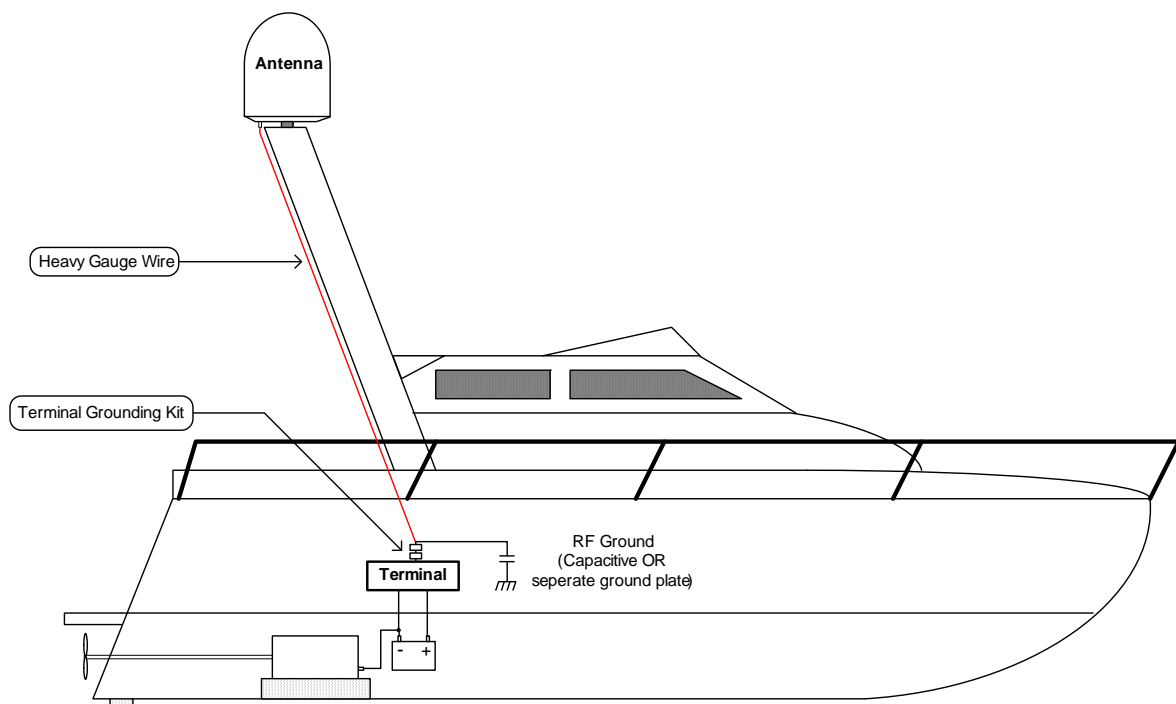

Alternative grounding for fiberglass hulls

Grounding the terminal

The terminal must be grounded with the short antenna cable and the grounding kit (accessory). Further, the terminal must be grounded at its grounding stud in order to ensure a proper grounding if the short antenna cable is disconnected.

The ground connection must be established at a dedicated RF ground (either capacitive or electrical coupled). Bear in mind that the antenna ground connection is to be made at the **same electrical ground potential** as the terminal (see *Grounding the antenna*).

Grounding the antenna

If the mounting base of the antenna is electrically connected to any other ground potential than the terminal (e.g. Lightning Ground), the antenna must be isolated at its mounting bolts by means of shoulder bushings and washers - see page 68.

However, a ground connection must be established via one of the mounting bolts using a separate ground cable. The ground cable must be routed parallel and in close proximity to the shielded coax cable hence connecting the antenna to the terminal grounding kit. A tinned heavy gauge wire (min. 6 mm²) can be used for this purpose - see page 64.

Alternative grounding for fiberglass hulls

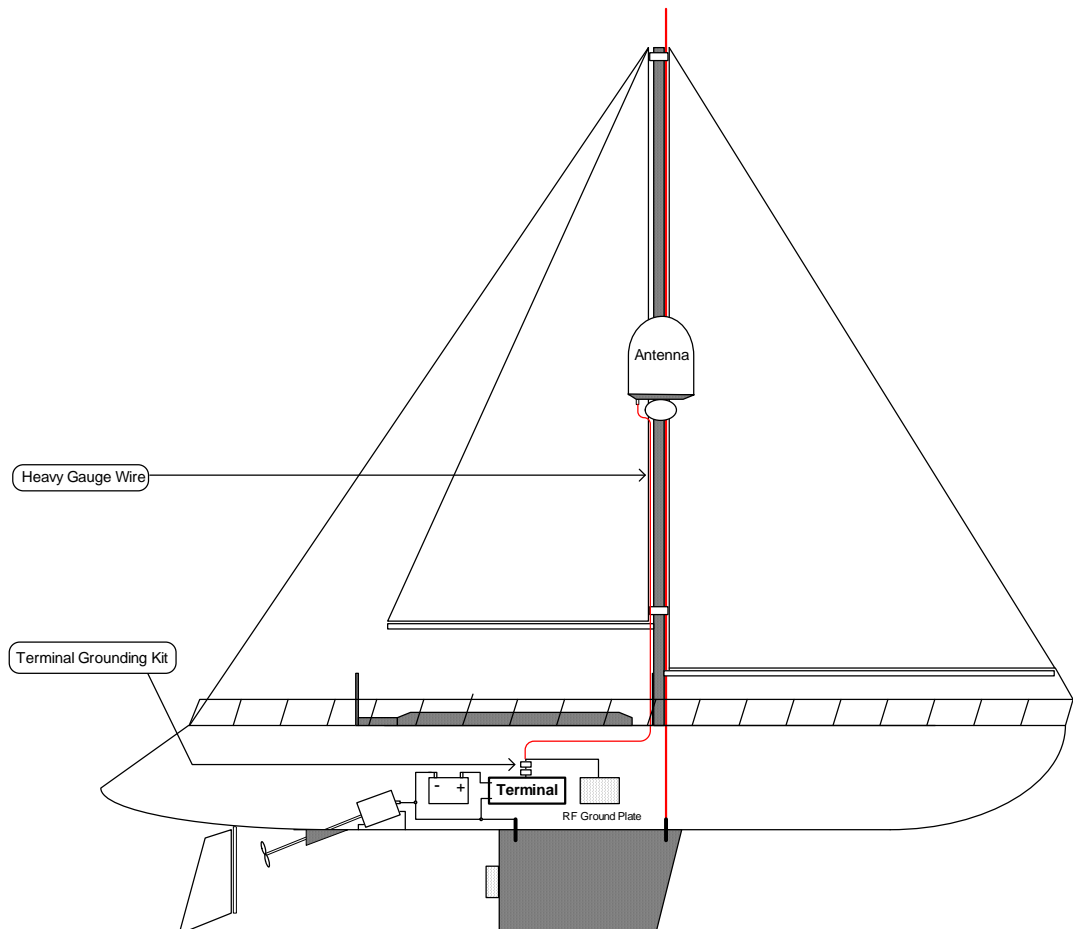

Alternative grounding for timber hulls

Grounding the terminal

The terminal must be grounded with the short antenna cable and the grounding kit (accessory). Further, the terminal must be grounded at its grounding stud in order to ensure a proper grounding if the short antenna cable is disconnected.

The ground connection must be established at a dedicated RF ground (either capacitive or electrical coupled). Bear in mind that the antenna ground connection is to be made at the **same electrical ground potential** as the terminal (see *Grounding the antenna*).

Grounding the antenna

If the mounting base of the antenna is electrically connected to any other ground potential than the terminal (e.g. Lightning Ground), the antenna must be isolated at its mounting bolts by means of shoulder bushings and washers - see page 68.

However, a ground connection must be established via one of the mounting bolts using a separate ground cable. The ground cable must be routed parallel and in close proximity to the shielded coax cable hence connecting the antenna to the terminal grounding kit. A tinned heavy gauge wire (min. 6 mm²) can be used for this purpose - see page 65.

Alternative grounding for timber hulls

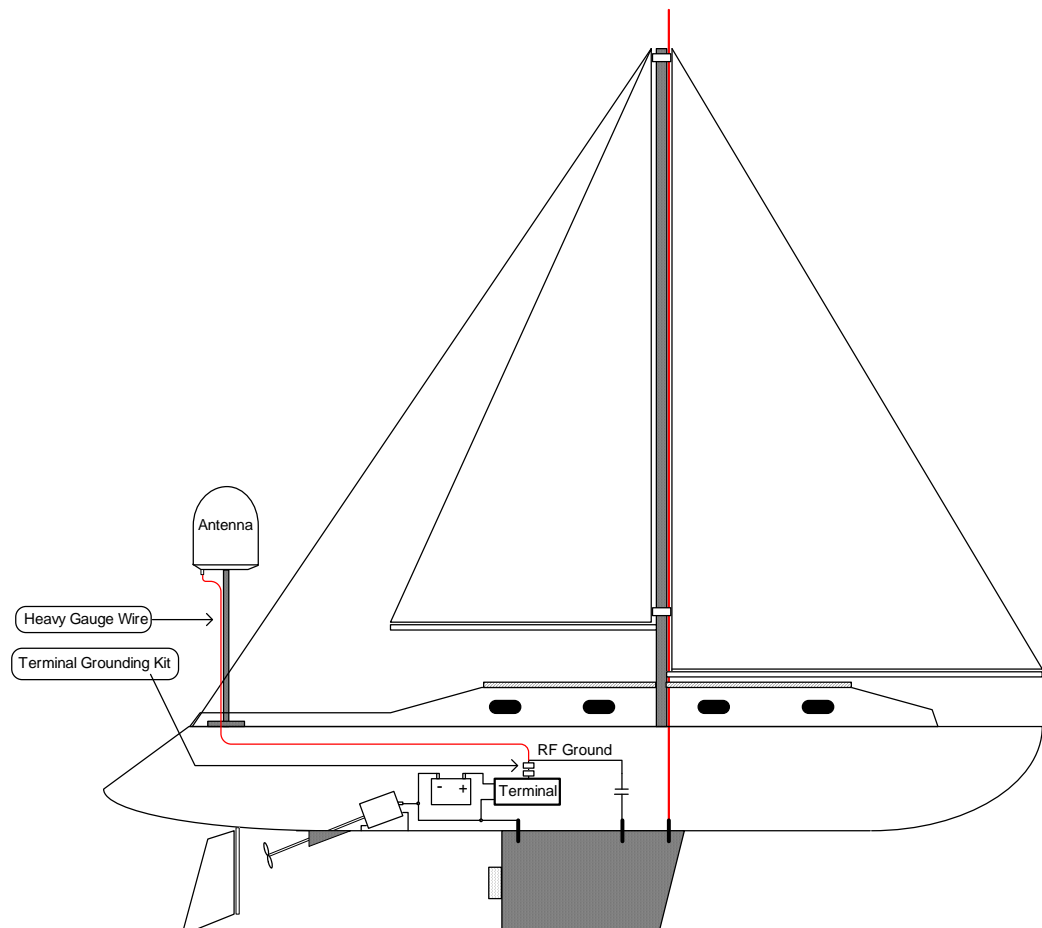

Separate ground cable

Ground cable - construction

When dealing with electrical installations in a marine environment, all wiring must be done with double insulated, tinned, high quality and if exposed also UV resistant cables. This shall also apply to the separate ground cable mentioned in the previous paragraphs.

The ground cable is constructed using an appropriate cable with a cross section area of at least 6 mm² (AWG10) and terminated with insulated ring crimp terminals – see illustration below. The crimp terminals must be a marine approved type e.g. the DuraSeal series from Raychem.

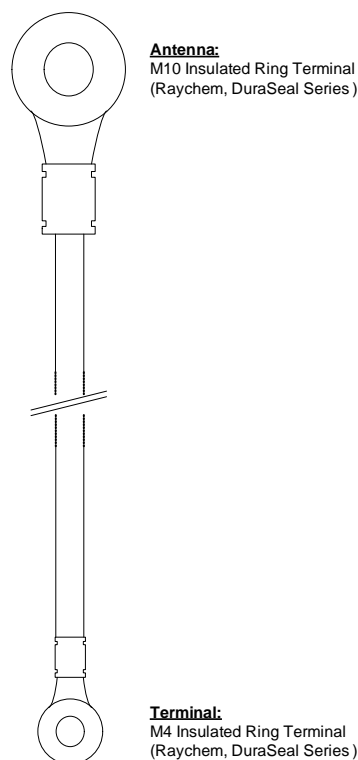

Ground cable - connection

The ground cable must be mounted parallel (and in close proximity) to the shielded coax cable thus minimizing ground loop problems. If possible, route the coax cable and the ground cable in metal conduits bonded to the hull or within a mast (depending on the actual installation).

The ground cable must be connected at one of the mounting/grounding bolts on the antenna. Use bolts and washers of stainless steel and seal the joint with protective coating to avoid corrosion. If the antenna is to be isolated from the mounting base, shoulder bushings and washers must be used - see page 68.

In the below drawing, vibration isolators are mounted.

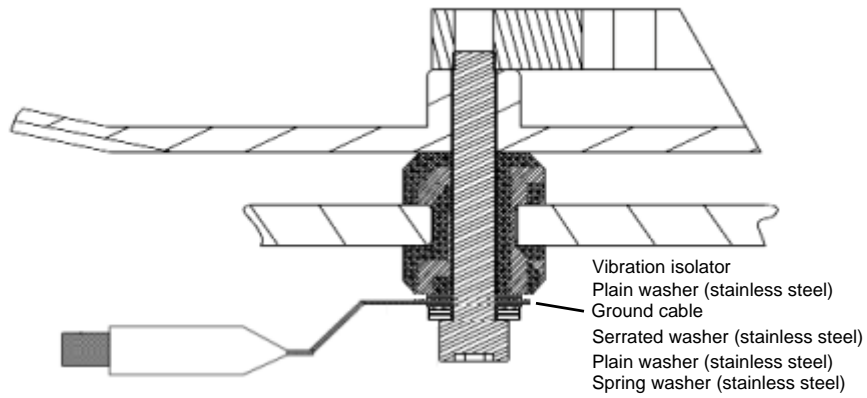

At the other end, connect the ground cable at the terminal grounding kit.

Isolation of the antenna from the mounting base

In cases where the antenna is to be isolated from the mounting base, shoulder bushings and washers (accessories) must be used as illustrated below. Please note that the isolation has to be implemented on all four mounting bolts (including the bolt securing the ground cable).

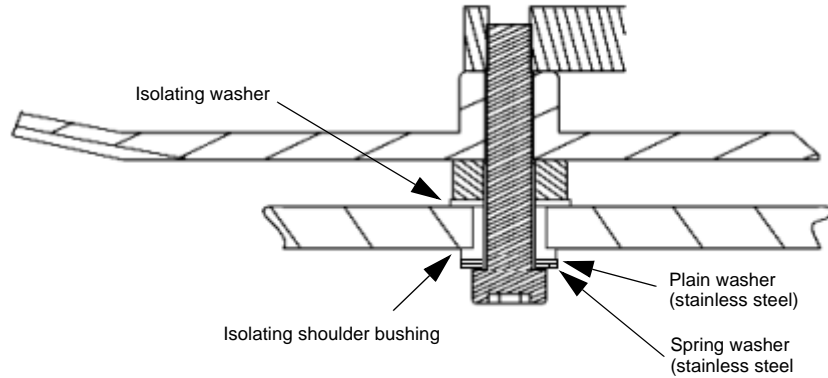

The ground cable must be connected at one of the mounting/grounding bolts on the antenna as illustrated below. Remember to seal the joint with protective coating to avoid corrosion.

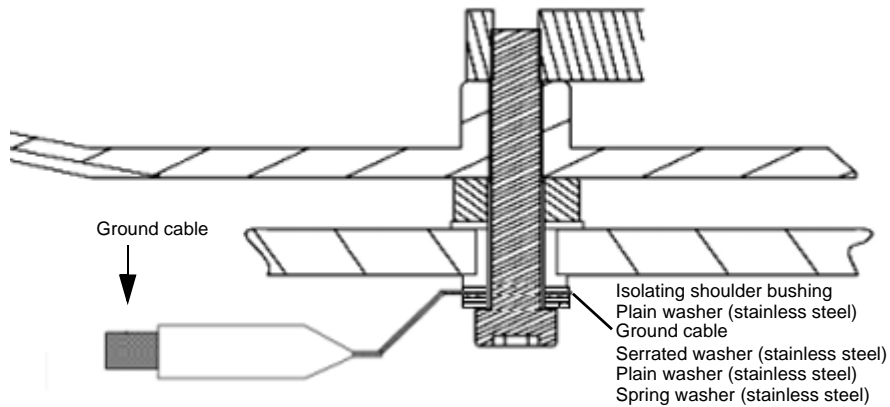

RF interference

Interference induced from nearby RF transmitters might cause system failures and in extreme cases permanent damage to the TracPhone equipment. If there are problems with interference from HF transmitters, it is advisable to mount ferrite clamps on the coax cable in order to provide suppression of induced RF. The ferrites will have no effect on the differential-mode signals but increases the impedance in relation to common-mode RFI.

Recommendations

Use 1-5 pcs. hinged clamp cores (e.g. the RFC or SFC series from Kitagawa) mounted on the antenna cable near the antenna.

Electrostatic Discharge

In addition to the RFI attenuation, mounting ferrite clamps on the antenna cable will also slow the fast rate-of-rise of an electrostatic discharge current pulse. This might be an issue during installation (antenna cable disconnected) where different electrical potentials have had the chance to build up between the terminal and antenna.

We recommend mounting 1-5 pcs. hinged clamp cores (e.g. the RFC or SFC series from Kitagawa) on the antenna cable near the antenna.

A

AWG American Wire Gauge. A means of specifying wire diameters.

C

CD Compact Disc

CM Continuous Monitoring

D

DTMF Dual Tone Multi Frequency. The keypad signaling technology that generates two distinct tones when each key is pressed. This system allows navigation of voice menus and other advanced calling services. All wireless phones use DTMF dialing.

E

ESD ElectroStatic Discharge

G

GPIO General Purpose Input/Output

H

HF High Frequency. The frequency band between 3 and 30 MHz. Used for medium and long range terrestrial radio communication.

I

I/O Input/Output

IP Internet Protocol. The method or protocol by which data is sent from one computer to another on the Internet.

L

LAN Local Area Network

P

PAST Person Activated Self Test. A test similar to the POST test, but activated by the user. The PAST causes the system to reset.

PC Personal Computer

PIN Personal Identification Number. A secret numeric password shared between a user and a system, used to authenticate the user to the system.

PoE Power over Ethernet. A standard for combining power supply with transmission of data over the Ethernet. The source unit "injects" power into the Ethernet cable and the power is "picked up" at the connected device.

POST Power On Self Test. A test sequence that runs every time the system is powered up or reset.

PUK Pin Unblocking Key

R

RF Radio Frequency. Electromagnetic wave frequencies between about 3 kilohertz and about 300 gigahertz including the frequencies used for communications signals (radio, television, cell-phone and satellite transmissions) or radar signals.

RFI Radio Frequency Interference. A non-desired radio signal which creates noise or dropouts in the wireless system or noise in a sound system.

S

SIM Subscriber Identity Module. The SIM provides secure storing of the key identifying a mobile phone service subscriber but also subscription information, preferences and storage of text messages.

SSB Single Side Band. A means of communications at sea. The range of SSB is up to several thousand miles and calls between yachts are free. Some stations allow telephone calls, email and some basic Internet services over SSB radio.

T

- TFTP** Trivial File Transfer Protocol. A very simple file transfer protocol, with the functionality of a very basic form of FTP. Since it is so simple, it is easy to implement in a very small amount of memory.
- TNC** Threaded Neill-Concelman. A type of RF connector used for terminating coaxial cables. The TNC connector is a threaded version of the BNC connector. The connector has a 50 Ohm

A

- alarms, 43
- aluminum hulls
 - grounding, 63
- analog phone interface, 28
- antenna
 - cables, 12
 - dimensions, 48
 - grounding, 12
 - grounding recommendations, 60
 - installation location, 5
 - installing, 12
 - interference, 6
 - isolation from mounting base, 68
 - mast design, 9
 - obstructions, 5
 - outline, 48
 - radiation, 5

C

- cable support, 17
- cables
 - antenna, 12
 - ground, 66
 - power, 19

D

- delivery
 - items included, 4
- diagnostic report, 43
- dimensions
 - antenna, 48
 - terminal, 53
- discrete I/O interface, 31
- distance
 - antenna to GPS receiver, 8
 - antenna to radar, 6
 - antenna to transmitters, 50
 - between Inmarsat antennas, 8

E

- electrostatic discharge
 - recommendations, 69
- error messages, 43
- events
 - logging, 43

F

- fiberglass hulls
 - grounding, 64

G

- GPS receiver
 - distance from antenna, 8
- grounding, 56
 - access, 15
 - aluminum hulls, 63
 - antenna, 12, 60
 - cable, 66
 - fiberglass hulls, 64
 - recommendations, 60
 - steel hulls, 61
 - terminal, 60
 - timber hulls, 65
- grounding the terminal, 16

H

- hardware interfaces, 24

I

- I/O interface, 31
- ignition function, 35
- indicators, function, 42
- installation
 - antenna, 12
 - terminal, 16

interfaces on terminal
 analog phone interface, 28
 antenna, 25
 DC power input, 26
 discrete I/O, 31
 LAN, 29
 overview, 24
interference, 6
 RF, 69
IP handset
 connecting, 30
 entering PIN with, 37
items included in delivery, 4

L

LAN interface, 29
light indicators, function, 42

M

mast for antenna, 9
measuring source impedance, 55
microwave radiation, iii

O

obstructions
 distance and size, 5
outline
 antenna, 48
 terminal, 53

P

part numbers, 44
Phone interface, 28
PIN
 entering in the web interface, 38
 entering with a phone, 37
 entering with IP handset, 37
pin-out
 analog phone interface, 28
 antenna interface, 25
 DC power input, 26
 discrete I/O interface, 31
 LAN interface, 30
placing the antenna, 5

placing the terminal, 15
PoE, 29
pole mount, 9
power
 cable, 19
 cable extension, 21
 connecting, 22
 connecting remote on/off, 23
 sources, 19
 switching on, 35
 using remote on/off, 35
power input on terminal, 26
Power over Ethernet, 29
PUK code, 37

R

radar
 distance from antenna, 6
radiation level, iii, 5
remote on/off
 connecting, 23
 using, 35
reset button
 accessing, 40
 functions, 41
RF interference
 recommendations, 69

S

safety summary, iii
SIM card
 inserting, 33
 removing, 34
source impedance
 measuring, 55
spare parts, 44
specifications, 45
steel hulls
 grounding, 61
system units
 terminal, 1

T

technical specifications, 45
 terminal, 51
temperature, 15

terminal

- cable support, 17
- grounding, 16
- grounding recommendations, 60
- installation location, 15
- installing, 16
- introduction, 1
- outline and dimensions, 53

timber hulls

- grounding, 65
- tools for operation, 39
- troubleshooting, 40
- typography used in this manual, vi

U

- user interfaces, 39

KVH Industries, Inc.

50 Enterprise Center • Middletown, RI 02842-5279 • U.S.A.
Phone: +1 401 847-3327 • Fax: +1 401 849-0045
E-mail: info@kvh.com



www.kvh.com

KVH Europe A/S

Kokkedal Industripark 2B • 2980 Kokkedal • Denmark
Phone: +45 45 160 180 • Fax: +45 45 160 181
E-mail: info@kvh.dk