

SIMRAD

HS75 User Manual

ENGLISH



Preface

Disclaimer

As Navico is continuously improving this product, we retain the right to make changes to the product at any time which may not be reflected in this version of the manual. Please contact your nearest distributor if you require any further assistance.

It is the owner's sole responsibility to install and use the equipment in a manner that will not cause accidents, personal injury or property damage. The user of this product is solely responsible for observing maritime safety practices.

NAVICO HOLDING AS AND ITS SUBSIDIARIES, BRANCHES AND AFFILIATES DISCLAIM ALL LIABILITY FOR ANY USE OF THIS PRODUCT IN A WAY THAT MAY CAUSE ACCIDENTS, DAMAGE OR THAT MAY VIOLATE THE LAW.

This manual represents the product as at the time of printing. Navico Holding AS and its subsidiaries, branches and affiliates reserve the right to make changes to specifications without notice.

Governing language

This statement, any instruction manuals, user guides and other information relating to the product (Documentation) may be translated to, or has been translated from, another language (Translation). In the event of any conflict between any Translation of the Documentation, the English language version of the Documentation will be the official version of the Documentation.

Compliance statements

Declarations

The relevant declarations of conformity and certificates are available at:
www.navico-commercial.com

Europe

Navico declare under our sole responsibility that the product conforms with the requirements of: CE under RED Directive 2014/53/EU.

United States of America

Warning: The user is cautioned that any changes or modifications not expressly approved by the party responsible for compliance could void the user's authority to operate the equipment.

Australia and New Zealand

Navico declare under our sole responsibility that the product conforms with the requirements of: Level 2 devices of the Radiocommunications (Electromagnetic Compatibility) standard 2017.

Copyright

Copyright © 2020 Navico Holding AS.

Warranty

The warranty card is supplied as a separate document.

In case of any queries, refer to our website:

www.navico-commercial.com

Trademarks

Navico® is a registered trademark of Navico Holding AS.

Simrad® is used by license from Kongsberg.

NMEA® and NMEA 2000® are registered trademarks of the National Marine Electronics Association.

Other trademarks are the properties of their respective owners.

Important text conventions

Important text that requires special attention from the reader is emphasized as follows:

→ **Note:** Used to draw the reader's attention to a comment or some important information.

! Warning: Used when it is necessary to warn personnel that they should proceed carefully to prevent risk of injury and/or damage to equipment/ personnel.

Contents

6 Introduction

- 6 Overview
- 6 Parts

7 Installation

- 7 Wiring guidelines
- 7 Mounting location
- 8 Mounting orientation
- 11 Wiring details

12 Dimensional drawings

13 Troubleshooting

14 Supported data

- 14 NMEA 2000 messages received based on a request
- 14 NMEA 2000 transmitted messages

18 Technical specifications

1

Introduction

Overview

The HS75 GNSS Compass supports GPS, GLONASS, Galileo, QZSS, and BeiDou satellites.

The HS75 GNSS antennas are separated by 20 cm (7.87") between phase centers, resulting in a heading performance of better than 0.75° RMS. The HS75 can provide heading and positioning updates at 10 Hz and delivers positioning accuracy of 0.6 m 95% of the time when using differential GPS corrections from Satellite Based Augmentation Systems (SBAS).

The HS75 houses the following:

Dual GNSS, multipath-resistant antennas

Six-axis rate sensor (gyro)

GNSS receivers and processors

Standard NMEA 2000 Micro-C port for power and data

The six-axis rate sensor improves system performance and provides backup heading information in the event a GNSS heading is not available due to signal blockage. The sensor provides a substitute heading, accurate to within 1° per minute for up to three minutes.

Parts

An HS75 installation requires the following parts:

Part name	Qty.
HS75 receiver	1
NMEA 2000 drop cable (not included)	1
Fastening screws (depending on mounting option, not included)	4
Cable ties	-

2

Installation

Wiring guidelines

Before mounting the HS75, consider the following regarding the NMEA 2000 cable routing:

- Avoid running the cable in areas of excessive heat.
- Keep cable away from corrosive chemicals.
- Do not run the cable through door or window jams.
- Keep cable away from rotating machinery.
- Do not crimp or excessively bend the cable.
- Avoid cable tension.
- Secure the cable along the cable route using cable ties.

Warning: Improperly installed cable near machinery can be dangerous.

Mounting location

This section provides information on determining the best location for the HS75. Choose a mounting location that will not expose the unit to conditions that exceed the technical specifications.

GNSS reception

Ensure that the HS75 has a clear view of the sky and that the view is not blocked by obstructions that may reduce system performance.

Position information is based on the primary GNSS antenna located at the opposite end of the housing to the recessed arrow (A) on the underside of the housing.

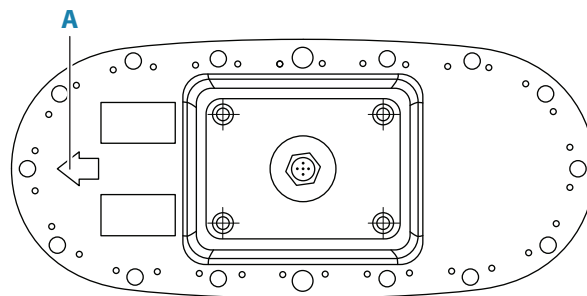

Make sure that any transmitting antennas are mounted away from the HS75 by at least 2 m (6.5 ft) to ensure tracking performance is not compromised. Refer to the documentation supplied with the transmitting antenna for minimum safe distances.

Distance to other GNSS/GPS antennas should be minimum 0.5 m (1.6 ft).

VHF interference

VHF interference from cellular phones and radio transmitters may interfere with GNSS operation.

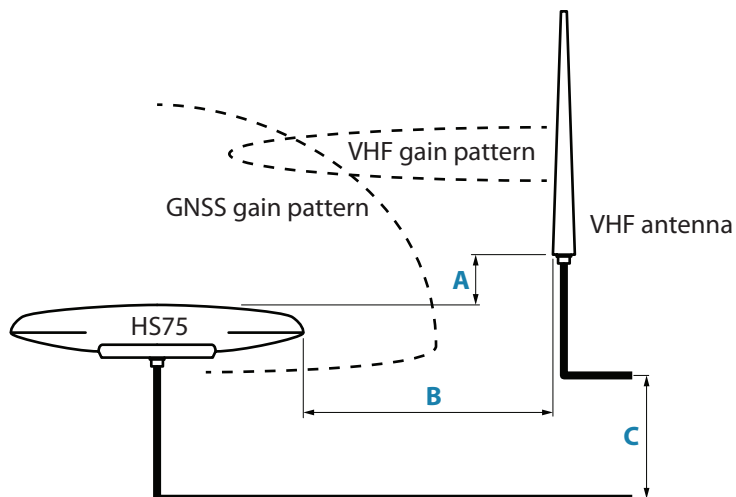

- A** Minimum horizontal spacing: 2 m (6.5 ft).
- B** Minimum vertical spacing: 2 m (6.5 ft).
- C** Minimum cable separation: 0.3 m (1 ft) for the first 5 m (16.5 ft).

Mounting orientation

Mount the HS75 parallel to, and along the centerline of the axis of the boat. Doing so, provides a true heading. The recessed arrow (**A**) under the antenna housing should point towards the bow of the vessel.

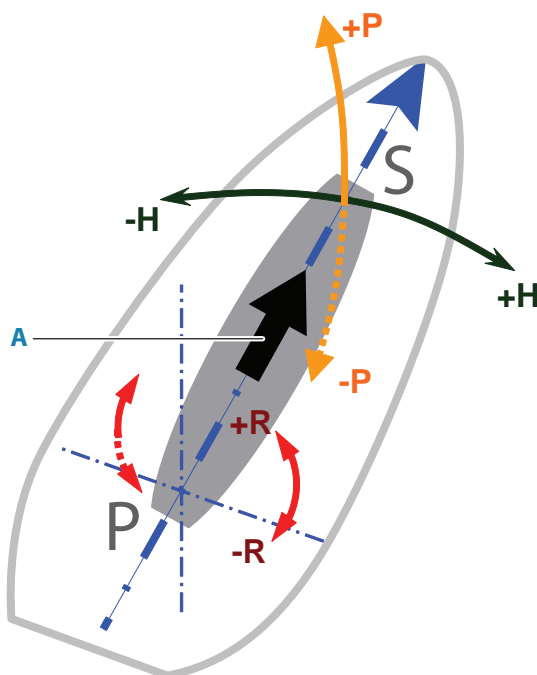

- You can enter a heading offset from a compatible display unit.
- You will have an offset in the pitch/roll output if the unit is not installed on a horizontal plane.

Alignment

The top of the enclosure incorporates sight design features to help you align the enclosure with respect to the vessel.

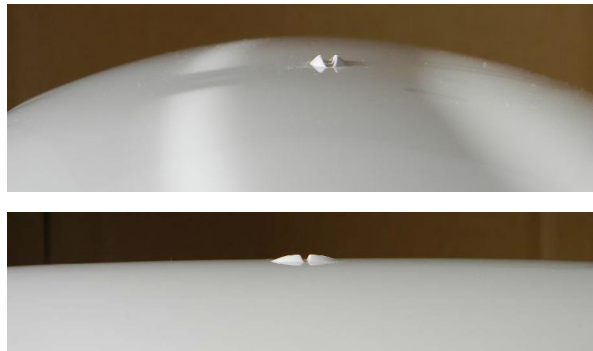

Alignment accuracy is approximately +/- 2°.

Mounting Options

The HS75 offers four different mounting options:

- Surface mounting options:
 - No adapter, HS75 is secured with screws from the underside of the mounting surface. Cable exits through the mounting surface.
 - Using a low profile adapter secured with screws from the top of the mounting surface. Cable exits through the mounting surface.
 - Using a high profile adapter secured with screws from the top of the mounting surface. Cable exits through the adapter, above the mounting surface.
- Pole Mounting

Surface mounting without an adapter

- 1 Use the supplied mounting template to mark and drill the required holes for the screws and the cable.
- 2 Place the HS75 over the mounting holes and insert the mounting screws (M8) through the bottom of the mounting surface into the HS75.
- 3 Tighten to a torque of 11 - 13 NM (8 - 10 lbs-ft). The maximum thread depth engagement must be no more than 12 mm (0.50").
- 4 Connect the NMEA 2000 drop cable to the HS75.

Surface mounting with adapter

- 1 Secure the upper adapter to the HS75 using the supplied mounting hardware. Tighten to a torque of 11 - 13 Nm (8 - 10 lbs-ft). The maximum thread depth engagement must be no more than 12 mm (0.50").



- Use the lower part of the adapter as a template and mark and drill holes (**x1 - x4**) for the screws. For the low profile adapter (**A**) where the cable exits through the bottom, also mark and drill a hole for the cable. For the high profile lower adapter (**B**) where the cable exits above the mounting surface, no cable hole is required.

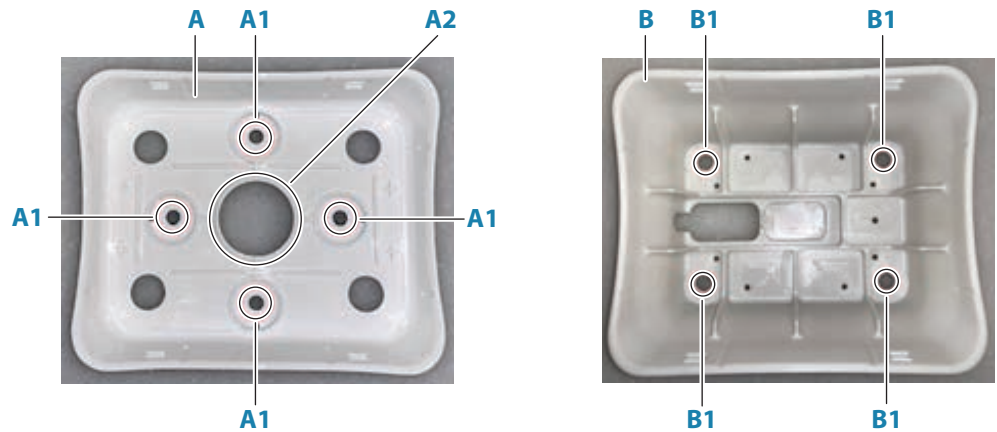

- Route the cable through the adapter and secure the lower adapter to the installation surface. Tighten to a maximum torque of 13 Nm (10 lbs-ft).
 - Connect the NMEA 2000 drop cable to the HS75 and place the HS75 assembly into the lower adapter so that the four latches snap into place.
- **Note:** To remove the HS75, press in the clips on one side, at which point the HS75 can easily be removed.

Pole mounting

- Screw the jam nut onto the 1-inch pole, then screw the pole mount bracket onto the pole. Do not tighten the pole mount to more than 5.4 Nm (4 lbs-ft).



- Feed the cable either through the hollow pole or through the opening in the pole mount bracket.
- Connect the NMEA 2000 drop cable to the HS75, then secure the pole mount bracket to the HS75 using the supplied mounting hardware. Tighten to a torque of 11 - 13 Nm (8 - 10 lbs-ft). The maximum thread depth engagement must be no more than 12 mm (0.50").



- 4 Verify the orientation of the HS75, then tighten the jam nut to the bottom of the pole mount bracket to a torque of 11 - 13 Nm (8 – 10 lbs-ft).



Wiring details

The HS75 has a standard NMEA 2000 Micro-C connector, used for both power and data communication.

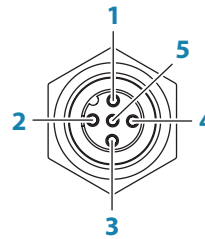

Pin	Purpose
1	Shield
2	NET-S (+12 V DC)
3	NET-C (DC negative)
4	NET-H
5	NET-L

Electrical isolation

The HS75 power supply is isolated from the communication lines and the PC-ABS plastic enclosure isolates the electronics mechanically from the vessel (addressing the issue of vessel hull electrolysis).

3

Dimensional drawings

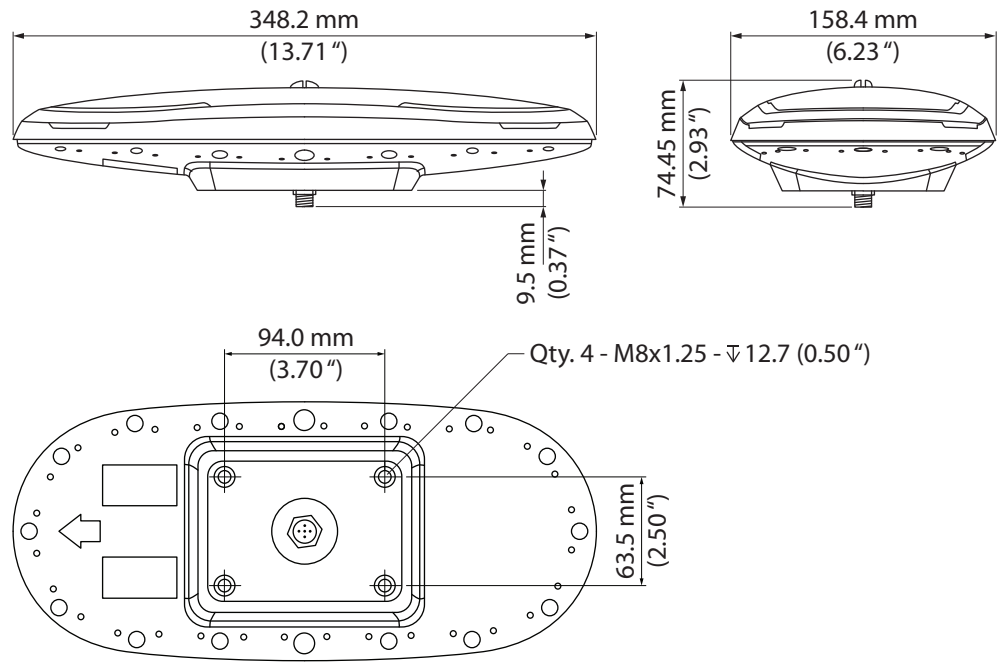

4

Troubleshooting

Symptom	Possible solution
Receiver fails to power	<ul style="list-style-type: none">• Verify that the NMEA 2000 backbone is powered.• Check the voltage coming out of the connector at the end of the cable.• Check current restrictions imposed by power source (minimum available should be > 1.0 A).
No data from the HS75	<ul style="list-style-type: none">• Verify that the NMEA 2000 backbone is powered.• Check integrity and connectivity of cable connections.
No GNSS lock	<ul style="list-style-type: none">• Verify the HS75 has a clear view of the sky.
No SBAS lock	<ul style="list-style-type: none">• Verify the HS75 has a clear view of the sky.• SBAS lock is only possible if you are in an appropriate SBAS regions. Currently, there is limited SBAS availability in the southern hemisphere.
No heading or incorrect heading value	<ul style="list-style-type: none">• Monitor the number of satellites and SNR values for both antennas in the Simrad display unit. At least four satellites should have a strong SNR value in both antennas.• Heading is from primary GNSS antenna to secondary GNSS antenna, so the arrow on the underside of the HS75 is directed to the bow.

5

Supported data

NMEA 2000 messages received based on a request

PGN	Description	Default update rate (msec)	Freq (Hz)
059392	ISO Acknowledgement Used to acknowledge the status of certain requests addressed to a specific ECU.	On Request	On Request
059904	ISO Request Request the transmission of a specific PGN, addressed or broadcast.	On Request	On Request
060928	ISO Address Claim Used to identify to other ECUs the address claimed by an ECU.	On Request	On Request
126996	Product Information NMEA 2000 database version supported, manufacturer's product code, NMEA 2000 certification level, Load Equivalency number, and other product- specific information.	On Request	On Request
126464	Receive/Transmit PGNs group function The Transmit / Receive PGN List Group type of function is defined by the first field.	On Request	On Request
129545	GNSS RAIM Output Used to provide the output from a GNSS receiver's Receiver Autonomous Integrity Monitoring (RAIM) process. The Integrity field value is based on the parameters set in PGN 129546 GNSS RAIM Settings.	On Request	On Request
129546	GNSS RAIM Settings Used to report the control parameters for a GNSS Receiver Autonomous Integrity Monitoring (RAIM) process.	On Request	On Request

NMEA 2000 transmitted messages

PGN	Description	Default update rate (msec)	Freq (Hz)
126992	System Time The purpose of this PGN is twofold: To provide a regular transmission of UTC time and date, and to provide synchronism for measurement data.	1000	1
126993	Heartbeat Confirms a device is still present on the network.	60000	1/60

PGN	Description	Default update rate (msec)	Freq (Hz)
127250	<p>Vessel Heading</p> <p>Heading sensor value with a flag for True or Magnetic.</p> <p>If the sensor value is Magnetic, the deviation field can be used to produce a Magnetic heading, and the variation field can be used to correct the Magnetic heading to produce a True heading.</p>	100	10
127251	<p>Rate of Turn</p> <p>Rate of change of heading.</p>	100	10
127257	<p>Altitude</p> <p>Provides a single transmission that describes the position of a vessel relative to both horizontal and vertical planes.</p> <p>Altitude can be used for vessel stabilization, vessel control and onboard platform stabilization.</p>	1000	1
127258	<p>Magnetic Variation</p> <p>Message for transmitting variation.</p> <p>The message contains a sequence number to synchronize other messages such as Heading or Course over Ground.</p> <p>The quality of service and age of service are provided to determine appropriate level of service if multiple transmissions exist.</p>	1000	1
129025	<p>Position, Rapid Update</p> <p>Provides latitude and longitude referenced to WGS84.</p> <p>A single frame message (opposed to other PGNs that include latitude and longitude and are defined as fast or multi- packet), this PGN lends itself to more frequent transmission without using excessive bandwidth.</p>	100	10
129026	<p>COG & SOG, Rapid Update</p> <p>Single frame PGN that provides Course Over Ground (COG) and Speed Over Ground (SOG).</p>	250	4

PGN	Description	Default update rate (msec)	Freq (Hz)
129027	<p>Position Delta, High Precision Rapid Update</p> <p>The 'Position Delta, High Precision Rapid Update' Parameter Group is for applications requiring high precision and very fast update rates for position data.</p> <p>This PGN provides delta position changes down to 1 mm with a delta time period accurate to 5 msec.</p>	100	10
129028	<p>Altitude Delta, High Precision Rapid Update</p> <p>The 'Altitude Delta, High Precision Rapid Update' Parameter Group is intended for applications requiring high precision and fast update rates are needed for altitude and course over ground data.</p> <p>This PGN can provide delta altitude changes down to 1 millimeter, a change in direction as small as 0.0057°, and with a delta time period accurate to 5 msec.</p>	100	10
129029	<p>GNSS Position Data</p> <p>Conveys a comprehensive set of Global Navigation Satellite System (GNSS) parameters, including position information.</p>	1000	1
129033	<p>Time & Date</p> <p>Single transmission that provides UTC time, UTC Date, and Local Offset.</p>	1000	1
129539	<p>GNSS DOPs</p> <p>Provides a single transmission containing GNSS status and dilution of precision components (DOP) that indicate the contribution of satellite geometry to the overall positioning error.</p> <p>Three DOP parameters are reported: horizontal (HDOP), Vertical (VDOP), and time (TDOP).</p>	1000	1
129540	<p>GNSS Sats in View</p> <p>GNSS information on current satellites in view tagged by sequence ID.</p> <p>Information includes PRN, elevation, azimuth, SNR, defines the number of satellites; defines the satellite number and the information.</p>	1000	1
129033	<p>Local Time Offset</p> <p>Indicates offset between a configured local time and UTC. As of currently we do not support a local time, so this always reports no offset.</p>	On Request	On Request

PGN	Description	Default update rate (msec)	Freq (Hz)
126998	Configuration Information Used for returning fields describing an installation. Currently always returns blank.	On Request	On Request

6

Technical specifications

Sensor and positioning accuracy	
Receiver type	Vector sFreq GNSS Compass
Signals Received	GPS, GLONASS, BeiDou, Galileo, QZSS1
Channels	422
GPS sensitivity	-142 dBm
SBAS tracking	2-channel, parallel tracking (WAAS, EGNOS, MSAS)
Update rate (position and heading)	10 Hz standard
Positioning accuracy	1.2m RMS, (no SA) 0.3m RMS, (SBAS)
Heading accuracy	0.75° RMS
Heave accuracy (GNSS)	30 cm
Pitch/Roll accuracy	1.5° RMS
Rate of turn	90°/s maximum
Cold start	60 s typical (no almanac or RTC)
Warm start	20 s typical (almanac and RTC)
Hot start	1 s typical (almanac, RTC, and position)
Heading fix	10 s typical (valid position)
Maximum speed	1,850 kph (999 kts)
Maximum altitude	18,288 m (60,000 ft)
Compass safe distance	50 cm
Communication	
Connector	NMEA 2000 Micro C
Power	
Input voltage	6 - 36 V DC
Power consumption	3.2 W (multi-GNSS, typical continuous draw at 12 V)
Power isolation	Isolated to enclosure
Reverse polarity protection	Yes
Mechanical	
Weight (no mount)	0.75 kg
Dimensions (no mount)	L 34.8 cm x W 15.8 cm x H 6.5 cm L 13.7" x W 6.2" x H 2.6"
Aiding Devices	
Six-axis rate sensor (gyro)	Provides smooth heading, fast heading reacquisition and reliable 1° per minute heading for periods up to 3 minutes when loss of GNSS has occurred.
Tilt Sensor	Provides pitch and roll data and assist in fast start-up and reacquisition of heading solution.
Environmental	
Operating temperature	-40°C to + 70°C (-22°F to + 158°F)
Storage temperature	-40°C to + 85°C (-40°F to + 185°F)
Humidity	95% non-condensing
Enclosure	ISO 60529:2013 for IPx6/IPx7/IPx9
Vibration	IEC 60945:2002 Section 8.7 Vibration
EMC	IEC60945:2002 EN 301 489-1 V2.1.1 EN 301 489-5 V2.1.1 EN 301 489-19 V2.1.0 EN 303 413 V1.1.1

SIMRAD

