

OWNER'S MANUAL

M3-101B

Marine Subwoofer with Built-In RGB LED Lighting (optional)

*Thank you for choosing a JL Audio Marine Subwoofer.
With proper installation, your new speaker will deliver
years of listening pleasure.*

*We strongly recommend that you have your subwoofer
installed by your authorized JL Audio dealer.*

*The installation professionals employed by your dealer have
the necessary tools and experience to properly install this product.*

*If you prefer to perform your own installation,
please read this instruction manual completely before
beginning the process.*



PHYSICAL SPECIFICATIONS

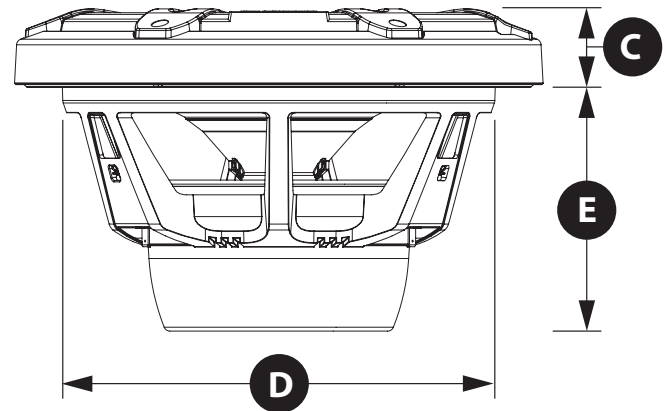
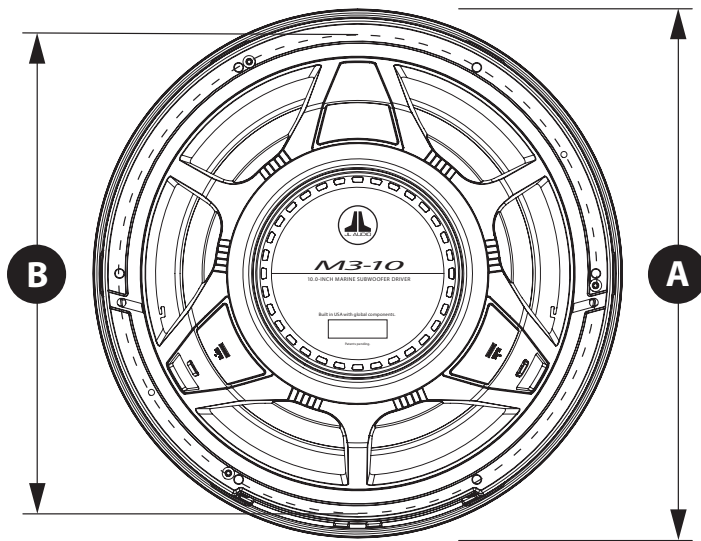

Subwoofer Physical Specifications	
Nominal Diameter	10 in / 250 mm
Outer Diameter (A)	10.75 in / 273 mm
Bolt Hole Circle (B)	9.71 in / 247 mm
Frontal Grille Protrusion-Classic* (C)	1.50 in / 38 mm
Frontal Grille Protrusion-Sport* (C)	1.58 in / 40 mm
Mounting Hole Diameter (D)	8.875 in / 225 mm
Mounting Depth (E)	5.00 in / 127 mm
Net Weight	12.60 lbs / 5.70 kg
Driver Displacement	0.52 ft ³ / 1.47 litres

* Frontal grille protrusion measured from mounting surface (Sport Grille Pictured)

INCLUDED PARTS

- One Polymer Subwoofer Grille
- Six #8 x 1 1/2-inch (38 mm) Phillips pan-head stainless-steel screws
- Six #8 stainless-steel washers
- Logo Badges
 - One Pair Black (Gunmetal Sport Models Only)
 - One Pair White (White Sport Models Only)

LED Equipped Models

Built-in, RGB LED lighting delivers beautiful accent illumination. LED functionality requires separate wiring at each speaker location. Adjustable control of RGB lighting requires the use of an RGB lighting controller (sold separately). For optimal performance, we recommend using the JL Audio marine lighting controller (MLC-RW).

Subwoofer Parameters	M3-10IB
Free Air Resonance (Fs):	41.84 Hz
Electrical "Q" (Qes):	0.806
Mechanical "Q" (Qms):	11.751
Total Speaker "Q" (Qts):	0.754
Equivalent Compliance (Vas):	1.29 ft ³ / 36.53 litres
One-way, Linear Excursion (Xmax)*:	0.42 in / 10.7 mm
Efficiency (1W/1m)**:	87.23 dB SPL
Effective Piston Area (Sd):	50.68 in ² / 0.0327 m ²
DC Resistance (Re):	3.957 ohm
Nominal Impedance:	4 ohm
Infinite Baffle Use:	Yes (Preferred)
Enclosure Use:	Yes (Sealed Only)
Power Handling (continuous):	175W

* Xmax specifications are derived via one-way voice coil overhang method with no correction factors applied.

** Efficiency (1W/1m) is not an accurate indicator of a subwoofer's output capability and should not be used as a comparison to other subwoofers to determine which one is "louder"!

We recommend the use of this speaker in a bi-amplified system using high-quality satellite speakers and amplifiers. We do not recommend the use of this subwoofer with a passive crossover (coil), as this type of device will adversely affect performance.

!! CAUTION

While this speaker is designed to be water and spray resistant, it is not designed to be submerged or to withstand high-pressure water spray. Do not install on submersibles, personal watercraft or any other vessel likely to be under water at any time.

Please exercise care when washing your boat to avoid damaging your speaker. Avoid contact with harsh chemicals or cleaning agents to prevent damage to the speaker's finish that will not be covered under warranty. Wash with mild soap and rinse with freshwater only.

Prolonged exposure to sound pressure levels in excess of 100dB can cause permanent hearing loss. This high-performance speaker can exceed this level. Please exercise restraint in its operation in order to preserve your ability to enjoy its fidelity.

When installing a subwoofer in your vessel, it is extremely important to secure it firmly. This applies not only to the woofer itself, but also any structure it is mounted to. If not firmly attached, the speaker can become dangerous projectile in a collision. Please review the mounting information carefully and use the supplied marine-grade hardware to mount this product.

!! WARNING

It is absolutely vital that your speaker is connected as shown in this manual. Failure to connect the system as shown will result in damage to your speakers which is NOT covered under warranty.

Do not attempt to remove the lighting LEDs from the grille. The LEDs are permanently fixed to the grille and their wiring is permanently fixed and attempting to remove them will cause damage and this damage will not be covered under warranty.

ENCLOSURE SPECIFICATIONS

The M3-10IB subwoofer is designed for infinite-baffle operation with a large volume of air behind it (at least 2 cu. ft. / 56.6 l). For best performance, the installation location/compartments must remain unoccupied and free of boating equipment (safety gear, life jackets, etc.). If you decide to build a dedicated enclosure, you may refer to the suggested design below.

Subwoofer	Recommended Sealed Design				
	Volume (net int.)	External Dimensions (Width x Height x Depth)	F3 (Hz)	Fc (Hz)	Qtc
M3-10IB	2.00 ft ³ 56.6 litres	18 in. x 18 in. x 14.5 in. 457 mm x 457 x 368 mm	42.9	53.66	0.967

NOTE: The enclosure recommendations listed are external dimensions which assume the use of 3/4" (19mm) thick material. If you are using 5/8" (16mm) thick material, subtract 1/4" (6.5mm) from each dimension. Do not use any material with a thickness of less than 5/8" (16mm) as this may compromise the rigidity of the enclosure.

NOTE: All enclosure volumes listed are net internal volumes! Box volume displacement, port displacement and brace displacement must be added to obtain the final gross internal volume. All enclosure dimensions listed have already taken this into account.

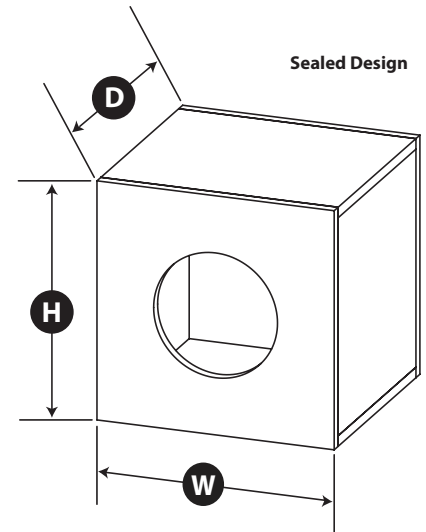

INTEGRATED RGB LED LIGHTING

Illuminated speaker models are outfitted with multi-color LEDs to produce vibrant accent lighting. Embedded within each speaker grille are six RGB LEDs, positioned and concealed from direct sight. Wire leads exiting from behind the grille includes LED connections. Refer to the table below for individual RGB wire connection info.

Note: Wiring connections at each speaker location are required for LED functionality.

Wire Color	RGB LED Connection
Red	Red RGB LED Negative (-)
Green	Green RGB LED Negative (-)
Blue	Blue RGB LED Negative (-)
Yellow	Main RGB LED Positive (+12V)

Adjustable control of RGB lighting may be achieved with the use of an RGB lighting controller (sold separately). Refer to the instructions of your RGB lighting controller for specific connection info. **Note: When selecting an RGB lighting controller, make sure that the total amperage demands of all LED circuits does not exceed the output capacity of the controller. Refer to the table below for the individual current draw amounts and sum (add) the total.** For optimal performance, we recommend using the JL Audio marine lighting controller (MLC-RW).

RGB LED SPECIFICATIONS

Specification	M3-101B
LED Current Draw at 12V DC	108 mA
Recommended Fuse Value	150 mA
LED Voltage Range	10 - 14.4V DC

DIRECT LED WIRING

Alternatively, you may hard wire individual leads or a combination of leads to achieve up to seven different LED color assortments. Refer to the table below for the wire colors used to achieve specific LED colors.

LED Color	Wire Color(s)	Connection
Red	Red	Combine selected wires from all speakers and connect to negative ground or to the negative (-) battery post.
Green	Green	
Blue	Blue	
Yellow	Red and Green	
Pink	Red and Blue	
Aqua	Green and Blue	
White	Red, Green and Blue	
Combine all YELLOW (+12V) leads together (parallel) and connect to a switched +12V supply. See below for additional info.		

LED WIRING CONSIDERATIONS

- Do not connect to 24V electrical systems.
- Do not connect the speakers' LED lights to the vessel's navigational lighting circuits.
- For short-circuit protection, we recommend installing a fuse (not included) at EACH speaker's YELLOW (+12V) LED power connection lead. Refer to the **RGB LED Specifications** table (at left) for recommended fuse ratings.
- We recommend a minimum of 16AWG wire size for each speaker's LED connection circuits.
- In addition to the above, we recommend activating the speakers' LEDs thru a cabin/interior lighting circuit that supplies +12V via an existing switch. If an existing switched circuit is not available, you may install a dedicated toggle/rocker style switch that will supply positive (+12V) power. Fuse this main +12V connection according to the total amperage demands of all LED circuits. Refer to the **RGB LED Specifications** table (at left) for individual current draw amounts and recommended fuse ratings.

BEFORE YOU BEGIN INSTALLING

- Check with your local waterway authority for any regulations regarding the use of accent/speaker lighting on your vessel.
- Turn off the audio system. It is also advisable to disconnect your battery system whenever performing installation work.
- Before cutting, drilling or inserting any screw, check clearances on both sides of the planned mounting surface. Also check for any potential obstacles, such as wiring harnesses, fuel lines, hydraulic lines, etc. Check both sides of the vessel before cutting any holes.
- If you are running cables through bulkheads, drill holes for the cable and use a urethane or plastic grommet to protect the wire from chafing in the hole. Make sure that the cables will clear any mechanical devices in the boat and secure them with wire ties.
- Wear protective eyewear at all times and a dust mask and gloves when drilling or cutting.

INSTALLATION PROCEDURE

Diagrams A & B (page 7) shows typical installation procedures into a fiberglass panel, using the supplied hardware. Always follow proper safety procedures. Use eye-protection at all times and a dust mask and gloves when cutting.

- 1) Choose a flat mounting surface that has sufficient depth and air space behind it to accept the subwoofer.
- 2) Using a hole saw or jigsaw, cut a 8.875-inch (225 mm) diameter hole.
- 3) Route the speaker cable to the mounting location. For LED equipped models, now is also a good time to run wires to the speaker location for LED activation.
- 4) Place the woofer in the hole and mark the screw hole locations using a sharp, pointed tool.
- 5) Remove the woofer and drill a pilot hole (see the Pilot Hole Recommendations chart at the right) in each of the screw locations. It is also advisable to use a hand-driven countersink tool on each hole to further inhibit gel-coat cracking of fiberglass panels.
- 6) Connect the speaker wires from the amplifier to the woofer connections (see Speaker Connections at right).
- 7) If equipped, connect the LED circuit leads (see page 5).
- 8) Place the woofer, with its grille in place, into the opening and while holding the speaker firmly in its mounting location, evenly snug the mounting screws in a criss-cross pattern, then hand tighten in a criss-cross pattern.

Non-standard installations may require different hardware. Always use marine-grade, stainless-steel fasteners to ensure a secure, reliable installation.

SPEAKER CONNECTIONS

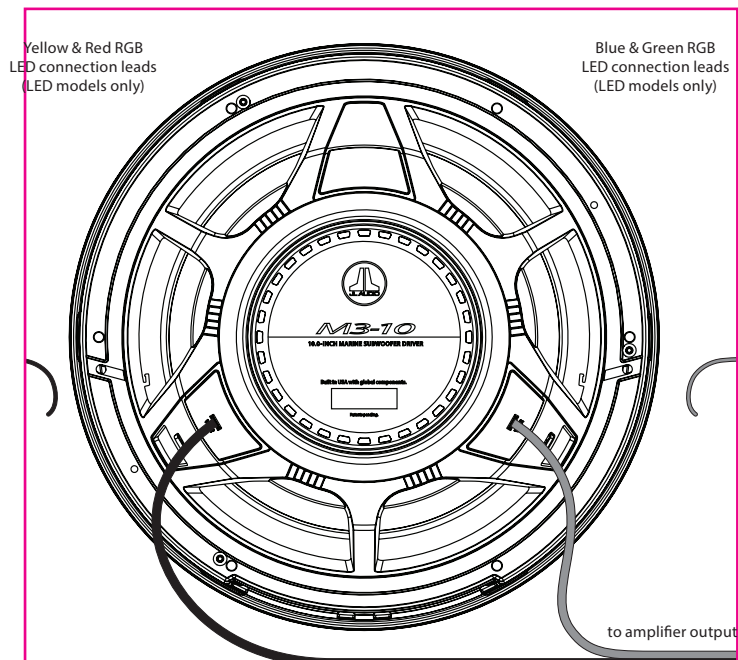

#8 SCREW: PILOT HOLE RECOMMENDATIONS

Fiberglass Thickness	Recommended Pilot Hole Drill Size
0.125 in. (3.18 mm) or less	7/64 in. (2.78 mm) pilot hole
foam core / fiberglass sandwich	7/64 in. (2.78 mm) pilot hole
larger than 0.125 in (3.18 mm)	1/8 in. (3.18 mm) pilot hole

DIAGRAM A
Classic Grille Model Installation

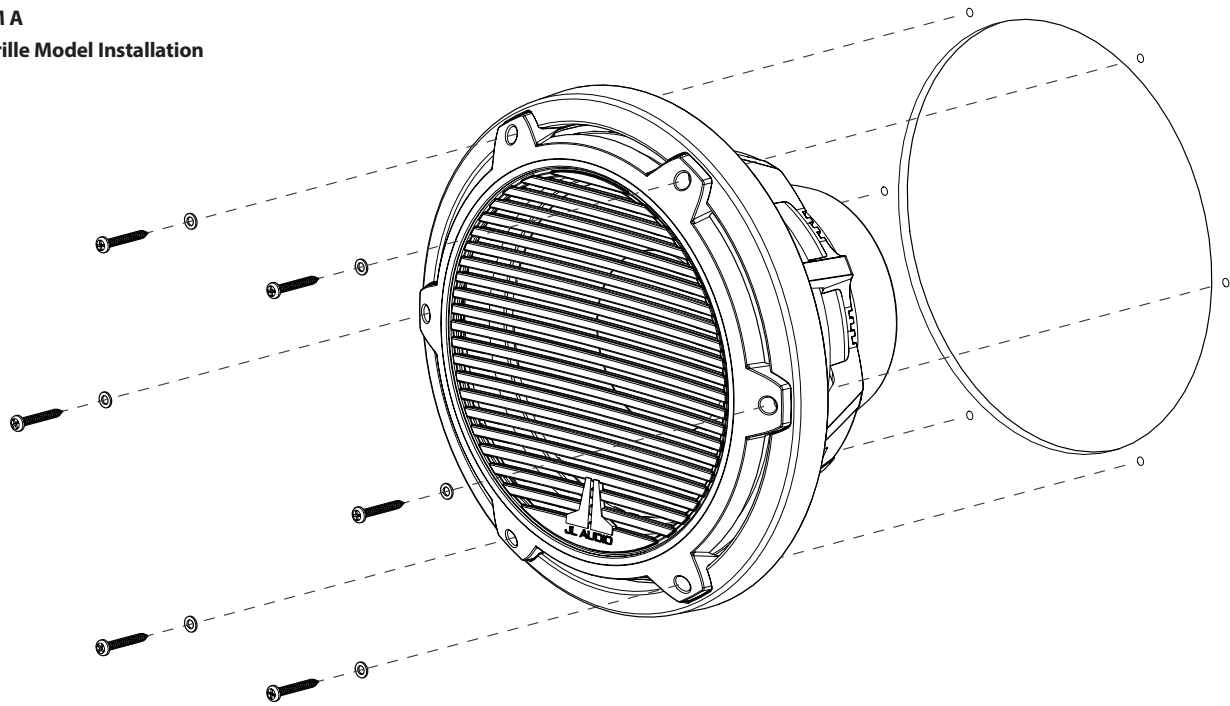
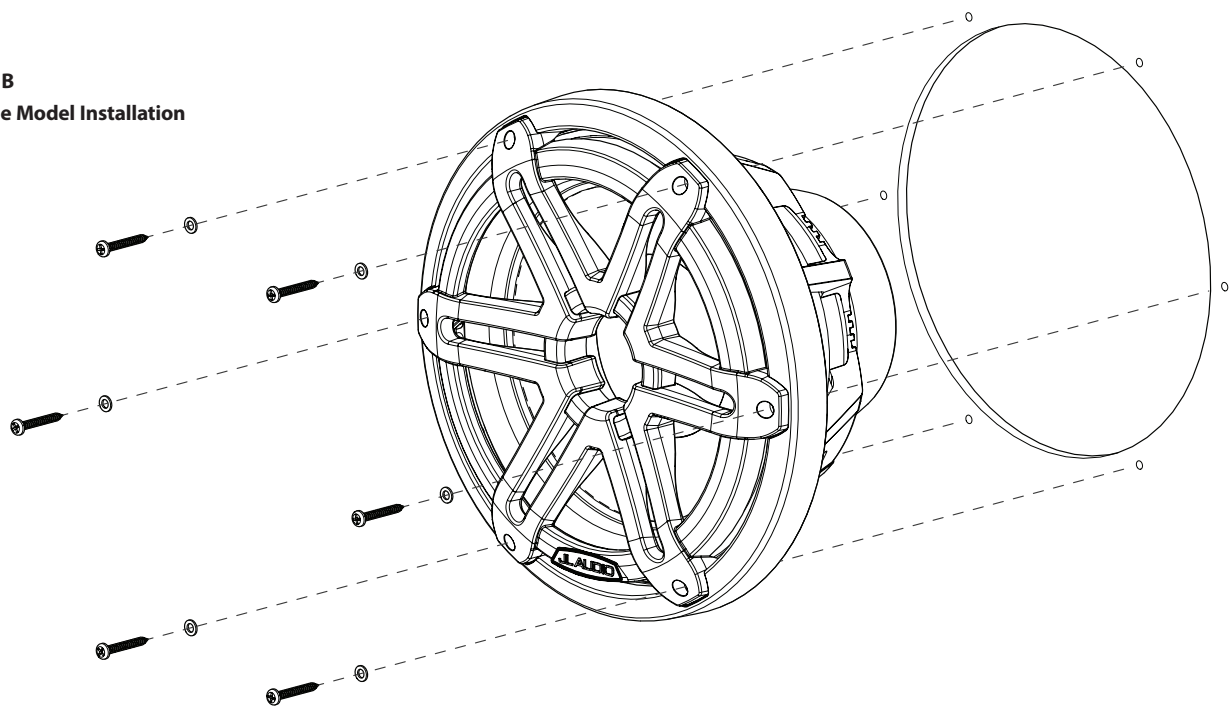
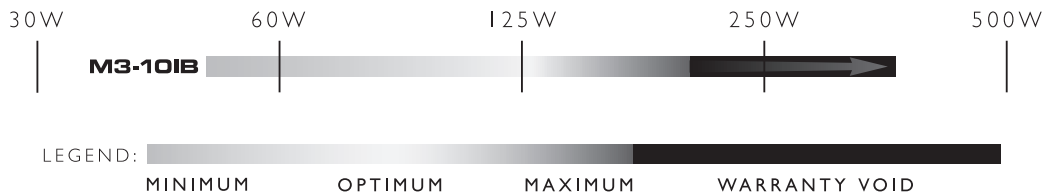

DIAGRAM B
Sport Grille Model Installation



RECOMMENDED CONTINUOUS (RMS) POWER RANGE FOR ONE SUBWOOFER DRIVER:



MEDIUM GRAY (MINIMUM):

From a reliability standpoint, this zone represents a very comfortable operating power range for each driver. This level of power will not stress the woofer but will not extract all of its performance potential, either.

Use of less than the minimum power level will not damage the woofer, but may result in unsatisfactory performance.

LIGHT GRAY (OPTIMUM):

This zone represents the best compromise between long-term reliability, high-output and low-distortion performance. This power level is lower than the woofer's continuous power rating (as published in its specifications), but you will still be taking advantage of the woofer's, low-distortion performance range without undue risk of failure.

DARK GRAY (MAXIMUM):

Slightly more SPL will be gained by pushing the power into this zone, but typically not more than 2dB, compared to the light gray zone. The subwoofer driver is designed to operate safely up to this power range, but not beyond. Operate with caution.

BLACK (WARRANTY VOID):

We do not recommend operating woofers at this level of power. In this zone, there is a very high probability that the driver will fail due to excessive heat and/or mechanical stress.

Subwoofer drivers operated at these levels of power are NOT covered under warranty.

When designing systems with our drivers, it is very important to achieve a good power match between the subwoofer amplifier and the subwoofer driver's capabilities. The power levels listed in the above chart represent continuous (RMS) amplifier power per woofer and assume that the user will regularly make full use of that power without drastically overdriving the amplifier(s). Make sure you factor system impedance and the total number of subwoofers into your calculations. Adhering to these power recommendations will result in systems that are both reliable and enjoyable.

JL AUDIO LIMITED WARRANTY (USA)

Marine Subwoofer Components

JL AUDIO warrants this speaker to be free of defects in materials and workmanship for a period of **two (2) years** from the original date of purchase.

This warranty is not transferable and applies only to the original purchaser of the product from an authorized JL AUDIO dealer. Warranty is voided if the factory-applied product serial number is removed or defaced.

Damage caused by the following is not covered under warranty: accident, misuse, abuse, product modification or neglect, failure to follow installation instructions, unauthorized repair attempts, misrepresentations by the seller. This warranty does not cover incidental or consequential damages and does not cover the cost of removing or reinstalling the unit(s). Cosmetic damage due to accident or normal wear and tear is not covered under warranty.

Should service be necessary under this warranty for any reason due to manufacturing defect or malfunction, JL AUDIO will, at its discretion, repair or replace the defective product with new or remanufactured product at no charge.

Products installed as original equipment by boat manufacturers are covered by the boat manufacturer's warranty, not JL Audio, Inc.

Any applicable implied warranties are limited in duration to the period of the express warranty as provided herein beginning with the date of the original purchase at retail, and no warranties, whether express or implied, shall apply to this product thereafter. Some states do not allow limitations on implied warranties, therefore these exclusions may not apply to you. This warranty gives you specific legal rights, and you may also have other rights which vary from state to state.

If you need service on your JL AUDIO product:

All warranty returns should be sent to JL AUDIO freight prepaid through an authorized JL AUDIO dealer and must be accompanied by proof of purchase (a copy of the original sales receipt.) Direct returns from consumers or non-authorized dealers will be refused unless specifically authorized by JL AUDIO with a valid return authorization number. Warranty expiration on products returned without proof of purchase will be determined from the manufacturing date code. Coverage may be invalidated as this date is previous to purchase date. Return only defective components. Non-defective items received will be returned freight-collect. Customer is responsible for shipping charges and insurance in sending the product to JL AUDIO. Freight damage on returns is not covered under warranty. Always include proof of purchase (sales receipt).

For Service Information in the U.S.A. please call:

JL Audio customer service: (954) 443-1100 during normal business hours (Eastern Time)

JL Audio, Inc

10369 North Commerce Parkway, Miramar, FL 33025

International Warranties:

Products purchased outside the United States of America are covered only by that country's distributor and not by JL Audio, Inc.

