

4. Product conformity information

4.1 FCC compliance

This device complies with part 15 of the FCC Rules. Operation is subject to the following two conditions: (1) This device may not cause harmful interference, and (2) This device must accept any interference received, including interference that may cause undesired operation.

This equipment has been tested and found to comply with the limits for a Class A digital device, pursuant to part 15 of the FCC Rules. These limits are designed to provide reasonable protection against harmful interference when the equipment is operated in a commercial environment.

This equipment generates, uses, and can radiate radio frequency energy and, if not installed and used in accordance with the instruction manual, may cause harmful interference to radio communications. Operation of this equipment in a residential area is likely to cause harmful interference in which case the user will be required to correct the interference at his own expense.

Changes or modifications not expressly approved by AvMap Satellite Navigation Inc. could void the user's authority to operate the equipment.

Compliance information statement

Identification of the product	Name	P/N
	SW BBFF CHIRP	UX0BBF20SE
Applicable compliance statements	This device complies with part 15 of the FCC Rules. Operation is subject to the following two conditions: (1) This device may not cause harmful interference, and (2) This device must accept any interference received, including interference that may cause undesired operation.	
Responsible party	Name	AvMap Satellite Navigation Inc.
	Address	25 Enterprise Zone Drive, Riverhead, NY 11901 USA
	Phone	+1-800-363-2627
	Website	www.avmap.us

4.2 EU declaration of conformity

This device complies with Directive 2014/30/EU and Directive 2014/35/EU.

The full text of the EU declaration of conformity is available at the following internet address:
eudeclaration.avmap.it



MMBF2SE0AE010

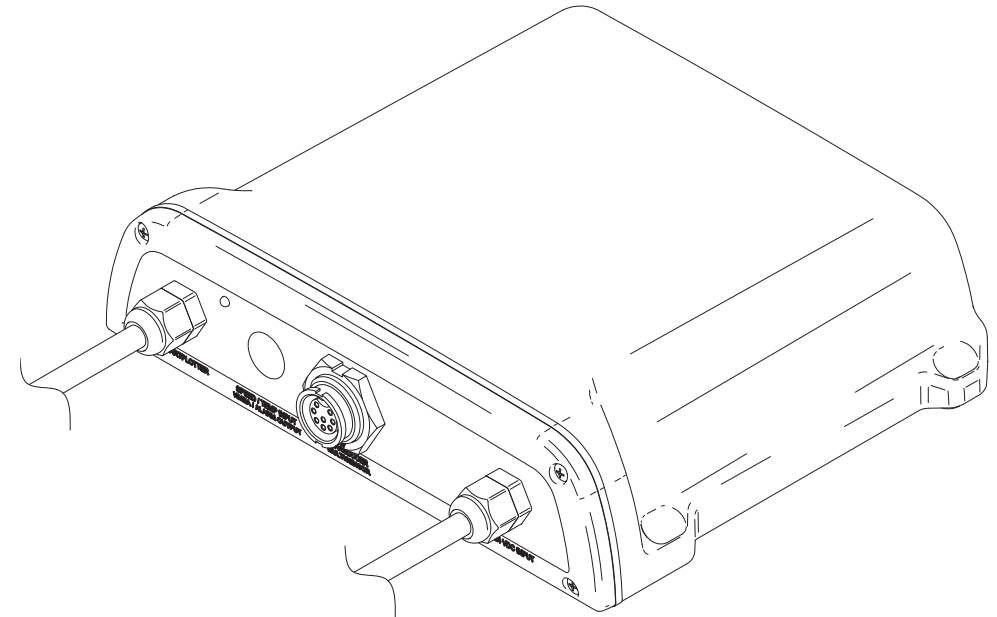

SW BBFF CHIRP

WARNING AND INSTALLATION MANUAL

1. Warranty and warnings

AvMap Srl warrants every unit to be free from defects in material and workmanship under normal use and service for a period of 24 months from original retail purchase. During the warranty period, **AvMap Srl** will repair or replace any component which fails in normal use without charges for parts or labour. Technological developments, modifications and upgrades of software are not covered by warranty. To receive warranty service, contact your local authorized dealer for shipping instructions. The device should be securely packed with its tracking code clearly written on the outside of the package, shipping to be paid by the customer. Include a copy of the original sales receipt as the proof of purchase. This limited warranty does not extend to any device which has been subjected to misuse, neglect, accident, incorrect wiring or improper installation. **AvMap Srl** reserves the right to either repair or replace the device at its sole discretion.

For more warranty information please see the web site: www.seiwadirect.com

For technical advice or assistance in Europe contact:

AvMap Srl

Viale Zaccagna 6, 54033 Carrara (MS), Italy

Customer support: +39-0585-784044

support@seiwadirect.com

	If water leaks into the equipment, immediately turn off the power at the switchboard. Fire or electrical shock can result.
	If the equipment is giving off smoke or fire, immediately turn off the power at the switchboard. Fire or electrical shock can result.
	Do not open the equipment. The equipment operates at high voltage that can cause electrical shock.
	Extensive exposure to heat may result in damage to the device.
	Please read the device manual before first operation. If you have any questions, please contact customer service or your local dealer.

Please, refer to the chart-plotter User manual for instructions on how to operate this Fish Finder device.

2. Technical Specifications

- Size: 196.4mm x 164.9mm x 50mm (7,73" x 6,49" x 1,9")
- Weight: 600 g
- Supply Voltage: 10-35 Vdc
- Transducer Frequency: CHIRP LF/MF/HF (40 to 210 kHz) | CW 50/200 kHz
- Transducer Power: From 300 W to 1 kW
- Compatible with Airmar CHIRP and CW transducers and Radarsonics CW transducers
- IPX6 Waterproof and shock resistant housing
- Operating temperature: -20°C / +60°C (-4°F / +140°F)
- Storage Temperature: -20°C / +70°C (-4°F / +158°F)

NOTE: Not compatible with Combo version (equipped with Built-in Fish Finder) of the 9" and 12" chart-plotters

NOTE: This device is compatible with chart-plotters with software version 5.0 or newer.

3. Connections scheme

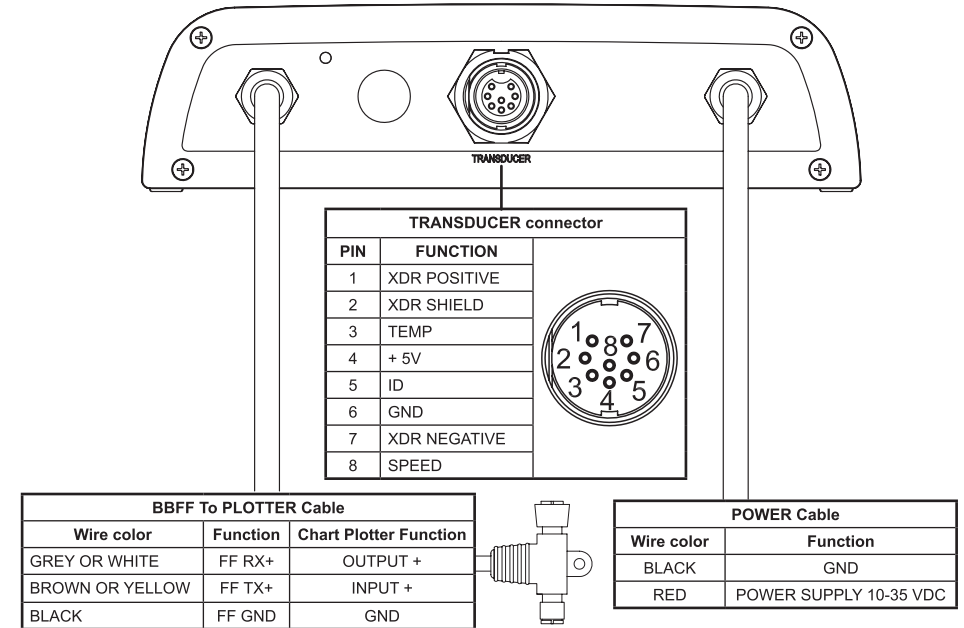

3.1 BBFF Chirp to chart-plotter connections

3.1.1 T-junction

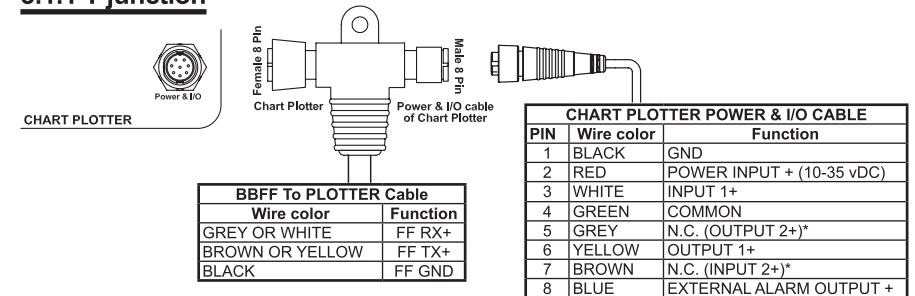

*If BBFF Chirp is connected, these wires cannot be used

3.1.2 Free wires

