

# SAILOR 7222 VHF DSC

## Installation manual



# SAILOR 7222 VHF DSC

## Installation manual

**Document number:** 98-171833-A

**Release date:** October 15, 2021

## **Disclaimer**

Any responsibility or liability for loss or damage in connection with the use of this product and the accompanying documentation is disclaimed by Thrane & Thrane A/S. The information in this manual is provided for information purposes only, is subject to change without notice and may contain errors or inaccuracies. Manuals issued by Thrane & Thrane A/S are periodically revised and updated. Anyone relying on this information should acquire the most current version e.g. from [www.cobhamsatcom.com](http://www.cobhamsatcom.com), **Cobham SYNC Partner Portal**, or from the distributor. Thrane & Thrane A/S is not responsible for the content or accuracy of any translations or reproductions, in whole or in part, of this manual from any other source. In the event of any discrepancies, the English version shall be the governing text.

Thrane & Thrane A/S is trading as Cobham SATCOM.

## **Copyright**

© 2021 Thrane & Thrane A/S. All rights reserved.

## **Manufacturer address**

Thrane & Thrane A/S, Lundtoftegårdsvej 93D, DK-2800, Kgs. Lyngby, Denmark

## **Trademark acknowledgments**

- SAILOR is a registered trademark of Thrane & Thrane A/S.
- Other product and company names mentioned in this manual may be trademarks or trade names of their respective owners.

# Table of contents

---

<b>Chapter 1</b>	<b>Introduction</b>	
	1.1 VHF radio with DSC Class A .....	1-1
	1.2 Accessories available .....	1-3
	1.3 System configuration - example .....	1-5
<b>Chapter 2</b>	<b>Installation</b>	
	2.1 Unpacking and initial inspection .....	2-1
	2.2 Installing the VHF radio .....	2-2
	2.3 Connectors on the SAILOR 7224 Control Unit .....	2-10
	2.4 Connectors on SAILOR 7226 VHF Transceiver Unit .....	2-18
	2.5 VHF and DSC antenna installation .....	2-21
	2.6 Wiring of connection boxes .....	2-23
	2.7 Connect the Control Unit to the Transceiver Unit .....	2-28
<b>Chapter 3</b>	<b>First-time power up</b>	
	3.1 General use and navigation .....	3-1
	3.2 Entering the MMSI number .....	3-2
	3.3 Forced low power AUX input control .....	3-3
<b>Chapter 4</b>	<b>Configuration</b>	
	4.1 Administrator access .....	4-1
	4.2 SETTINGS .....	4-2
<b>Chapter 5</b>	<b>Service &amp; maintenance</b>	
	5.1 Contact for support .....	5-1
	5.2 Software update .....	5-1
	5.3 Alerts in the Bridge Alert Management system (BAM) .....	5-4
	5.4 DSC self test .....	5-4
	5.5 Maintenance .....	5-5
	5.6 Returning units for repair .....	5-6
<b>Appendix A</b>	<b>Specifications</b>	
	A.1 SAILOR 7226 VHF Transceiver Unit .....	A-1
	A.2 SAILOR 7224 Control Unit .....	A-3
	A.3 General DSC specifications .....	A-4
	A.4 NMEA specifications .....	A-4

<b>Appendix B</b>	<b>NMEA sentences</b>	
B.1	NMEA sentences used .....	B-1
B.2	Sentence use reference .....	B-4
<b>Appendix C</b>	<b>System configurations</b>	
C.1	System configuration examples .....	C-1
C.2	Cable requirements .....	C-17
<b>Glossary</b>	.....	Glossary-1
<b>Index</b>	.....	Index-1

# List of figures

---

## Chapter 1 Introduction

- Figure 1-1: Controls on the front plate of the Control Unit..... 1-2
- Figure 1-2: System configuration, example ..... 1-5

## Chapter 2 Installation

- Figure 2-1: Control Unit, Desktop mounting 1/2 ..... 2-3
- Figure 2-2: Control Unit, Overhead mounting ..... 2-4
- Figure 2-3: Control Unit, Mounting with the mounting bracket ..... 2-5
- Figure 2-4: Control Unit, Drilling plan for the mounting bracket ..... 2-5
- Figure 2-5: SAILOR 7224 Control Unit Dimensions for flush mount..... 2-6
- Figure 2-6: Control Unit, Cutout for flush mount..... 2-6
- Figure 2-7: Control Unit, Flush mount ..... 2-7
- Figure 2-8: Transceiver Unit, dimensions ..... 2-8
- Figure 2-9: SAILOR 6201 Handset with cradle, dimensions for mounting..... 2-9
- Figure 2-10: SAILOR 7224 Control Unit, rear panel connectors..... 2-10
- Figure 2-11: SAILOR 7226 VHF Transceiver Unit, connectors ..... 2-18
- Figure 2-12: Transceiver Unit, remove cover ..... 2-19
- Figure 2-13: Transceiver Unit, connect power cables..... 2-19
- Figure 2-14: Antenna positioning 1/2..... 2-22
- Figure 2-15: Antenna positioning, 2/2..... 2-22
- Figure 2-16: SAILOR 6207 Connection Box for parallel handsets, mounting ..... 2-23
- Figure 2-17: SAILOR 6207 Connection Box for parallel handsets, wiring..... 2-23
- Figure 2-18: SAILOR 6207 Connection Box for parallel handsets, diagram..... 2-24
- Figure 2-19: SAILOR 6208 Control Unit Connection Box, mounting..... 2-25
- Figure 2-20: SAILOR 6208 Control Unit Connection Box for parallel handsets, wiring .. 2-25
- Figure 2-21: SAILOR 6208 Control Unit Connection Box, diagram ..... 2-26
- Figure 2-22: SAILOR 6209 Accessory Connection Box, mounting ..... 2-27
- Figure 2-23: SAILOR 6209 Accessory Connection Box, wiring ..... 2-27
- Figure 2-24: SAILOR 6209 Accessory Connection Box, diagram..... 2-28

## Chapter 3 First-time power up

## Chapter 4 Configuration

- Figure 4-1: SETTINGS menu tree ..... 4-3

## Chapter 5 Service & maintenance

- Figure 5-1: Fuse in Transceiver Unit ..... 5-5

## Appendix A Specifications

- Figure A-1: NMEA interface description.....A-5

## Appendix B NMEA sentences

## Appendix C System configurations

Figure C-1: System configuration, SAILOR N163S Power Supply .....	C-2
Figure C-2: System configuration, SAILOR 6201, GNSS, ext. loudspeaker and alarms..	C-3
Figure C-3: System configuration, GNSS and SAILOR 6270 External loudspeaker .....	C-4
Figure C-4: System configurations, 2 SAILOR 6201 Handsets and a GNSS.....	C-5
Figure C-5: System configuration, CAN bus, SAILOR 6204 CSM, close to the VHF radio	C-6
Figure C-6: System configuration, CAN bus, SAILOR 6204 CSM, not close to the VHF radio	C-7
Figure C-7: System configuration, CAN bus, SAILOR 6204 CSM, far from the VHF radio	C-8
Figure C-8: System configuration: CAN bus, 2 SAILOR 6204 CSMs, far from VHF radio.	C-9
Figure C-9: System configuration: CAN bus, 2 SAILOR 6204 CSMs, close VHF, small bridge	C-10
Figure C-10: System configuration: CAN bus, 2 SAILOR 6204 CSMs, in bridge wings.....	C-11
Figure C-11: System configuration: CAN bus, 3 SAILOR 6204 CSMs.....	C-12
Figure C-12: System configuration: CAN bus, 4 SAILOR 6204 CSMs.....	C-13
Figure C-13: System configuration: Installation of LAN.....	C-14
Figure C-14: System configuration: Installation of Central Alert Management (CAM)...	C-15
Figure C-15: System configuration: Installation of a printer.....	C-16

# List of tables

---

## Chapter 1 Introduction

Table 1-1: Accessories.....	1-3
-----------------------------	-----

## Chapter 2 Installation

Table 2-1: Compass safe distance.....	2-3
Table 2-2: Pin allocation, ACC connector.....	2-11
Table 2-3: Pin allocation, AUX connector.....	2-12
Table 2-4: Pin allocation, OPT connector.....	2-13
Table 2-5: Pin allocation, CTRL connector.....	2-14
Table 2-6: Pin allocation, LAN connectors on Control Unit.....	2-15
Table 2-7: Pin allocation, USB connector.....	2-16
Table 2-8: Pin allocation, power.....	2-17
Table 2-9: Pin allocation, LAN connectors on Transceiver Unit.....	2-20

## Chapter 3 First-time power up

## Chapter 4 Configuration

Table 4-1: SETTINGS > RADIO menu.....	4-4
Table 4-2: SETTINGS > CONTROLLER menu.....	4-5
Table 4-3: SETTINGS > CHANNELS menu.....	4-5
Table 4-4: SETTINGS > CHANNELS, channel properties.....	4-6
Table 4-5: Explanation of channel properties.....	4-7
Table 4-6: SETTINGS > DSC menu.....	4-8
Table 4-7: SETTINGS > POWER SUPPLY menu.....	4-10
Table 4-8: SETTINGS > NMEA menu.....	4-10
Table 4-9: SETTINGS > NETWORK menu.....	4-11
Table 4-10: SETTINGS > SYSTEM menu.....	4-12
Table 4-11: SETTINGS > REMOTE CONTROL.....	4-13
Table 4-12: SETTINGS > ABOUT.....	4-14

## Chapter 5 Service & maintenance

## Appendix A Specifications

Table A-1: Transceiver Unit, general specifications.....	A-1
Table A-2: Transceiver Unit, detailed specifications.....	A-1
Table A-3: Control Unit specifications.....	A-3
Table A-4: General DSC specifications.....	A-4
Table A-5: NMEA specifications.....	A-4
Table A-6: List of alerts.....	A-6



## Appendix B NMEA sentences

Table B-1: Multicast addresses and ports for LWE transmission groups.....	B-1
Table B-2: Supported sentences.....	B-2
Table B-3: Other network functionality, input.....	B-3
Table B-4: Other network functionality, output.....	B-3
Table B-5: ACN - Alert command (input).....	B-4
Table B-6: ALC - Cyclic alert list (output).....	B-5
Table B-7: ALF - Alert sentence (output).....	B-5
Table B-8: ARC sentence - Alert Command Refused.....	B-6
Table B-9: GGA sentence - Global positioning system (GPS) fix data.....	B-6
Table B-10: GLL sentence - Geographic position (output).....	B-7
Table B-11: GNS sentence - Fix data (input).....	B-7
Table B-12: HBT sentence - Heartbeat supervision sentence (input).....	B-8
Table B-13: RMC sentence - Recommended minimum specific GNSS data (input).....	B-8
Table B-14: ZDA sentence - Time and Date (output).....	B-9

## Appendix C System configurations

Table C-1: Cable overview.....	C-17
Table C-2: Cable specifications for cable 2.....	C-18
Table C-3: Pin allocation, power to Control Unit.....	C-19
Table C-4: Cable specifications for cable 5.....	C-19
Table C-5: Cable specifications for cable 8 (AUX).....	C-20
Table C-6: Cable specifications for cable 8 (CTRL).....	C-22
Table C-7: Pin allocation, LAN connector.....	C-23

# Introduction

## 1.1 VHF radio with DSC Class A

Exceeding standards set by IMO regulation for GMDSS Class A VHF, the August 2021-introduced Bridge Alert Management IMO resolution MSC.302(87), as well as IEC 62923-1 & IEC 62923-2, the SAILOR 7222 VHF DSC Class A is a robust platform for when clear communication could make the difference between a non-event and a major incident.



As part of the required safety equipment, use the SAILOR 7222 VHF DSC in an emergency situation. However the best way to guarantee functionality in an emergency situation, is to use the radio in daily communication on board.

The VHF radio is a simplex/semi duplex VHF radio consisting of two units connected with a standard Ethernet cable:

- SAILOR 7224 Control Unit
- SAILOR 7226 VHF Transceiver Unit

It is designed with an easy-to-use menu-driven setup. You use the touch screen on the SAILOR 7224 Control Unit or a connected device with a browser to enter the desired functions. You can also select channels using the rightmost selection knob. The large display can be customized for optimum readability and visibility both day and night with different color themes.

The VHF radio can replay 480 seconds of received voice messages. This is a useful feature to minimize misunderstandings and to record messages when the radio is unattended.

With SAILOR connection boxes the VHF radio connects easily to external equipment like a BAM system, additional handsets, water proof hand microphones, control speaker microphone, alarm panel or external speaker. The Ethernet interface connects the Control Unit with the Transceiver Unit, and enables the VHF radio to be connected to other units in a local network. Instead of the touch screen on the Control Unit, you can also connect a PC or other device with a browser for setup and control via the web interface.

For a list of accessories available for the VHF radio see *Accessories available* on page 1-3 and check with your nearest distributor.

### 1.1.1 Controls on the front plate of the Control Unit

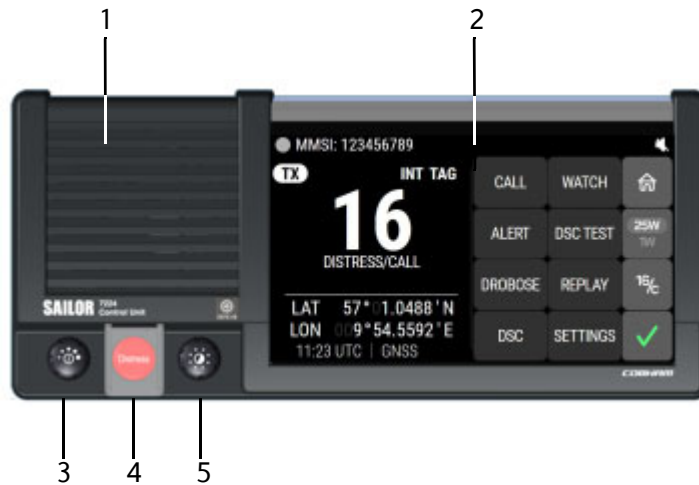

Figure 1-1: Controls on the front plate of the Control Unit

1. Loudspeaker.
2. Large 5.5" TFT display with capacitive multi touch.
3. Volume control, on/off and Squelch control.
4. Distress button for sending a Distress alert.
5. Channel selector and dim knob with push-function to switch between channel selection and dimming.

### 1.1.2 SAILOR 7222 VHF DSC display

The picture shows the display after start-up. The display holds various fields of information, depending on the currently selected function.

1. UTC time.
2. MMSI number.
3. Position information (latitude and longitude).
4. Current working channel.  
Tap to get an on-screen keyboard for changing the working channel.
5. Current communication direction: Rx (receive) or Tx (transmit).
6. Service line containing current temporary information relevant for the current channel or function.
7. On-screen key functions.
8. Channel properties of the currently selected VHF channel (if any).

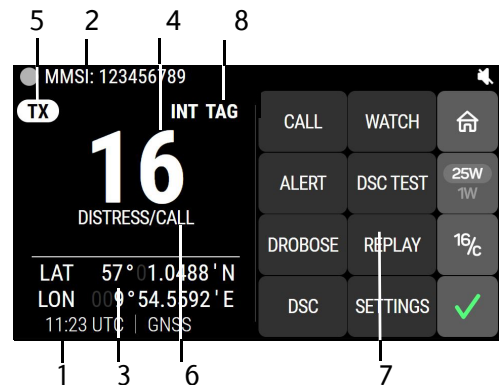

For a description of the information shown for each of the functions available see the user manual for the SAILOR 7222 VHF DSC.

For a detailed description of the SETTINGS menu functions, see *Configuration* on page 4-1.

## 1.2 Accessories available

Part number	Description	
406201A-00500	SAILOR 6201 Handset with cradle (additional)	
406203A-00500	SAILOR 6203 Handset with cradle, waterproof to IPx6.	
406202A-00500	You can use the SAILOR 6202 Hand Microphone (waterproof to IPx6 and IPx8) instead of the handset.	
406204A-00500	With the SAILOR 6204 Control Speaker Microphone (CSM) you can control the VHF voice functions of the SAILOR 7222 VHF DSC.	
406207A-00500	The SAILOR 6207 Connection Box for parallel Handsets including Connection Cable 406209-941 is used for easy installation of several SAILOR 6201/SAILOR 6203 Handsets.	
406208A-00500	SAILOR 6208 Control Unit Connection Box including Connection Cable 406208-941 is used for easy installation of external equipment and accessories: <ul style="list-style-type: none"> <li>• Max. 4 SAILOR 6204 Control Speaker Microphones</li> <li>• VDR</li> <li>• SAILOR 6270 External Loudspeaker</li> <li>• Alarm panels and GNSS input</li> </ul>	
406209A	SAILOR 6209 Accessory Connection Box is used to connect the OPT connector on the Control Unit to a Bridge Alert Management unit (BAM).	
407224A-930	U-Mount Bracket Kit: Used for desktop or overhead mounting of the SAILOR 7224 Control Unit.	
407224A-950	Flush Mount Bracket Kit: Used for flush mounting the SAILOR 7224 Control Unit, e.g. in an instrument panel.	

Table 1-1: Accessories





Part number	Description
	<p><b>Cables:</b></p> <p>406209-940 <b>5m connection cable for bulk mount, 1x10 pole:</b> Use this cable to connect a handset to a SAILOR 6207 or SAILOR 6209 Connection Box in installations where the handset is not connected directly to the SAILOR 7222 VHF DSC, but located in a different position.</p> <p>406209-941 <b>5m connection cable, 1x10 pole:</b> Use this cable to connect the Control Unit to a SAILOR 6207 or SAILOR 6209 Connection Box in installations where the handset is not connected directly to the SAILOR 7222 VHF DSC, but located in a different position.</p> <p>406208-941 <b>5m connection cable, 1x12 pole:</b> Use this cable to connect the Control Unit to a SAILOR 6208 Connection Box.</p> <p>406204-940 <b>5m connection cable, 1x12 pole:</b> Use this cable to connect a SAILOR 6204 Control Speaker Microphone to a SAILOR 6208 Connection Box.</p> <p>407224A-980 <b>5m cable., RJ45:</b> Use this cable to connect the SAILOR 7224 Control Unit to the SAILOR 7226 VHF Transceiver Unit.</p> <p>407224A-990 <b>Cable for Bulk Head Mounting - Handset, 10 pole:</b> Use this cable for connecting the Control Unit to a wall plug for a bulkhead mounted handset.</p>
406270A	<p>If you need an additional external loudspeaker you can connect a SAILOR 6270 External Loudspeaker.</p> 
406103A-00500	<p>With the SAILOR 6103 Multi Alarm Panel you can activate GMDSS Distress Alarms. The Multi Alarm Panel can be connected to the SAILOR 7222 VHF DSC via the Ethernet interface (LAN connector).</p> 
406197A-00500	<p>The SAILOR 6197 Ethernet Switch is used in installations with SAILOR 6103 Multi Alarm Panels and in installations with a local network. The Ethernet switch has 5 ports.</p> 
80119410	<p>The N163S Power supply provides 24 VDC for the SAILOR 7222 VHF DSC.</p> 

Table 1-1: Accessories (Continued)

## 1.3 System configuration - example

The SAILOR 7222 VHF DSC can be customized to suit your installation. The following illustration is one example of a system. For further configuration examples see Appendix B, System configurations.

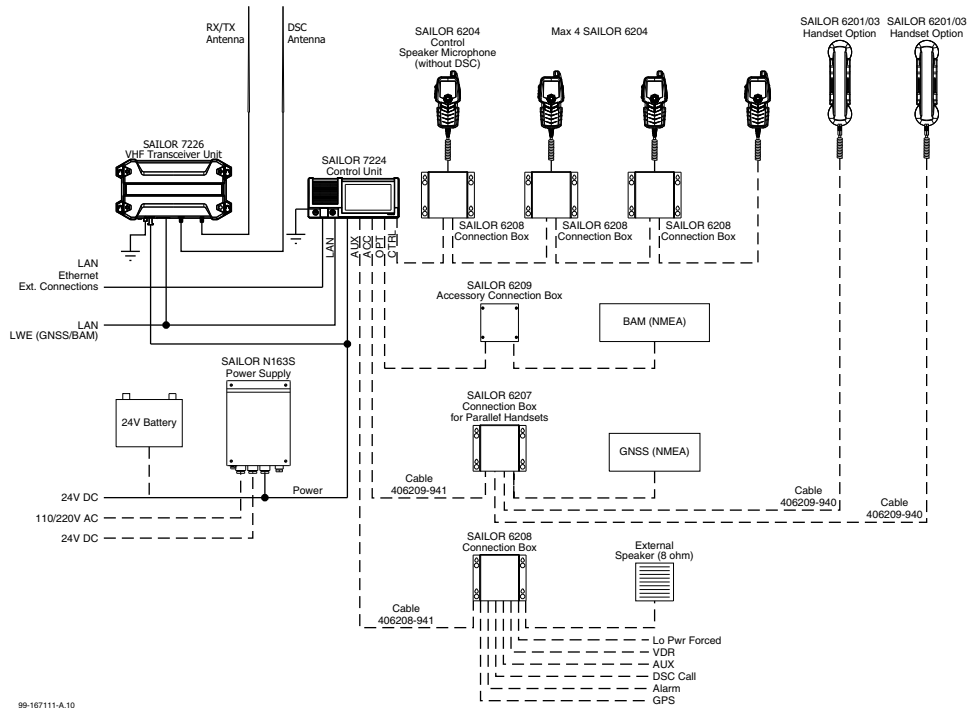

Figure 1-2: System configuration, example

## Installation

In this chapter you find information and guidelines for:

- *Unpacking and initial inspection*
- *Installing the VHF radio*
- *Connectors on the SAILOR 7224 Control Unit*
- *Connectors on SAILOR 7226 VHF Transceiver Unit*
- *VHF and DSC antenna installation*
- *Wiring of connection boxes*

### 2.1 Unpacking and initial inspection

The following items are included in the delivery of a SAILOR 7222 VHF DSC:

- SAILOR 7224 Control Unit
  - Cable Relief Kit, SAILOR 72xx CU
  - Installation guide for Control Unit
- SAILOR 7226 VHF Transceiver Unit
  - Screw kit for SAILOR 7226 VHF Transceiver Unit
  - Installation guide for Transceiver Unit
- SAILOR 6201 Handset with cradle
  - Screw kit for cradle
  - Installation guide for handset and cradle
- User manual
- DC Power cable

## 2.1.1 Initial inspection

Inspect the shipping carton immediately upon receipt for evidence of damage during transport. If the shipping carton is severely damaged or water stained, request that the carrier's agent be present when opening the carton. Save the carton packing material for future use.



**WARNING!** To avoid electric shock, do not apply power to the system if there is any sign of shipping damage to any part of the front or rear panel or the outer cover. Read the safety summary at the front of this manual before installing or operating the system.

After unpacking the system, inspect it thoroughly for hidden damage and loose components or fittings. If the contents are incomplete, if there is mechanical damage or defect, or if the system does not work properly, notify your dealer.

## 2.2 Installing the VHF radio

### 2.2.1 General requirements

The SAILOR 7222 VHF DSC radio consists of two units:

- SAILOR 7224 Control Unit, which controls the system and contains the user interface. It also connects to other units and systems (handsets, GNSS, BAM etc.).
- SAILOR 7226 VHF Transceiver Unit, which connects to the antenna(s) and via Ethernet to the Control Unit.

**Control Unit:** You can mount the SAILOR 7224 Control Unit as a desktop, overhead or flush-mounted unit integrated in the instrument panel.

- Provide space enough to access the front panel connectors and for installing a cradle for the speaking device.
- Provide **at least 120 mm space at the back** of the SAILOR 7222 VHF DSC radio to allow free air circulation and for cable access.

**Transceiver Unit:** You can mount the SAILOR 7226 VHF Transceiver Unit integrated in a SAILOR GMDSS Console or on a bulkhead using the screw kit included in the delivery.

### Cable requirements

All cables attached to the SAILOR 7222 VHF DSC must be shielded. Every shield should have a low impedance connection to an electrical ground.

Before using the SAILOR 7222 VHF DSC for the first time, check that all cables are correctly wired and fastened.

For details on the individual cable requirements, see *Cable requirements* on page C-17.



## Compass safe distance

Make sure that the SAILOR 7224 Control Unit and the SAILOR 7226 VHF Transceiver Unit are far enough from any magnetic compass to avoid influence of the loudspeaker magnet on the compass reading. See the following table for the safe distance after magnetization between the nearest point of the device and the center of the compass at which it will produce a deviation of 0.3°.

Device	Compass safe distance
SAILOR 7224 Control Unit	0.85 m
SAILOR 7226 VHF Transceiver Unit	0.55 m
SAILOR 6201 and 6203 Handset with cradle	0.95 m
SAILOR 6207 Connection Box for parallel handsets	0.45 m
SAILOR 6208 Control Unit Connection Box	0.45 m
SAILOR 6209 Accessory Connection Box	0.45 m

Table 2-1: Compass safe distance

## 2.2.2 SAILOR 7224 Control Unit with U mounting bracket

The U-Mount Bracket Kit (407224A-930) is available as an accessory from Cobham SATCOM.

### Desktop mounting

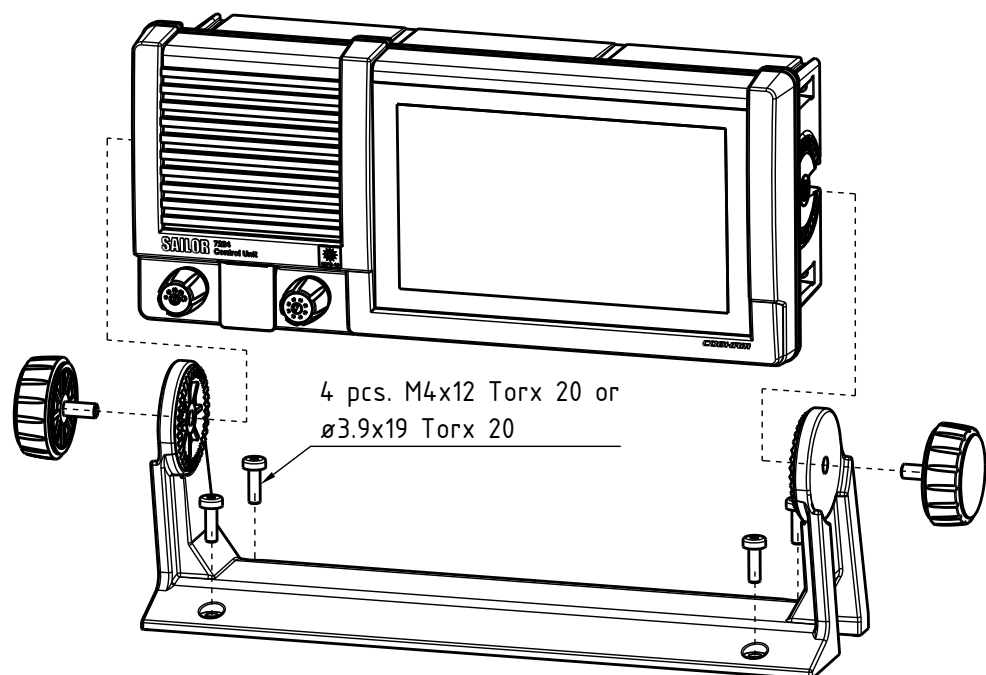

Figure 2-1: Control Unit, Desktop mounting 1/2

## Overhead mounting

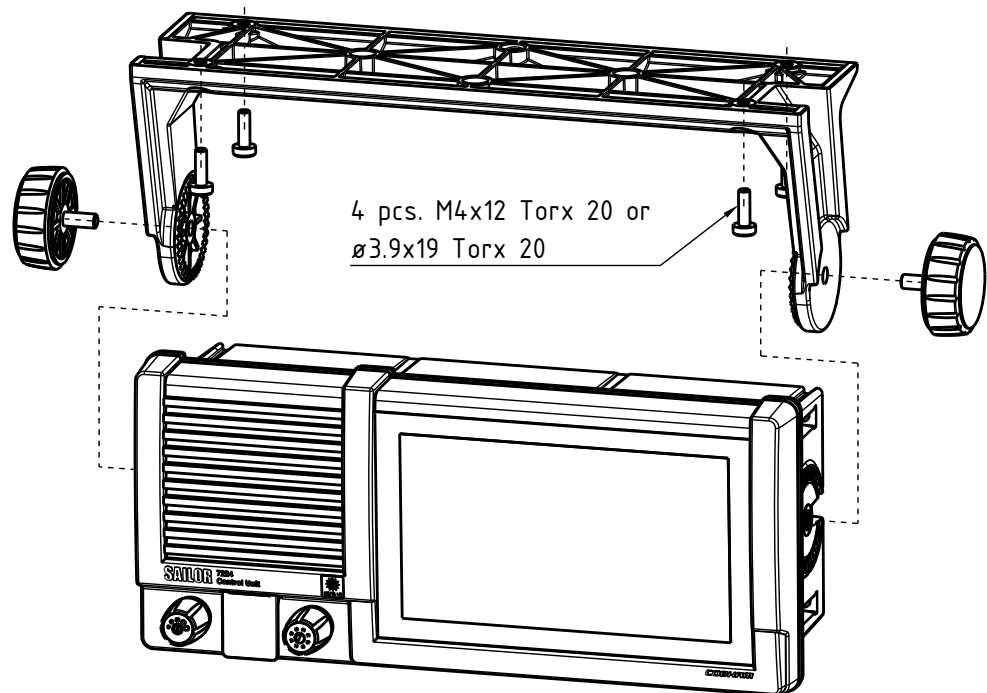

Figure 2-2: Control Unit, Overhead mounting

## Mounting with U mounting bracket

To mount the Control Unit, do as follows:

1. Find a suitable location for the Control Unit. Check that the space is wide/deep enough to accommodate the Control Unit.
2. Fasten the bracket with 4 screws (included in the delivery).
3. Insert the Control Unit in the bracket and fasten it with the two knobs.

- The display of the Control Unit should be at an angle of approximately 90° to your line of sight when operating it.

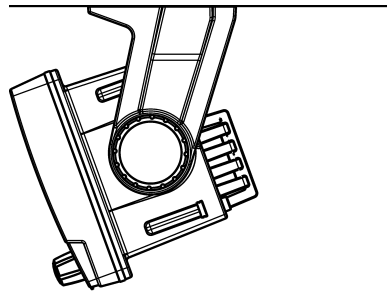

Tilting  $\pm 20^\circ$

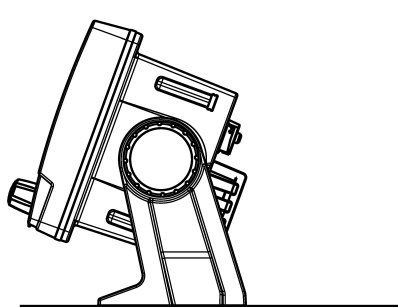

Figure 2-3: Control Unit, Mounting with the mounting bracket

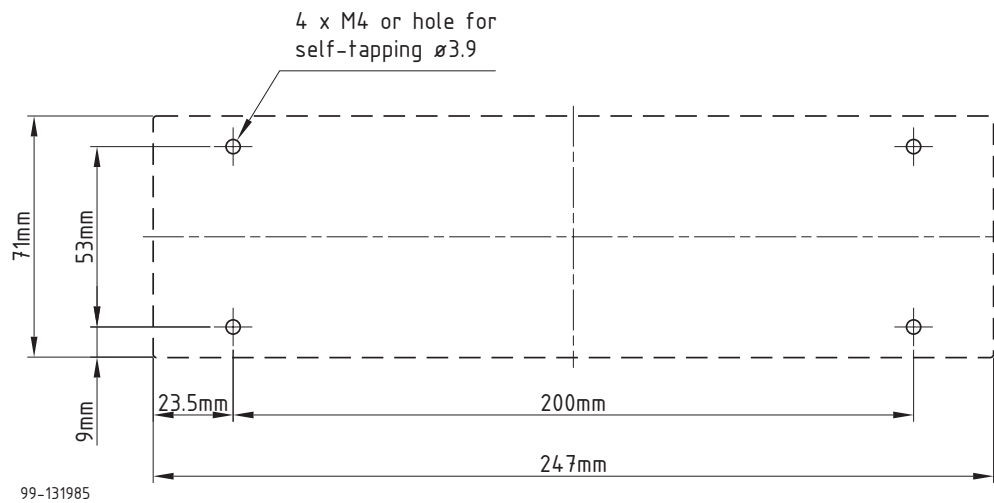

Figure 2-4: Control Unit, Drilling plan for the mounting bracket

## 2.2.3 SAILOR 7224 Control Unit for flush mount

You can mount the Control Unit to a flat surface, e.g. an instrument panel. The Flush Mount Bracket Kit (407224A-950) is available as an accessory from Cobham SATCOM.

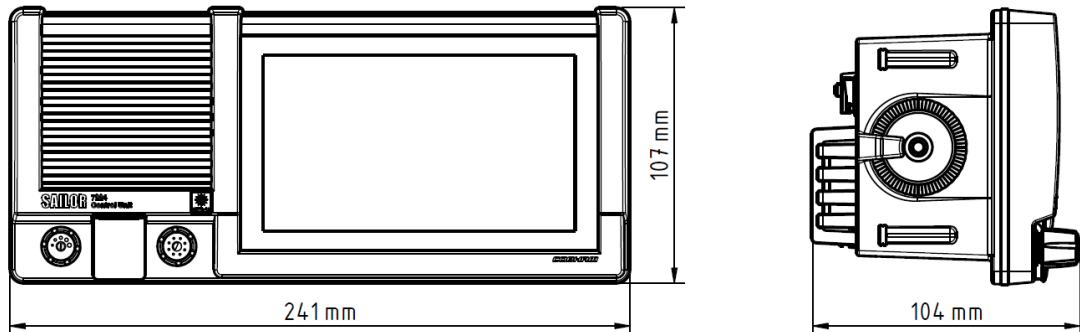

Figure 2-5: SAILOR 7224 Control Unit Dimensions for flush mount

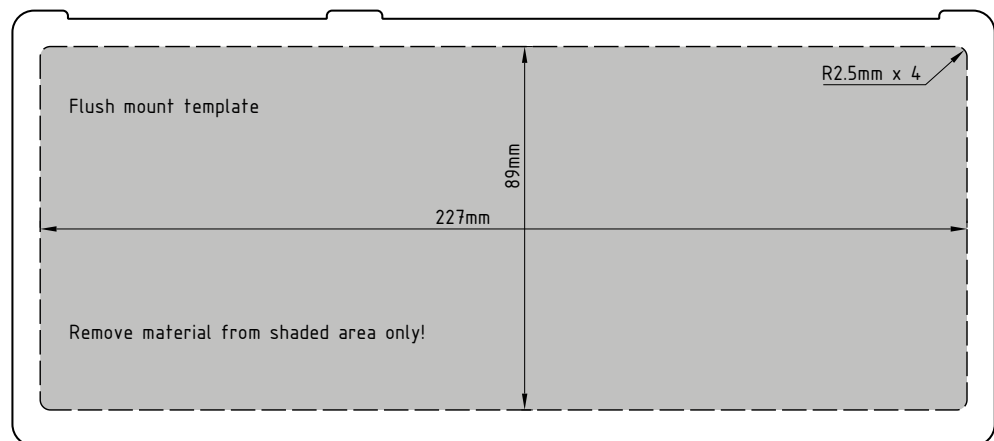

Figure 2-6: Control Unit, Cutout for flush mount

**Important** The scaling in the above drawing is not 1:1. Consequently do not attempt to use a print or copy of this page without checking the dimensions.

1. Find a suitable location for the Control Unit. Check that the space is deep enough to accommodate the Control Unit and an additional min. 120 mm space for cable entry.
2. Keep free distance to allow free air circulation around the Control Unit and to allow sufficient space for access to cables, see the drawing on this page.
3. Cut out the hole for the Control Unit where you want to mount it. Use the cutting template in the installation guide.
4. Mount the 4 square nuts M4 in the cabinet, ensure that they are placed correctly so it is possible to screw in the M4x45 screws.
5. Ensure that the flush mount gasket is placed correctly on the Control Unit.

6. Before mounting the Control Unit be aware that the surface is plane and rigid. If the surface is not plane and/or rigid (stiff) remove the gasket and seal with silicone sealant between the Control Unit and the surface.
7. Slide the Control Unit in the cut-out. Place the flush mount bracket and fasten it with the 4 screws M4x45. Make sure the torque does not exceed 1Nm when fastening the screws.

**Note** Only use screws supplied with the kit for flush mounting.

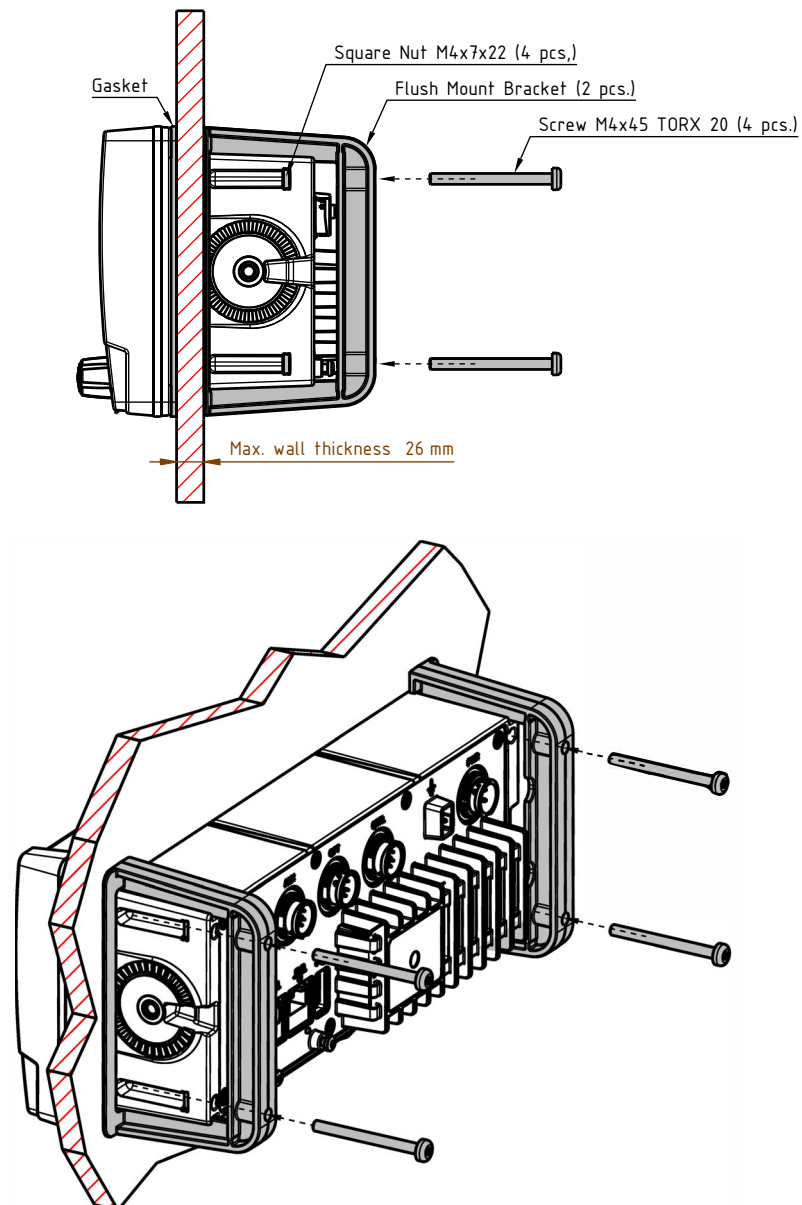

Figure 2-7: Control Unit, Flush mount

**Note** Firmly tie back and secure any wires not used to avoid the possibility for mutual shorting or shorting to ground.

## 2.2.4 SAILOR 7226 VHF Transceiver Unit

You can install the Transceiver Unit integrated in a SAILOR GMDSS Console or on a bulkhead. A screw kit is included with the Transceiver Unit.

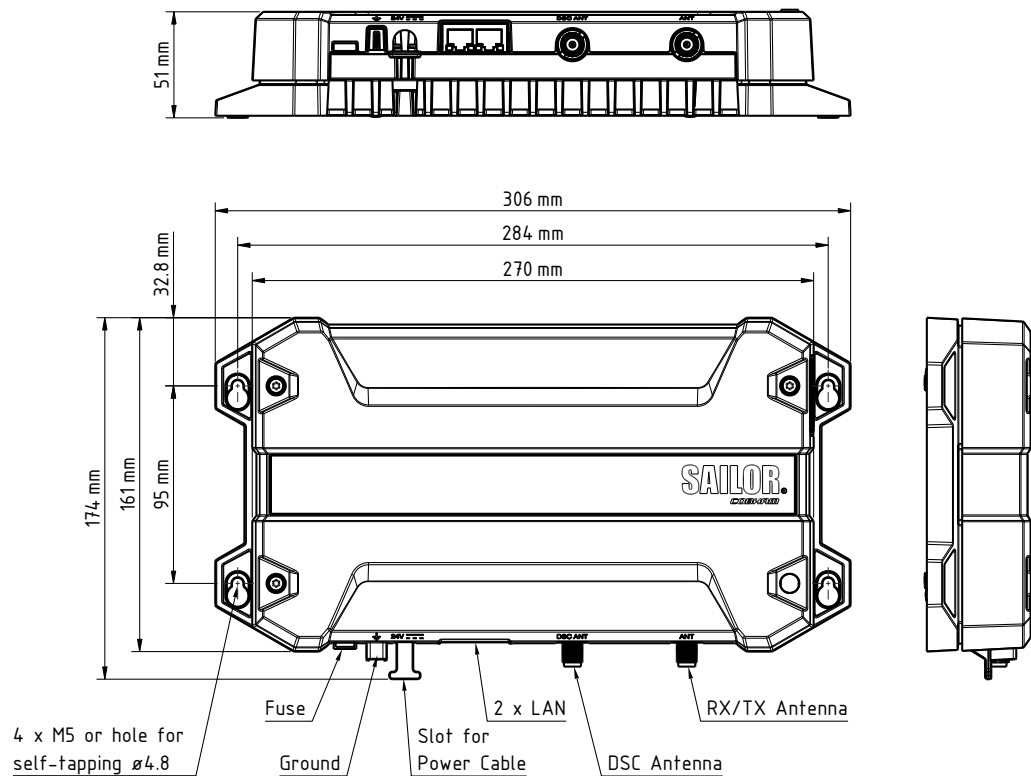

Figure 2-8: Transceiver Unit, dimensions

1. Find a suitable location for the Transceiver Unit, where the cables to antenna(s) and Control Unit can be placed appropriately.

**Note** | The Ethernet cable between Transceiver Unit and Control Unit must be no longer than **50 m**.

Keep free distance to allow free air circulation around the Transceiver Unit and to allow sufficient space for access to cables.

2. Place the Transceiver Unit as close as possible to ship ground.
3. Before mounting the Transceiver Unit be aware that the surface is plane and rigid.
4. Mount the 4 screws in the cabinet, ensure that they are placed correctly according to the dimensions in Figure 2-8.

## 2.2.5 SAILOR 6201 Handset with cradle

Install the cradle on a bulkhead according to the drawing below.

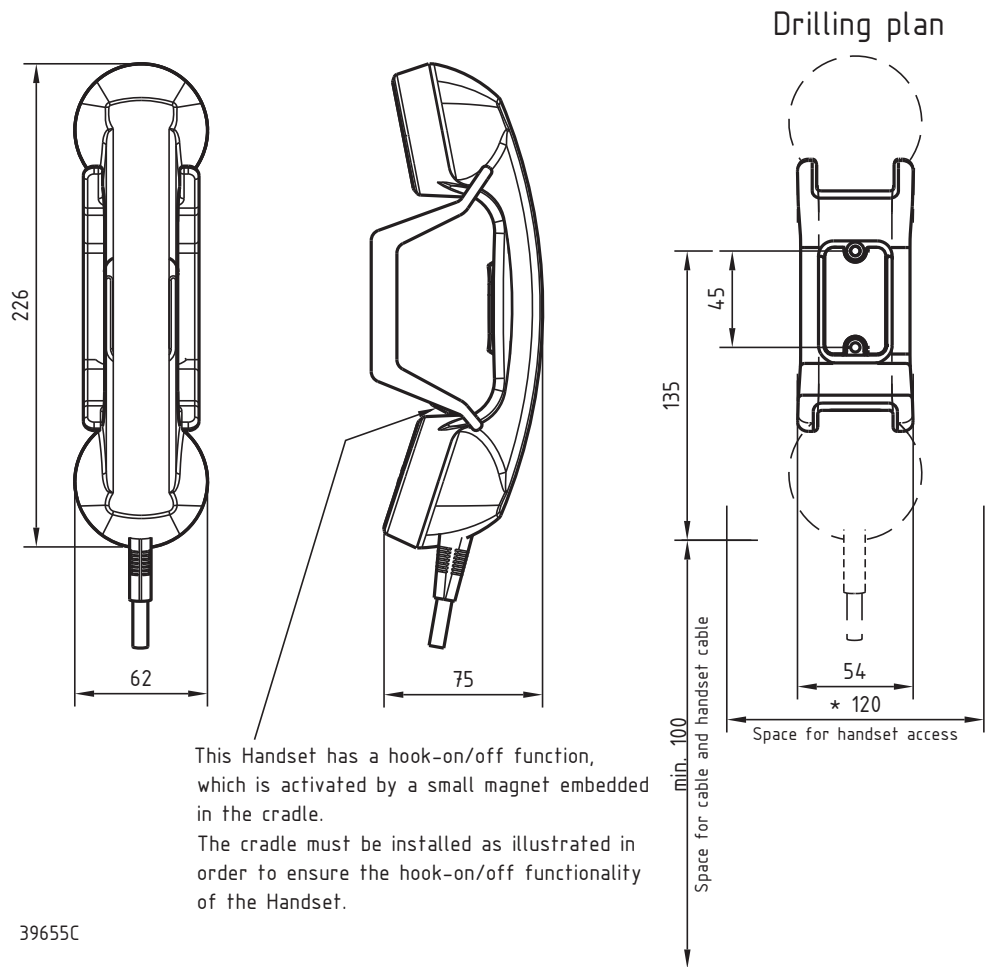

Figure 2-9: SAILOR 6201 Handset with cradle, dimensions for mounting.

## 2.3 Connectors on the SAILOR 7224 Control Unit

### 2.3.1 Connector overview SAILOR 7224 Control Unit

The Control Unit has the following connectors:

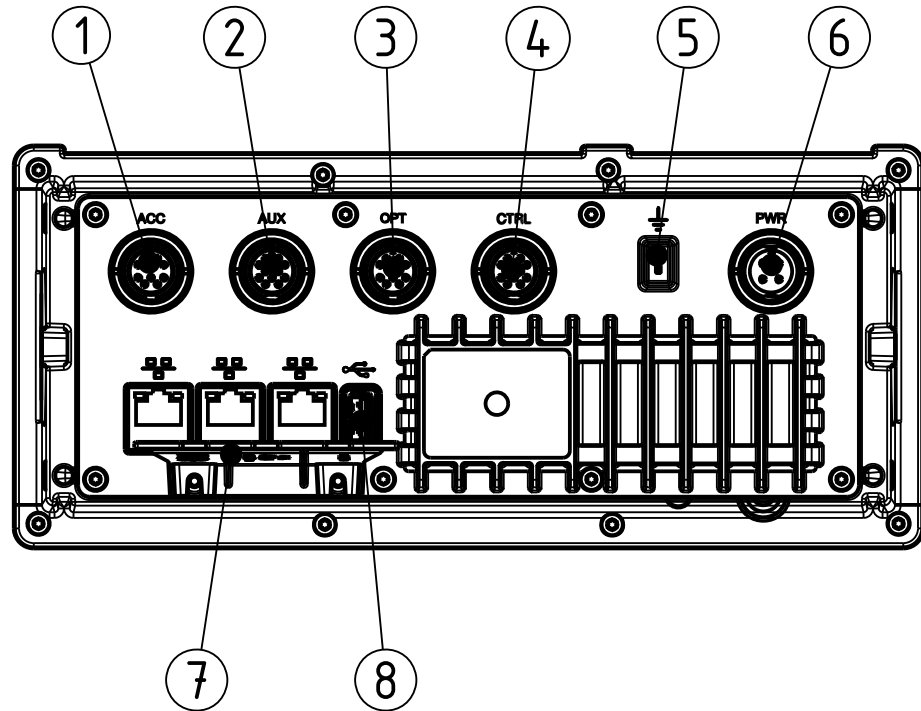

Figure 2-10: SAILOR 7224 Control Unit, rear panel connectors

1. *ACC connector* for accessories
2. *AUX connector* for VDR, external speaker, alarm panels, GNSS input
3. *OPT connector*
4. *CTRL connector*
5. *Cable shoe for grounding*
6. *Power connector*
7. *3 Ethernet connectors: LAN*
8. *USB connector*



## 2.3.2 ACC connector

Use the connector marked **ACC** to connect GNSS and a SAILOR 6201 Handset. You may also connect a waterproof SAILOR 6203 Handset or SAILOR 6202 Hand microphone.

**Connector type:** Circular connector, 10-pin, male.

Panel lock, 10 pin male

**Connection cable** with plug, part number 406209-941.

**Pin assignment:** Connector front view on the Control Unit.

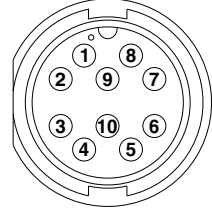

Pin	Description	Wire color
1	NMEA 1 in+	Brown
2	NMEA 1 in-	Blue
3	NMEA 2 in -	White
4	NMEA 2 in +	Green
5	Mike 2 / Line in	Yellow
6	EAR 2 / Line out	Grey
7	Hook_PTT	Pink
8	Battery supply when radio is on	Red
9	Internal GND = - Battery	Black
10	Internal GND = - Battery	Orange — SCREEN (Drain)

Table 2-2: Pin allocation, ACC connector

For details on the NMEA interface, see *NMEA specifications* on page A-4.

### 2.3.3 AUX connector

This connector is used to connect VDR, external speaker, DSC alarms and GNSS input.

**Connector type:** Circular connector, 12-pin.

**Connection cable** with plug, part number 406208-941.

**Pin assignment:** Connector front view on the Control Unit:

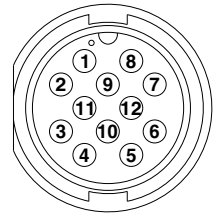

Pin	Description	Wire color
1	Shield (GND)	Brown
2	Lo Power Forced control	Blue
3	NMEA+ In	White
4	NMEA- In	Green
5	AUX OC	Yellow
6	DSC Call	Grey
7	DSC Alarm	Pink
8	-Battery	Red
9	External Speaker +	Black
10	External Speaker -	Orange
11	VDR+ Mixed RX/TX for record	Violet
12	VDR- Mixed RX/TX for record	Cyan

Table 2-3: Pin allocation, AUX connector

For details on the NMEA interface, see *NMEA specifications* on page A-4.

### 2.3.4 OPT connector

This connector is used for NMEA RX and TX for BAM support, e.g. via a Central Alert Management (CAM) system.

**Connector type:** Circular connector, 10-pin, male.

**Connection cable** with plug, part number 406209-941.

**Pin assignment:**

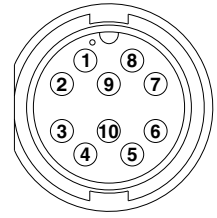

Panel lock, 10 pin male

Pin	Description	Wire color
1	NMEA in+	Brown
2	NMEA in-	Blue
3	NMEA out+	white
4	NMEA out-	green
5	NC	yellow
6	NC	gray
7	NC	pink
8	NC	red
9	GND	black
10	GND	orange
	Cable screen	-

Table 2-4: Pin allocation, OPT connector

For details on the NMEA interface, see *NMEA specifications* on page A-4.

### 2.3.5 CTRL connector

This connector is used to connect a SAILOR 6204 Control Speaker Microphone or SAILOR 6208 Connection Box.

**Connector type:** Circular connector, 12-pin.

**Connection cable** with plug, part number 406208-941.

**Pin assignment:** Connector front view on the Control Unit:

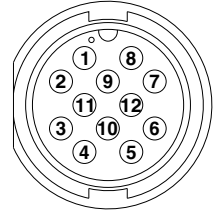

Pin	Description	Wire color
1	GND for cable screen	Brown
2	Internal GND-- Battery	Blue
3	Battery supply when radio is on	White
4	Battery supply when radio is on	Green
5	CAN+	Yellow
6	CAN-	Grey
7	Internal GND = - Battery	Pink
8	On/off from Control Speaker Microphone	Red
9	RX out +	Black
10	RX out -	Orange
11	TX in +	Violet
12	TX in -	Cyan

Table 2-5: Pin allocation, CTRL connector

## 2.3.6 Ethernet connectors: LAN

There are 3 Ethernet (10/100 MB) connectors on the rear panel:

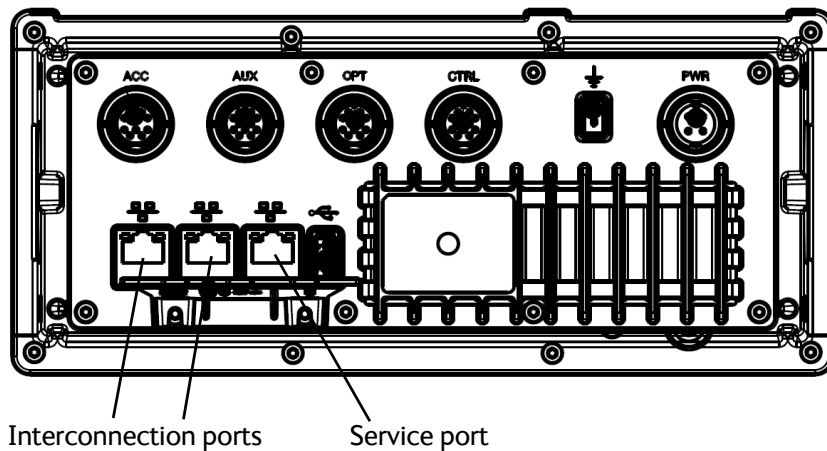

- Service port: The LAN connector next to the USB connector is used to access the SAILOR 7222 VHF DSC e.g. from external networks. The Service connector does not support RSTP.
- Interconnection ports: The two interconnection ports support RSTP and connect to the Transceiver Unit and to local network. They should **not** be connected to external networks.

Use one of the interconnection ports to connect to the Transceiver Unit.

**Note** | The Ethernet cable between Transceiver Unit and Control Unit must be no longer than **50 m**.

**Connector type:** RJ-45 female, shielded.

**Connection cable:** Shielded Ethernet cable, e.g. Cat. 6. Max 50 m.

**Pin assignment:**

Pin number	Pin function	Wire color
1	Tx+	white/orange
2	Tx-	orange
3	Rx+	white/green
4	Not connected	blue
5	Not connected	white/blue
6	Rx-	green
7	Not connected	white/brown
8	Not connected	brown

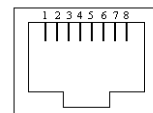

Table 2-6: Pin allocation, LAN connectors on Control Unit

## 2.3.7 USB connector

The SAILOR 7222 VHF DSC has a USB connector for connecting a USB memory device for updating the software or for saving or loading a configuration.

Update software and save/load configuration from the **SETTINGS** > **SYSTEM** menu, see *SYSTEM* on page 4-12.

**Connector type:** USB 2.0 Type A.

**Connection cable** Shielded USB cable.

**Pin assignment:**

Pin number	Pin function
1	VCC
2	D-
3	D+
4	GND



Table 2-7: Pin allocation, USB connector

## 2.3.8 Power connector

The DC Power input connects to a DC supply with 24 VDC nominal (-10% / +30%).

### Pin-out

The table below shows the connector outline, pin assignments and wire color in the power cable delivered with the SAILOR 7224 Control Unit.

Pin	Pin function	Wire color
1	DC+ (24 V DC +30% -10%)	Red
2	DC- (0 V DC)	Black
3	ON/OFF	White
4	NC	Blue
	Cable screen	-

Table 2-8: Pin allocation, power

### Connecting DC power



**CAUTION!** Make sure the power supply is off before connecting the power cable! The Control Unit is always on when connected to power.

- Connect DC+ (red wire) to DC out + from your DC supply.
- Connect DC- (black wire) to DC out - from your DC supply.
- Connect ON/OFF to Ground to switch on. If you are not using the on/off function, connect ON/OFF permanently to Ground.
- Connect the shield of the power cable to Ground.

## 2.3.9 Cable shoe for grounding

### Important

You must connect the cable shoe to ship ground.

The ground stud is located on the rear panel and is used to connect a ground wire for grounding the SAILOR 7224 Control Unit. To connect the Control Unit to ship ground, do as follows:

1. Connect a ground cable of < 1 m length and > 4 mm<sup>2</sup> cross section to the Ground cable shoe located next to the PWR connector.
2. Connect the other end of the cable to ship ground. Make the cable as short as possible.

## 2.4 Connectors on SAILOR 7226 VHF Transceiver Unit

### 2.4.1 Connector overview SAILOR 7226 VHF Transceiver Unit

The Transceiver Unit has the following connectors:

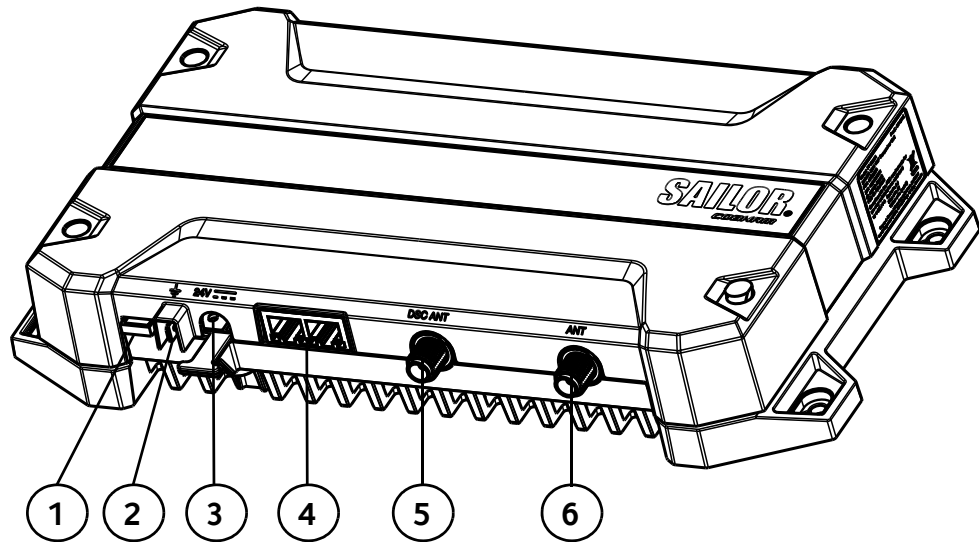

Figure 2-11: SAILOR 7226 VHF Transceiver Unit, connectors

1. Fuse
2. Ground
3. 24 VDC connection
4. 2 LAN connectors
5. DSC ANT connector for DSC antenna
6. ANT connector for VHF antenna

### 2.4.2 Fuse

The Transceiver Unit is protected by a 10 AT replaceable fuse, located next to the Ground connection.

### 2.4.3 Ground

1. Connect a ground cable of < 1 m length and > 4 mm<sup>2</sup> cross section to the Ground cable shoe located next to the PWR connector.
2. Connect the other end of the cable to ship ground. Make the cable as short as possible.



## 2.4.4 24 VDC connection

1. Remove the four Torx screws and take off the cover of the Transceiver Unit.

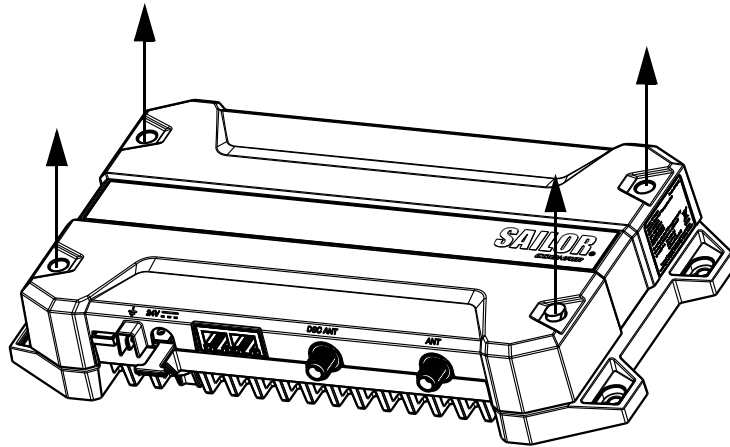

Figure 2-12: Transceiver Unit, remove cover



**CAUTION!** Make sure the power supply is off before connecting the power cable!

2. Connect the positive wire (red) to **+Vin** (closest to the fuse) and the negative wire (black) to **-Vin** as shown below. Use a small flatbladed screwdriver to open the spring terminals.
3. Connect the shield of the power cable to the ground spring terminal available next to **-Vin** as indicated below.

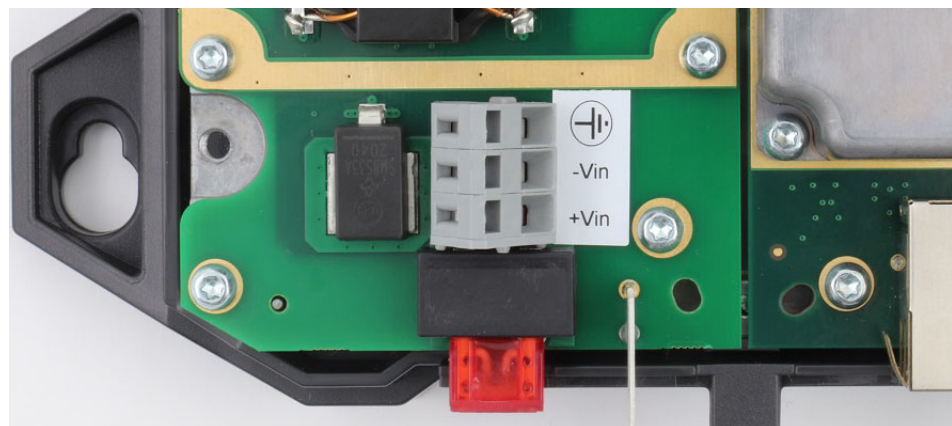

Figure 2-13: Transceiver Unit, connect power cables

4. Put the cover back on and tighten the four Torx screws to torque 0.7 Nm.
5. Use cable ties to attach the power cable to the small cable support bracket at the cable entrance.

## 2.4.5 LAN connectors

Connect one of the LAN connectors on the Transceiver Unit to one of the interface LAN ports in the left side of the Control Unit.

**Note** | The Ethernet cable between Transceiver Unit and Control Unit must be no longer than **50 m**.

**Connector type:** RJ-45 female, shielded.

**Connection cable:** Shielded Ethernet cable, e.g. Cat. 6. Max 50 m.

**Pin assignment:**

Pin number	Pin function	Wire color
1	Tx+	white/orange
2	Tx-	orange
3	Rx+	white/green
4	Not connected	blue
5	Not connected	white/blue
6	Rx-	green
7	Not connected	white/brown
8	Not connected	brown

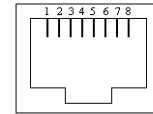

Table 2-9: Pin allocation, LAN connectors on Transceiver Unit

## 2.4.6 DSC ANT connector for DSC antenna

Use the connector marked **DSC ANT** on the rear panel to connect the DSC antenna to the radio with a 50 Ohm coaxial cable with low loss, e.g. RG214. Install a TNC connector at the cable end.

Place the antenna as high and clear of obstructions as possible. Make sure that the horizontal distance to metal parts is minimum 1.5 m (5 ft.).

**Connector type:** TNC

For more information about DSC antenna installation see *VHF and DSC antenna installation* on page 2-21.

## 2.4.7 ANT connector for VHF antenna

Use the connector marked **ANT** to connect the VHF antenna to the radio with a 50 Ohm coaxial cable with low loss, e.g. RG214. Install a TNC connector at the cable end.

Place the antenna as high and clear of obstructions as possible. Make sure that the horizontal distance to metal parts is minimum 1.5 m (5 ft.).

**Connector type:** TNC connector.

For more information about VHF antenna installation see *VHF and DSC antenna installation* on page 2-21.

## 2.5 VHF and DSC antenna installation

The SAILOR 7222 VHF DSC must be installed with one antenna for VHF RX/TX communication and one antenna for DSC communication. You can install all commonly available 50 Ohm antennas covering the appropriate frequency range and providing a VSWR less than 1.5 over this range.

For further details on equipment and antenna installation, see IMO COMSAR/Circ. 32, GUIDELINES FOR THE HARMONIZATION OF GMDSS REQUIREMENTS FOR RADIO INSTALLATIONS ON BOARD SOLAS SHIPS.

### 2.5.1 Cable requirements

Connect the antennas using a low loss type 50 Ohm coaxial cable, e.g. good quality RG214 or better. It is recommended to use a double-screened type cable (like e.g. RG214) with a maximum insertion loss of 3dB across the antenna cable installation.

The maximum antenna cable length in the installation depends on the quality of the cable, i.e. the specified attenuation (dB/m) of the cable of choice at the high end of the VHF frequency band. As a rule of thumb the cable length using e.g. RG214 coaxial cable should not exceed 25 m.

### 2.5.2 VHF RX/TX antenna

In installations with two or more VHF radios it is important to ensure the optimum performance of these by carefully selecting the antenna positions for both radios. It is recommended to maximize the RF attenuation between the VHF RX/TX antennas in the installation. You can ensure this by not having the RX/TX antennas positioned at the same horizontal level, i.e. the RX/TX antennas for each radio must be installed at shifted elevations as shown in the following drawing.

If sufficient vertical distance between two or more such antennas cannot be achieved, the horizontal distance between them is increasingly important for optimum performance. If there is hardly any vertical separation ensure that there is a minimum of 5 m horizontal distance between any RX/TX antennas in the installation.

To minimize any increase in VSWR of the VHF RX/TX antenna, install the antenna at a vertical distance of at least 2 m to any other mast, pole or other RF antennas. Keep VHF antennas as far away as possible from antenna main beam of any radar and satellite equipment.

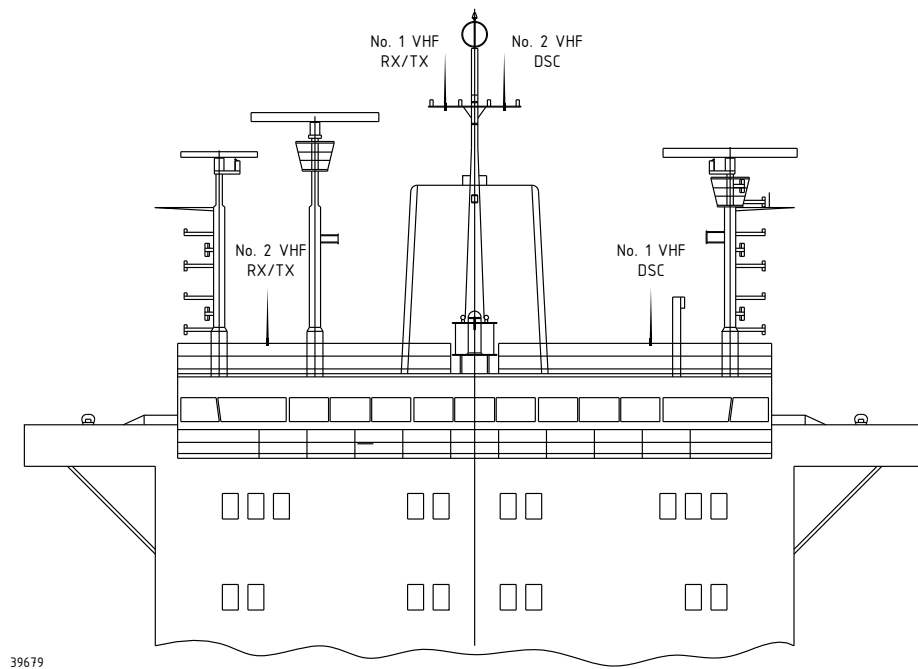

Figure 2-14: Antenna positioning 1/2

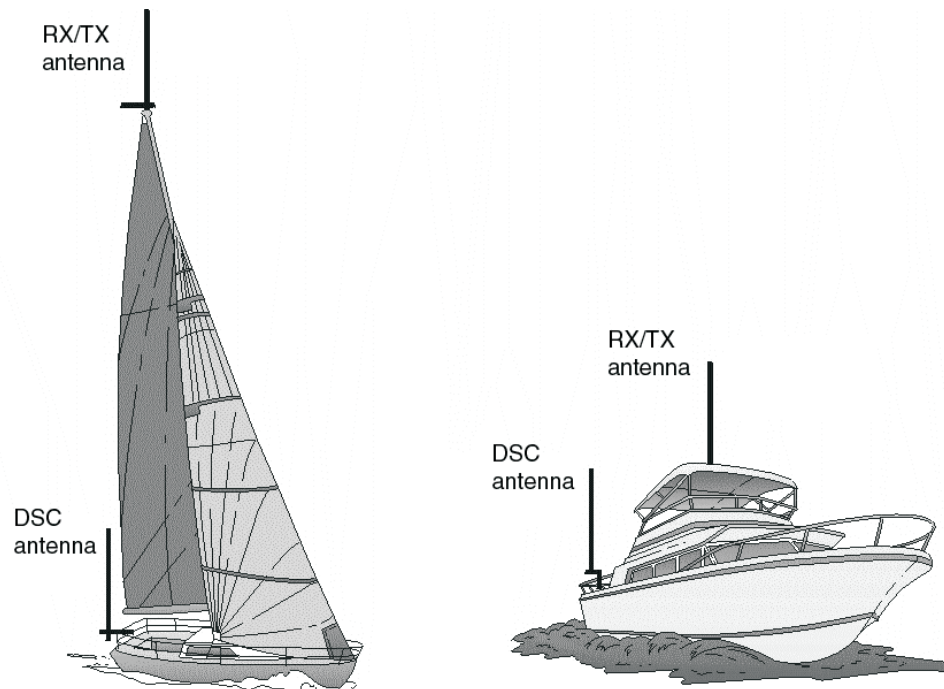

Figure 2-15: Antenna positioning, 2/2

### 2.5.3 DSC antenna

The positioning of the DSC antennas is less critical in terms of the imposed VSWR and due to the nature of the DSC signaling. Please note that the DSC receiver of a VHF radio is likely to be temporarily blocked in reception due to high signal blocking, if the DSC antenna is installed close to a transmitting RX/TX antenna at the same horizontal level.

## 2.6 Wiring of connection boxes

For part numbers of connection boxes and other accessories, see *Accessories available* on page 1-3.

### 2.6.1 Connection box SAILOR 6207

The **SAILOR 6207 Connection Box** is used to connect GNSS (NMEA), GNSS/AIS DSC modem and further SAILOR 6201 Handsets. For wiring and cabling details see *System configuration examples* on page C-1 and *How to install LAN* on page C-14.

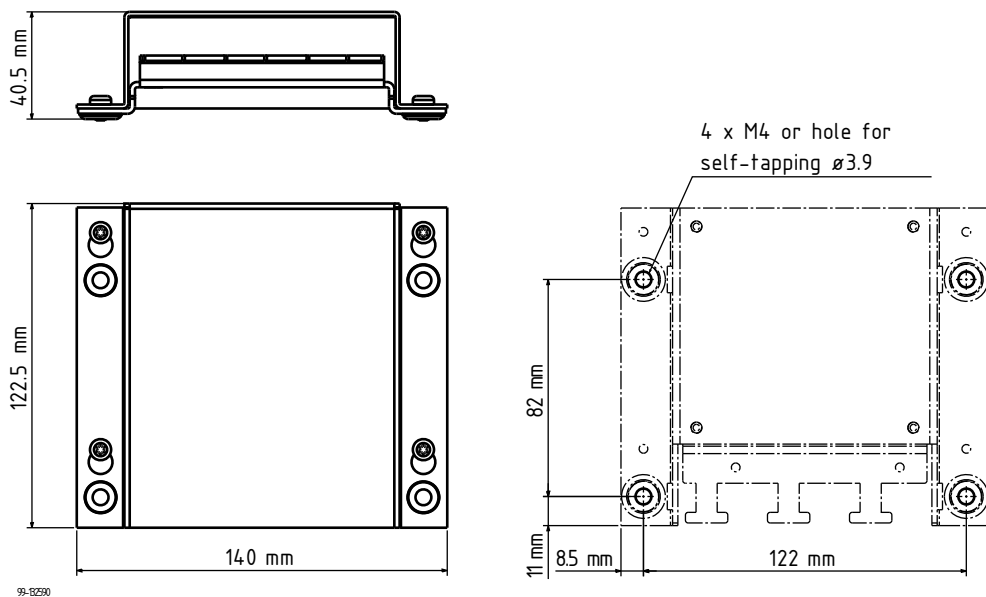

Figure 2-16: SAILOR 6207 Connection Box for parallel handsets, mounting

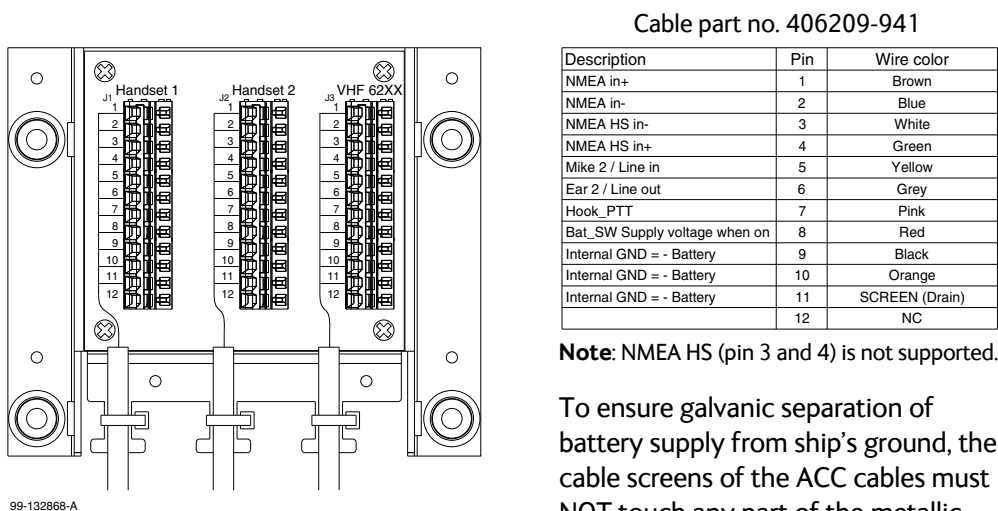

Figure 2-17: SAILOR 6207 Connection Box for parallel handsets, wiring

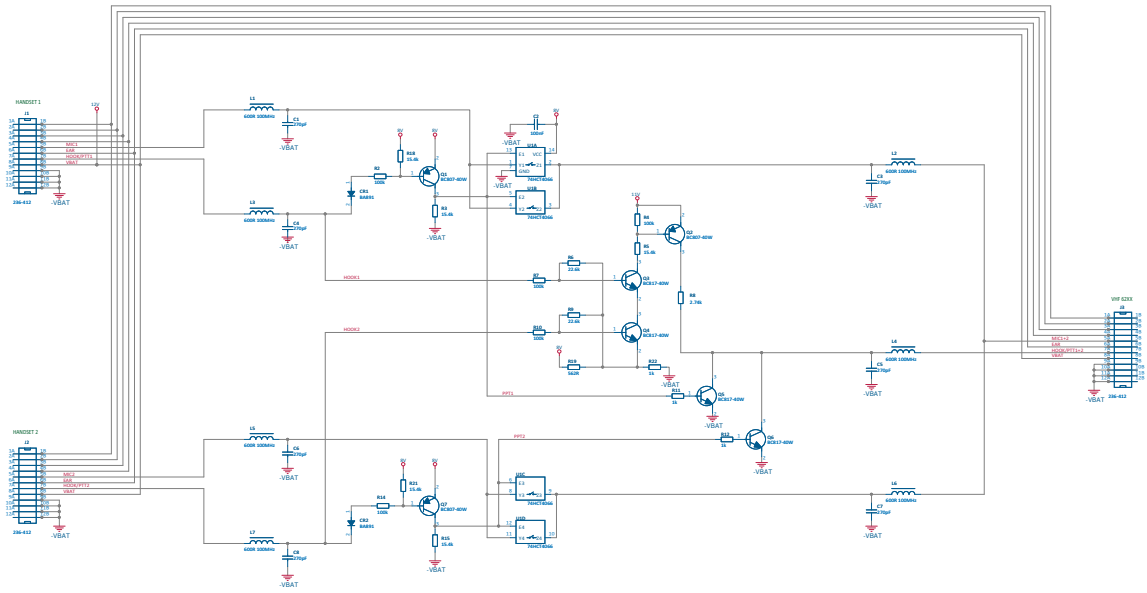

Figure 2-18: SAILOR 6207 Connection Box for parallel handsets, diagram

## 2.6.2 Connection box SAILOR 6208

The **SAILOR 6208 Connection Box** is used to connect SAILOR 6204 Control Speaker microphones and other auxiliary equipment. For wiring and cabling details see *System configuration examples* on page C-1 and *How to install LAN* on page C-14.

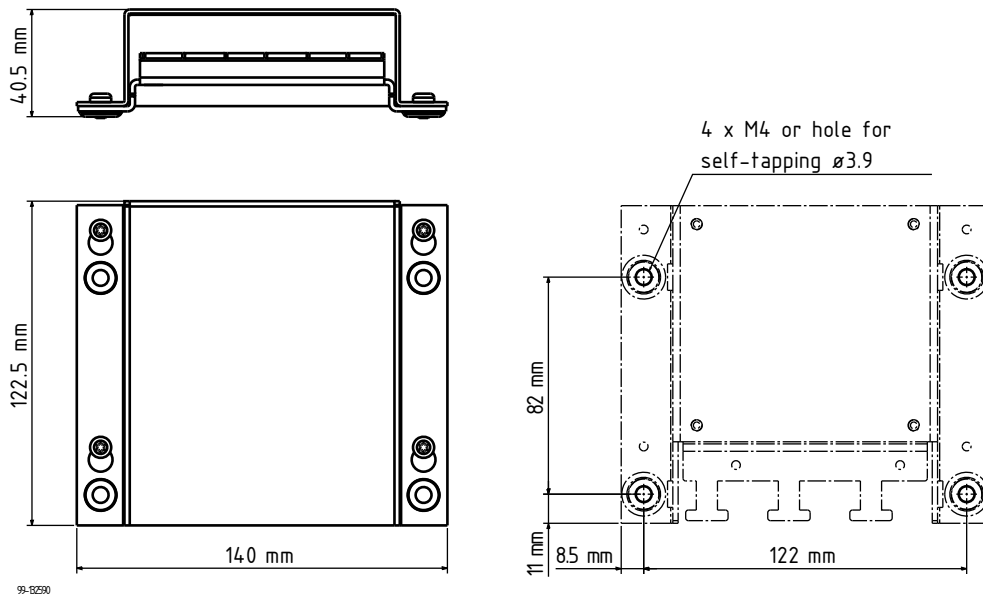

Figure 2-19: SAILOR 6208 Control Unit Connection Box, mounting

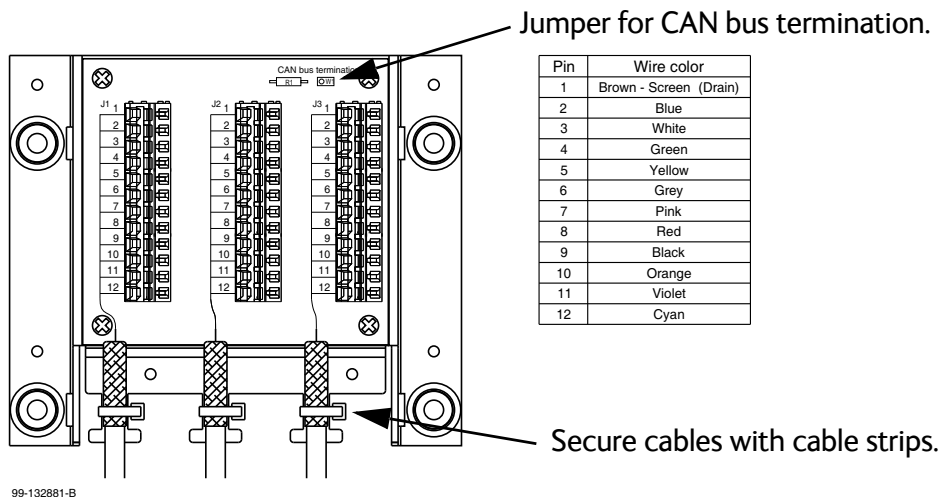

Figure 2-20: SAILOR 6208 Control Unit Connection Box for parallel handsets, wiring  
 Terminate the last SAILOR 6208 on the CAN bus (furthest away from the transceiver).

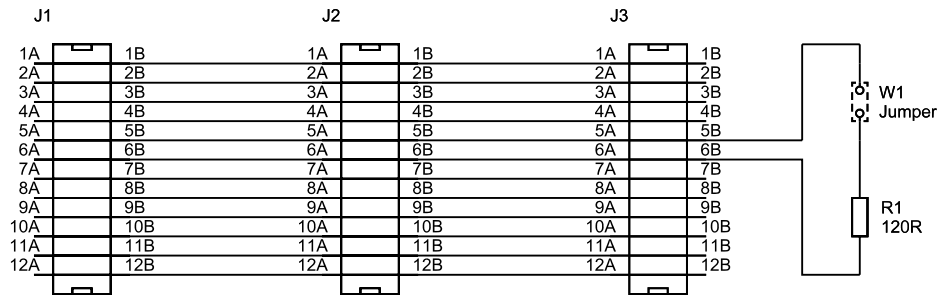

Figure 2-21: SAILOR 6208 Control Unit Connection Box, diagram



### 2.6.3 Connection box SAILOR 6209

The **SAILOR 6209 Connection Box** is used to connect to a Bridge Alert Management system (BAM;).

For wiring and cabling details see *System configuration examples* on page C-1.

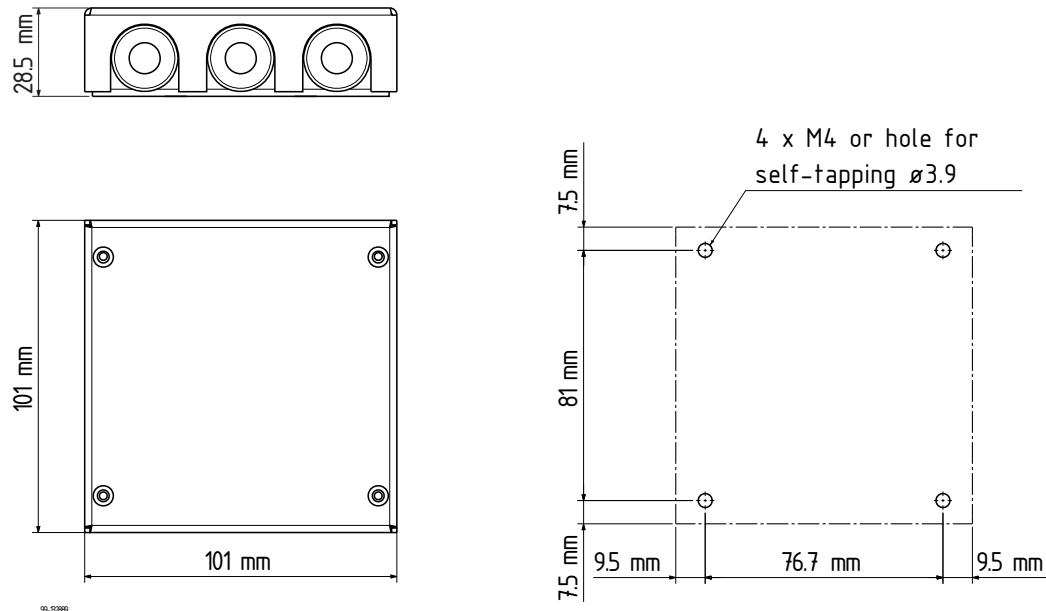
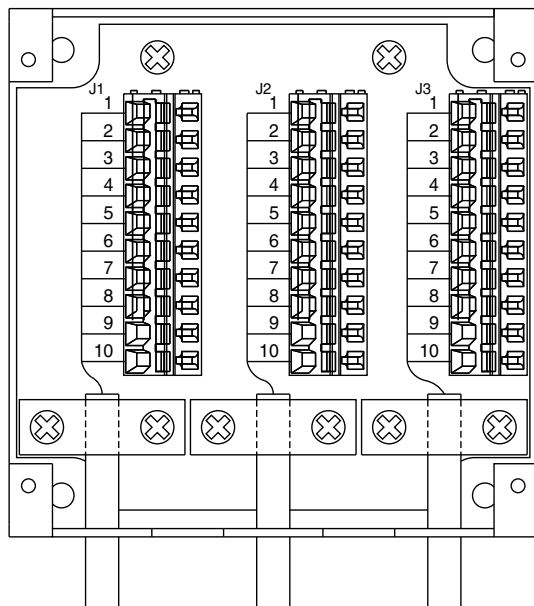

Figure 2-22: SAILOR 6209 Accessory Connection Box, mounting



Pin	Wire color
1	Brown
2	Blue
3	White
4	Green
5	Yellow
6	Grey
7	Pink
8	Red
9	Black
10	Orange - SCREEN (Drain)

99-132893-A

Figure 2-23: SAILOR 6209 Accessory Connection Box, wiring

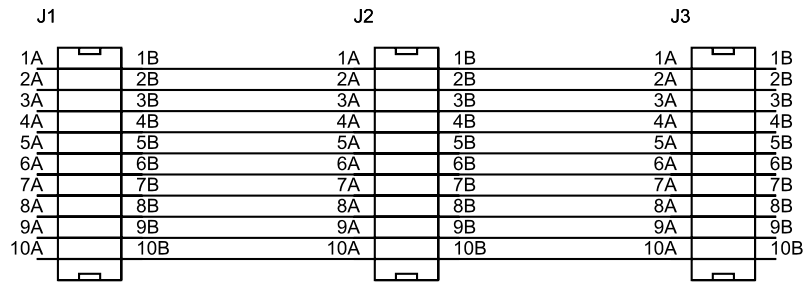

Figure 2-24: SAILOR 6209 Accessory Connection Box, diagram

## 2.7 Connect the Control Unit to the Transceiver Unit

Connect the two units as follows:

1. Connect one of the LAN connectors on the Transceiver Unit to one of the interconnection LAN ports in the left side of the Control Unit as described in *LAN connectors* on page 2-20.

### 2.7.1 Pair the Control Unit and the Transceiver Unit

1. In the Control Unit display, tap **SETTINGS > SYSTEM**.
2. Select **PAIRING**.
3. When the Transceiver Unit is found, tap the **PAIR** button.
4. The two units should now be connected.

## First-time power up

### 3.1 General use and navigation

The tasks needed to be performed during installation are described below. See the SAILOR 7222 VHF DSC User manual for instructions how to operate and set up the VHF radio.

#### 3.1.1 Power on and volume in handset and speaker

The Control Unit has a dual-function on/off knob for power on/off and volume control.

- To power on the VHF radio press the on/off knob.
- To power off the VHF radio, press and hold the on/off knob and follow the instructions in the display.
- To adjust the speaker volume, turn the volume knob (clockwise = louder, counter clockwise = softer, until muted). When muted,  is shown in the display.
- To adjust the volume of the handset earpiece see the *SAILOR 7222 VHF DSC User manual*.



#### 3.1.2 Working channel

To select a working channel use the channel selector knob or enter the channel number using on-screen the keypad.



## 3.2 Entering the MMSI number

When the VHF radio is powered on for the first time, you must enter the vessel's MMSI number. Hereafter the MMSI number is briefly displayed after power up. The MMSI is a unique, 9-digit identifier assigned to your ship.

### Important

The MMSI number must be programmed into the VHF radio to use any DSC functionality. The radio will prompt for the MMSI number at each power-up until the MMSI has been entered. An error message is displayed when trying to initiate any DSC function. However, you can use the radio in normal VHF mode.



**CAUTION!** Without a programmed MMSI number the Distress button will not work!

### 3.2.1 Entering the MMSI number

When being prompted after power up enter the MMSI number as described below:

1. In the popup, tap (TBD) to enter the **SETTINGS > DSC** menu.
2. Tap **MMSI**.
3. When prompted, enter the password.
4. Enter the 9 digits for the MMSI one by one using the on-screen keypad.
5. If you need to delete the previous digit tap the key .

### Important

The MMSI number must be programmed into the VHF radio to use any DSC functionality. The radio will prompt for the MMSI number at each power-up until the MMSI has been entered. You can use the radio in normal VHF mode.



**WARNING!** Without a programmed MMSI number the Distress button will not work!

Once programmed, the MMSI number is displayed in the DSC window directly after start-up. The DSC functionality is operational at any time.

The message **NO DSC (NO MMSI)** is shown in the DSC window if the MMSI is not programmed.

### 3.2.2 Changing the MMSI number

If you need to change the MMSI number of the SAILOR 7222 VHF DSC you need a password. do as follows:

1. From the **SETTINGS** menu, select **DSC** and then **MMSI**.
2. When prompted, enter the password.
3. Enter the 9 digits for the MMSI one by one using the on-screen keypad.
4. If you need to delete the previous digit tap the key .

## 3.3 Forced low power AUX input control

When the AUX Lo Power Forced control input is activated, the radio is forced into low power control.

For details on the AUX connector, see *AUX connector* on page 2-12.

### 3.3.1 TX inhibit

When the low power auxiliary input (above) is activated, the VHF radio is automatically Tx inhibited, i.e. it is not able to send but only receive.

## Configuration

In this chapter you find information on how to configure your SAILOR 7222 VHF DSC system.

This chapter has the following sections:

- *Administrator access*
- *SETTINGS*
  - *RADIO*
  - *CONTROLLER*
  - *CHANNELS*
  - *DSC*
  - *POWER SUPPLY*
  - *NMEA*
  - *NETWORK*
  - *SYSTEM*
  - *REMOTE CONTROL*
  - *ABOUT*

### 4.1 Administrator access

#### 4.1.1 Password-protected settings

A number of settings are password-protected and can only be accessed with an administrator password. Password-protected settings are marked with this symbol  in the menu tree and in the user interface.

**You find the password on the type label on the back of the SAILOR 7224 Control Unit.**

When you try to access one of the password-protected settings, you are prompted for the password. After you have entered the password, all settings are available for 10 minutes or until restart. After that you will have to enter the password again to access password-protected settings.

## 4.2 SETTINGS

The following settings pages are described in this section of the manual:

- *RADIO*
- *CONTROLLER*
- *CHANNELS*
- *DSC*
- *POWER SUPPLY*
- *NMEA*
- *NETWORK*
- *SYSTEM*
- *REMOTE CONTROL*
- *ABOUT*

### 4.2.1 Accessing a settings page

To change a setting in one of the **SETTINGS** pages, do as follows

1. Tap **SETTINGS**. If it is not in the display, tap  and then **SETTINGS**
2. Tap the settings page you want to edit.

**Note**

Settings requiring a password are marked with a lock icon . You can see these settings without a password, but you cannot edit them.

3. Tap  to go one step back, or  to return to normal radio operation.

## 4.2.2 The SETTINGS menu tree

Below is the SETTINGS menu tree. Password-protected settings are marked with 

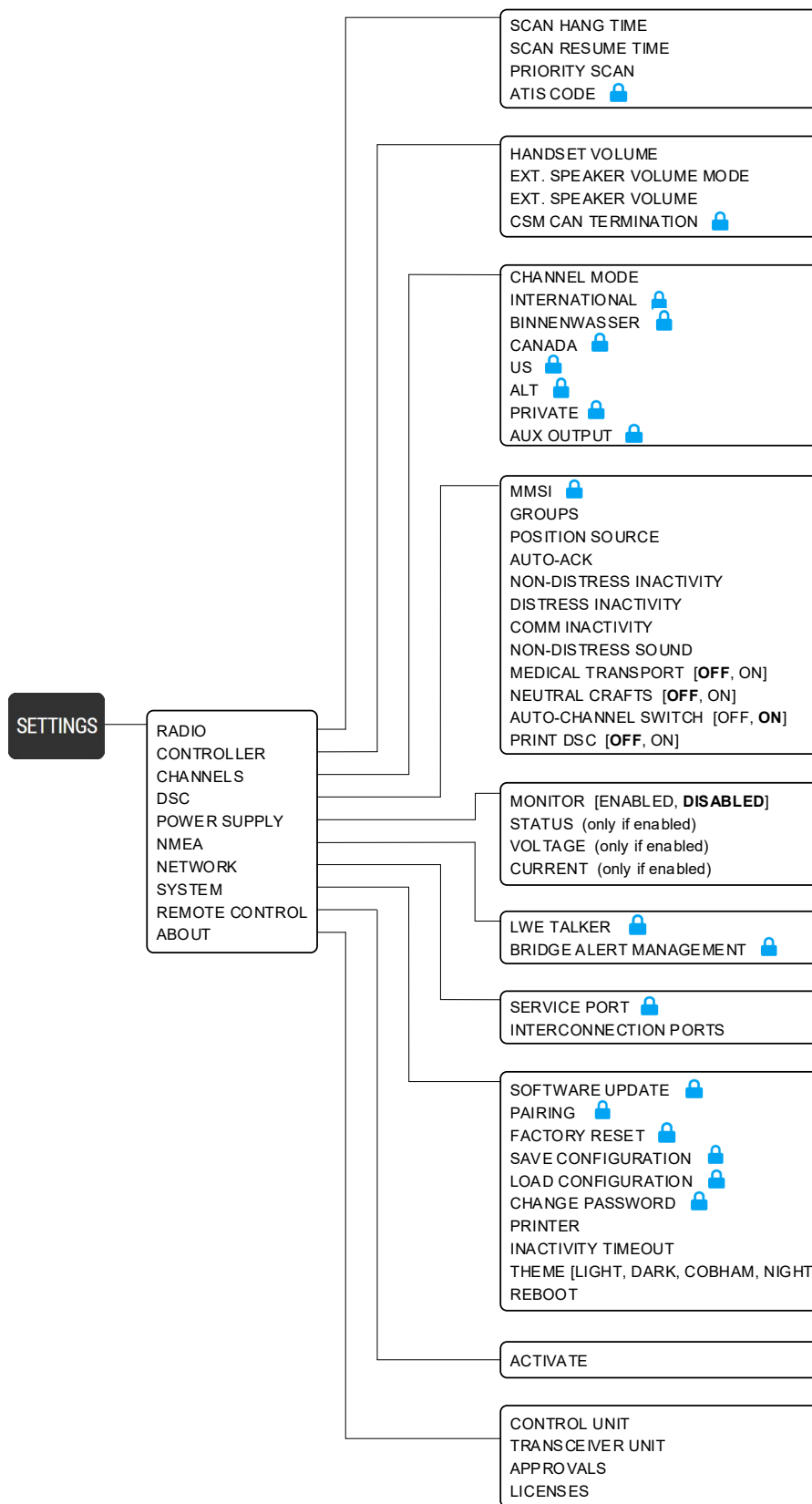

Figure 4-1: SETTINGS menu tree



### 4.2.3 RADIO

The RADIO menu holds the settings for the radio functions in the VHF radio.

Parameter	Description
<b>SCAN HANG TIME</b>	<p>Scan hang time, in seconds on an active receiving working channel. The time is measured from the signal is detected. The radio remains on the channel for the set time interval, if a signal was detected.</p> <p><b>OFF:</b> Resumes scanning when signal disappears (default)  <b>4, 6, 8, 10:</b> Hang time in seconds.</p>
<b>SCAN RESUME TIME</b>	<p>Scan resume time, in seconds. When the programmed time of inactivity has elapsed, and when watch/scan has been aborted using a push on PTT, or after power-up, scan or watch is resumed.</p> <p><b>OFF:</b> Automatic resume is deactivated (default)  <b>3, 6, 10, 15, 20, 25, 30:</b> Resume time in seconds.</p>
<b>PRIORITY SCAN</b>	<p><b>ON:</b> All channels tagged for scanning are scanned while monitoring channel 16 (default).  <b>OFF:</b> Only the channels tagged for scanning are scanned in sequence, not channel 16, unless it is tagged for scanning.</p>
<b>ATIS CODE</b> 	<p>10 digit numerical (Default: not set, password protected if set).</p> <p>The ATIS code is used for identification to marine coast and inland stations and its use is mandatory in a number of European inland waterways. The ATIS number is issued by the relevant authority.</p> <p>For ships coming from states which are not member of the Regional Arrangement, the ATIS-Code is based on the MMSI with a 9 as the first digit.<sup>a</sup></p>

Table 4-1: SETTINGS > RADIO menu

a. The Committee RAINWAT in its 12. Meeting (October 2008) decided to change the building rules of the ATIS code for vessels coming from a country outside the RAINWAT arrangement.

## 4.2.4 CONTROLLER

Each of the controlling devices connected and powered has its own setting. The available settings may vary from controllers applied.



Parameter	Description
<b>HANDSET VOLUME</b>	Adjust earpiece volume for handset 1: ON, can be adjusted from OFF to 100, in steps of 5.
<b>EXT. SPEAKER VOLUME MODE</b>	<b>FIXED:</b> Fixed level is set for external speaker <b>RELATIVE:</b> Relative level following volume adjustment of the internal speaker.
<b>EXT. SPEAKER VOLUME</b>	External speaker fixed volume: <b>OFF</b> , 5 to 100 in steps of 5.
<b>CSM CAN TERMINATION</b> 	Termination of the CAN interface in the VHF radio: <b>ON</b> or <b>OFF</b> .

Table 4-2: SETTINGS > CONTROLLER menu

## 4.2.5 CHANNELS

Use the CHANNELS menu to configure the channel settings for the VHF radio.

Parameter	Description
<b>CHANNEL MODE</b>	Select CHANNEL MODE to select the channel table for the primary channel. Channel tables available: <b>INT</b> , <b>BI</b> , <b>US</b> , <b>CA</b> , <b>ALT</b> . Below CHANNEL MODE all the channel tables are listed.
<b>CALL CHANNEL</b>	The call channel for the selected channel table is displayed and can be changed at the top of each channel table. Select the channel you want to use as a programmed call channel. This channel is used as one channel in triple watch and when you tap and hold the <b>16/C</b> button.
<b>INT. CHANNELS</b> <b>BI. CHANNELS</b> <b>US. CHANNELS</b> <b>CA. CHANNELS</b> 	You can view and change the settings for each channel (change is password protected). Tap a channel to access the properties for the channel. See the table on the next page for accessible properties for each channel table. Tap  to return to <b>CHANNELS</b> .

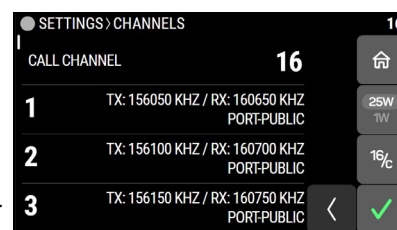

Table 4-3: SETTINGS > CHANNELS menu



Parameter	Description
<b>ALT. CHANNELS</b> 	As described above, plus add or delete channels.
<b>PRIVATE CHANNELS</b> 	As described above, plus add or delete channels.
<b>AUX OUTPUT</b>	<p>Configuration of the AUX port:</p> <p>MODE: <b>OFF</b> (default), SQUELCH OPEN, ON CHANNEL.</p> <p>CHANNEL: Shows selected channel for AUX.</p> <p>If <b>SQUELCH OPEN</b> is selected, the AUX port is activated when the squelch opens on the selected channel. If <b>ON CHANNEL</b> is selected, the port is activated when the radio is on the selected AUX channel.</p> <p><b>Example:</b> If you select MODE = SQUELCH OPEN, and you have selected AUX in channel 12, the AUX output (pin 5 in AUX connector) will be activated (go low) when squelch is opened on channel 12. For pinout for AUX connector, see <i>AUX connector</i> on page 2-12.</p>

Table 4-3: SETTINGS > CHANNELS menu (Continued)

### Editable properties for the channels in each channel table

The table below shows the properties that may be edited for each channel, depending on which channel table the channel belongs to.

Property	INT	BI	CA	US	ALT	Private
<b>DESIGNATOR</b>					x	x
<b>NAME</b>	x	x	x	x	x	x
<b>25 W ALLOWED</b>	x		x	x	x	x
<b>TX BLOCK</b>	x	x	x	x	x	x
<b>ATIS</b>	x	x	x	x	x	x
<b>AUX</b>	x	x	x	x	x	x
<b>PROPOSE FOR DSC</b>	x	x	x	x	x	x
<b>RX FREQUENCY</b>					x	x
<b>TX FREQUENCY</b>					x	x
<b>AVAILABILITY</b>						x
<b>ADD or DELETE channel</b>					x	x

Table 4-4: SETTINGS > CHANNELS, channel properties

Table 4-5 on page 4-7 explains each of the channel properties.

Explanation of the channel properties:

Setting	Explanation
<b>DESIGNATOR</b>	The channel number (note: Private channels are prefixed with <b>P</b> ).
<b>NAME</b>	The name of the channel.
<b>25 W ALLOWED</b>	Allow this channel to transmit with high power (25 W).
<b>TX BLOCK</b>	Block transmitting on this channel.
<b>ATIS</b>	Transmit the ATIS code (entered in the RADIO menu) at the end of every voice transmission on this channel.
<b>AUX</b>	Select AUX on this channel to use the channel to activate the AUX OC output e.g. on Squelch Open or On Channel as configured in the AUX OUTPUT setting in the CHANNELS menu. Note: Only one single channel can be used for AUX.
<b>PROPOSE FOR DSC</b>	Propose using this channel for DSC calls. Only channels with this tag can be selected for DSC sub-communication.
<b>RX FREQUENCY</b>	The receiving frequency (only on ALT and Private channels)
<b>TX FREQUENCY</b>	The transmitting frequency (only on ALT and Private channels).
<b>AVAILABILITY</b>	Only in Private channel table: Select whether or not the channel should be available in the other channel tables.
<b>ADD or DELETE channel</b>	Only possible for ALT or Private channel table: You can add or delete channels in the channel table.

Table 4-5: Explanation of channel properties

## 4.2.6 DSC

The DSC menu holds the settings used for DSC communication.

Parameter	Description
<b>MMSI</b> 	The MMSI of the radio. 9 digit numerical (Default: Not set, password protected if set). See <i>Entering the MMSI number</i> for a step-by-step description.
<b>GROUPS</b>	Shows DSC groups. You can add, edit and delete groups here. Each entry in a group consists of MMSI, name and “listen to group”.
<b>POSITION</b>	<ul style="list-style-type: none"> <li>• SOURCE: <b>GNSS</b> (default) or <b>MANUAL</b>.</li> <li>• GNSS INPUT PORT:                             <ul style="list-style-type: none"> <li>• <b>AUTOMATIC</b>: Automatically select position source with the best quality. In <b>Automatic</b> mode the position device transmitting sentences with the best quality indicator will be used as position source.</li> <li>• <b>NMEA</b>: NMEA 1 position input.</li> <li>• <b>NMEA HS</b>: NMEA 2 position input.</li> <li>• <b>LWE1</b>: Specific LWE position input (see LWE Talkers below).</li> <li>• <b>LWE2</b>: Specific LWE position input (see LWE Talkers below).</li> <li>• <b>LWE3</b>: Specific LWE position input (see LWE Talkers below).</li> <li>• <b>INM-C</b>: SAILOR Inmarsat C position input.</li> </ul> </li> <li>• CURRENT AUTOMATIC GNSS INPUT (if GNSS INPUT PORT is <b>AUTOMATIC</b>): NMEA, NMEA HS, LWE1, LWE2, LWE3 or INM-C (read only).</li> <li>• CURRENT POSITION (editable if source is <b>MANUAL</b>):                             <ul style="list-style-type: none"> <li>• LATITUDE.</li> <li>• LONGITUDE.</li> <li>• UTC TIME.</li> </ul> </li> <li>• LWE1: AUTO or specific Talker ID.</li> <li>• LWE2: AUTO or specific Talker ID.</li> <li>• LWE3: AUTO or specific Talker ID.</li> </ul>

Table 4-6: SETTINGS > DSC menu

Parameter	Description
<b>AUTO-ACK</b>	<p>Auto-acknowledgment:</p> <ul style="list-style-type: none"> <li>• <b>Test:</b> Auto-acknowledgment of test DSC messages. Disabled or <b>Enabled</b> (default).</li> <li>• <b>Poll:</b> Auto-acknowledgment of polling DSC messages. Disabled or <b>Enabled</b> (default).</li> <li>• <b>Position:</b> Auto-acknowledgment of position DSC messages. <b>Disabled</b> (default) or Enabled.</li> <li>• <b>Individual:</b> Auto acknowledgment of individually addressed, non distress DSC messages with channel unavailable for communication. Disabled or <b>Enabled</b> (default).</li> </ul>
<b>NON-DISTRESS INACTIVITY</b>	<p>Inactivity time-out to exit non-distress functions (e.g. in setup) without automatic time-out: Range: OFF, 1 to 30 minutes, in 1 min. steps Default: <b>15min.</b></p>
<b>DISTRESS INACTIVITY</b>	<p>Inactivity time-out for received distress DSC automated procedures without automatic time-out: Range: OFF, 1 to 30 minutes, in 1 min. steps. Default: <b>OFF.</b></p>
<b>COMM INACTIVITY</b>	<p>Inactivity time-out of non DSC communication (VHF). Range: 10 to 600 seconds, in 10 s steps. Default: <b>30sec.</b></p>
<b>NON-DISTRESS SOUND</b>	<p>Sound at non-distress DSC alarms:</p> <ul style="list-style-type: none"> <li>• <b>OFF:</b> Sound disabled.</li> <li>• <b>Single ring:</b> Sound only once (default).</li> <li>• <b>Repeated ring:</b> Repeat sound cyclic.</li> </ul>
<b>MEDICAL TRANSPORT</b>	<ul style="list-style-type: none"> <li>• <b>ON:</b> This option is available in DSC calls of the type Urgency.</li> <li>• <b>OFF</b> (default).</li> </ul>
<b>NEUTRAL CRAFTS</b>	<ul style="list-style-type: none"> <li>• <b>ON:</b> This option is available in DSC calls of the type Urgency.</li> <li>• <b>OFF</b> (default).</li> </ul>
<b>AUTO CHANNEL SWITCH</b>	<ul style="list-style-type: none"> <li>• <b>OFF:</b> Automatic channel switching is disabled, icon LCK will be visible in stand-by mode.</li> <li>• <b>ON:</b> Automatic channel switching is enabled (default).</li> </ul>
<b>PRINT DSC</b>	<p>For printing of DSC messages on a printer connected to the system.</p> <ul style="list-style-type: none"> <li>• <b>ON.</b></li> <li>• <b>OFF</b> (default).</li> </ul>

Table 4-6: SETTINGS > DSC menu (Continued)

## 4.2.7 POWER SUPPLY

If you are using a SAILOR 6081A Power Supply and Charger with your VHF radio, you can set up the VHF radio to monitor the power supply.

Parameter	Description
<b>MONITOR</b>	Set this to <b>ENABLED</b> if the radio is connected to a TT-6081A Power Supply and Charger. Set this to <b>DISABLED</b> (default) for any other power supply.
<b>STATUS</b>	If MONITOR enabled: Current status of the connected power supply.
<b>VOLTAGE</b>	If MONITOR enabled: Current voltage.
<b>CURRENT</b>	If MONITOR enabled: Current current.

Table 4-7: SETTINGS > POWER SUPPLY menu

## 4.2.8 NMEA

In the NMEA menu you can type in the LWE talker ID and set up the interfaces used for Bridge Alert Management (BAM).



Parameter	Description
<b>LWE TALKER</b> 	CVnnnn, default: Random generated ID. Use the on-screen keypad to type in the correct ID (typically done during installation).
<b>BRIDGE ALERT MANAGEMENT (BAM)</b> 	<ul style="list-style-type: none"> <li>LWE: <b>ON</b> (default) or OFF.</li> <li>MULTICAST GROUP (if LWE=ON): <b>BAM1</b> (default), BAM2, RCOM or USR1-8.</li> <li>CLUSTER: The LWE cluster used. NAV or <b>COM</b> (default).</li> <li>OPT: ON or <b>OFF</b> (default).</li> </ul>

Table 4-8: SETTINGS > NMEA menu

## 4.2.9 NETWORK

There are 3 LAN connectors on the Control Unit. The LAN connector next to the USB connector is the Service port, e.g. used for accessing the settings of the Control Unit, the two leftmost LAN connectors are for connecting to the Transceiver Unit and to other units in the system in a local network.

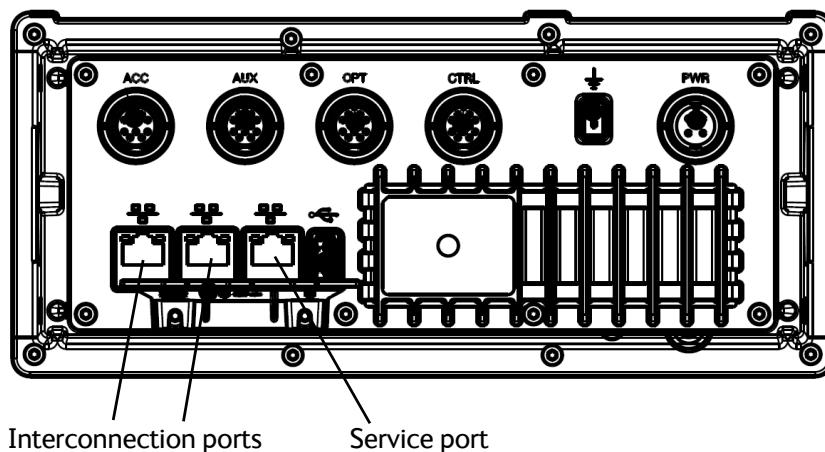

Parameter	Description
<b>SERVICE PORT</b> 	Configuration of the Service port (LAN connector). <ul style="list-style-type: none"> <li>IP Mode: <b>DHCP Client</b> (default) or Static.</li> <li>IP address (only editable if Static is selected).</li> <li>Netmask (only editable if Static is selected).</li> <li>Gateway (only editable if Static is selected).</li> </ul>
<b>INTER-CONNECTION PORTS</b>	<ul style="list-style-type: none"> <li>IP address (Read only).</li> <li>Netmask (Read only).</li> <li>Gateway (Read only).</li> </ul> If a DHCP server is not available, the interconnection ports automatically use zeroconf to obtain an IP address.

Table 4-9: SETTINGS > NETWORK menu



## 4.2.10 SYSTEM







Parameter	Description
<b>SOFTWARE UPDATE</b> 	<ul style="list-style-type: none"> <li>• USB Mass Storage: Select a tiif file from a connected USB device.</li> <li>• Upload: Select a tiif file from a connected PC.</li> </ul>
<b>PAIRING</b> 	<p><b>If not paired:</b></p> <p>Opens a list of all nearby Transceiver Units (TU) with</p> <ul style="list-style-type: none"> <li>• Serial number.</li> <li>• pairing status (paired to another Control Unit (CU) or not).</li> <li>• SW version.</li> <li>• Pairing button for pairing the CU to the TU.</li> </ul> <p><b>If paired:</b></p> <p>Shows information on the TU that the CU is paired to:</p> <ul style="list-style-type: none"> <li>• Serial number.</li> <li>• SW version and SW version compatibility.</li> <li>• Unpair button for unpairing the TU from the CU.</li> </ul>
<b>FACTORY RESET</b> 	<p>Resets the radio to factory defaults.</p> <p>Tap <b>OK</b> to confirm.</p>
<b>SAVE CONFIGURATION</b> 	<ul style="list-style-type: none"> <li>• USB Mass Storage: Save the configuration to a connected USB device.</li> <li>• Download: Save the configuration to a connected PC.</li> </ul>
<b>LOAD CONFIGURATION</b> 	<ul style="list-style-type: none"> <li>• USB Mass Storage: Select a configuration file from a connected USB device.</li> <li>• Upload: Select a configuration file from a connected PC.</li> </ul>
<b>CHANGE PASSWORD</b> 	<p>Change the password for accessing password-protected parts of the user interface.</p>
<b>PRINTER</b>	<p>Select a printer (if one or several printers are part of the system). Note whether there is immediate print upon DSC activity, You must set <b>Print DSC</b> to <b>ON</b> see <i>DSC</i> on page 4-8.</p> <p>Recommended commercially available printer-servers: SAILOR 6004 Control Panel.</p>
<b>INACTIVITY TIMEOUT</b>	<p>Inactivity time-out to exit functions (e.g. in Settings) and return to the application.</p> <p>Range: 1 to 30 minutes, in 1 minute steps.</p> <p>Default: <b>10 min.</b></p>

Table 4-10: SETTINGS &gt; SYSTEM menu

Parameter	Description
<b>THEME</b>	Changes the display color: <ul style="list-style-type: none"> <li>• <b>LIGHT</b> (default).</li> <li>• <b>DARK</b>.</li> <li>• <b>COBHAM</b>.</li> <li>• <b>NIGHT</b>.</li> </ul>
<b>REBOOT</b>	Reboots the VHF radio.

Table 4-10: SETTINGS > SYSTEM menu (Continued)

### 4.2.11 REMOTE CONTROL

When you activate Remote control, you can access the graphical user interface from any unit with a browser installed.

**Note** If you access any of the controls on the physical Control Unit while remote control is used, the remote control is deactivated and you have to activate it again to be able to use it.

Parameter	Description
<b>ACTIVATE</b>	Opens the API and GUI for access through external LAN ports. A popup shows connection status and a button for deactivating.

Table 4-11: SETTINGS > REMOTE CONTROL

To connect to the Control Unit after activating, do as follows:

1. Connect your device to one of the LAN connectors on the SAILOR 7224 Control Unit
2. Open your browser and type `http://<CU IP>`, where <CU IP> is the IP address of the Control Unit.  
You find the IP address of the Control Unit in the **NETWORK** menu in the Control Unit or in the **TMA (Thrane Management System)**, if you have a PC with TMA connected.

The web interface now opens and lets you control the system from your connected device instead of on the Control Unit display.

## 4.2.12 ABOUT

The ABOUT menu holds information on the units in the system.

Parameter	Description (read only)
<b>CONTROL UNIT</b>	<ul style="list-style-type: none"><li>• Serial number.</li><li>• Hardware Tracking Number.</li><li>• Software version.</li></ul>
<b>TRANSCEIVER UNIT</b>	<ul style="list-style-type: none"><li>• Serial number.</li><li>• Hardware Tracking Number.</li><li>• Software version.</li></ul>
<b>APPROVALS</b>	Lists approvals for the SAILOR 7222 VHF DSC, e.g. FCC.
<b>LICENSES</b>	Lists licenses for the SAILOR 7222 VHF DSC, e.g. GPL.

Table 4-12: SETTINGS > ABOUT

# Service & maintenance

## 5.1 Contact for support

Contact your authorized dealer for technical service and support of the VHF radio. Before contacting your authorized dealer you can go through the troubleshooting guide to solve some of the most common operational problems.

## 5.2 Software update

### 5.2.1 Update software from a USB memory stick

To update software from a USB memory stick in the Control Unit, do as follows:

1. Download the new software<sup>1</sup> or acquire the software from Cobham SATCOM and save it to a USB memory stick.
2. Connect the USB memory stick with the new software to the USB interface on the Control Unit.
3. Tap **SETTINGS > SYSTEM** on the Control Unit display.
4. Tap **SOFTWARE UPDATE**.
5. Select **USB MASS STORAGE**.
6. Browse and select the .tiff file with the new software.
7. Follow the instructions on the screen to complete the software update.

### 5.2.2 Update software from a computer.

To update software from a connected computer, do as follows:

1. Download the new software<sup>1</sup> or acquire the software from Cobham SATCOM and save it to your computer.
2. Connect your computer to one of the LAN connectors on the Control Unit.
3. In the Control Unit display, activate remote control of the Control Unit and access the user interface from your browser as described in *REMOTE CONTROL* on page 4-13.
4. In the web interface on the computer, select **SETTINGS > SYSTEM** and then **SOFTWARE UPDATE**.
5. Select **UPLOAD**.
6. Browse and select the .tiff file with the new software.
7. Follow the instructions on the screen to complete the software update.

---

1. You can download the software from the Cobham SYNC Partner Portal at [www.cobhamsatcom.com](http://www.cobhamsatcom.com). Select Cobham SYNC Partner Portal > Downloads and locate the SAILOR 7222 VHF DSC software.

## 5.2.3 Update software using the TMA

### The ThraneLINK Management Application

The ThraneLINK Management Application (TMA) is a Windows program that provides monitoring and software update of connected Cobham SATCOM devices with ThraneLINK support. The devices must be on the same LAN.

### Install the TMA

#### PC requirements

- Standard PC with Windows 7, 8, 10, Vista or XP, and Ethernet connection.
- Make sure that you have administrator rights for the PC.

#### Installation

To install the TMA, do as follows:



1. Go to [www.cobhamsatcom.com](http://www.cobhamsatcom.com).
2. Select **Cobham SYNC Partner Portal**.
3. Select **Downloads > Product software > Maritime**.
4. Locate the **ThraneLINK Management Application** software package and download it to your PC.
5. Extract the files from the zip file.
6. Click **setup.exe** to start the installation wizard.  
On Windows Vista/7/8/10, when prompted, select **Yes** to allow the installation to make changes to the computer.
7. Follow the instructions in the wizard.

When the wizard is complete an icon appears on your PC desktop.  You can also find the TMA under Programs > Thrane > TMA.

If you have problems with your Firewall settings, please refer to the TMA quick guide, available on the **Cobham SYNC Partner Portal** under **Downloads > Manuals > Maritime**.

## Update software with the TMA

To update software in a ThraneLINK product, do as follows:

1. Connect the PC to the LAN with the ThraneLINK products for which you want to update software.
2. Click the TMA icon on the PC's desktop. The program starts and displays the ThraneLINK products found on the network.  
If a Windows Security Alert pops up click **Allow access** or **Unblock** (depending on your Windows version).
3. Insert a USB memory stick with the new software version (placed in the root) into a USB connector in the PC.<sup>1</sup>  
The TMA automatically discovers the new software version(s) and a software update icon flashes next to the unit(s) for which the software can be installed. 
4. From the main page of the TMA, select the product you want to update.
5. Select **Software update** at the bottom of the product page.   
Check that the new software version is correct.
6. Select **Update**.

The progress of the software update is shown in percent under the product icon. When installation is completed, a check mark appears instead.

**Note** | The installation is not complete until the Control Unit and the Transceiver Unit have rebooted. Check the new software version after reboot to verify that the installation is successfully completed.

**Note** | There can be two software updates: One for the Control Unit and one for the Transceiver Unit.

- 
1. If the new software is not automatically found, you can point to the location of the software. Select the tool icon in the **Software update** page, select **Search for software** and enter the location of the software. 

## 5.3 Alerts in the Bridge Alert Management system (BAM)

### Important

The word **Alert** is used in two different ways in this manual:

- In the BAM system an alert is a ship-internal message from connected equipment to the bridge.
- In DSC an alert is a signal sent over the air to other ships and/or coast stations, e.g. when you push the red Distress button.

Alerts from the Bridge Alert Management (BAM) system are shown in the display of the Control Unit and are read-only. A tap on the icon in the lower right corner displays a list of all active alerts.

The icons to signal alerts in the BAM system are shown below:



Warning: Active acknowledged alert



Caution: Alert



Warning: Active transferred alert



Warning: Active unacknowledged alert, silent



Warning: Active unacknowledged alert



Status OK, no active alerts



Warning: Inactive unacknowledged alert, rectified

For a list of possible alerts, see *List of BAM alerts* on page A-6.

## 5.4 DSC self test

To run a control routine DSC self test, do as follows:

1. From the Idle screen, tap **DSC**.
2. Tap **SELF TEST**.

The test will check the ability to encode/decode DSC signaling on RF level. The radio will automatically transmit a DSC safety test call to its own MMSI number without enabling the transmitter power amplifier. In parallel the radio decodes and compares the received call to be the same as the transmitted. The display shows the result of the test.

3. Press **OK** to acknowledge the test result and resume normal operation.

### Important

If the DSC loopback test fails, this indicates the DSC functionality does not work correctly — including the ability to send a DISTRESS message.

Contact your dealer immediately for further advice.

## 5.5 Maintenance

### 5.5.1 Preventive maintenance

Maintenance of the SAILOR 7222 VHF DSC can be reduced to a maintenance check at each visit of the service staff. Inspect the radio for mechanical damages, salt deposits, corrosion and any foreign material. Due to its robust construction and ruggedness the radio has a long lifetime. Anyway it must carefully be checked at intervals not longer than 12 months - dependent on the current working conditions.

### 5.5.2 Replacing the fuse

One fuse is installed in the Transceiver Unit. If the fuse is blown, do as follows:

1. Track down why the fuse was blown and solve the problem.
2. Take out the old fuse.
3. Insert the new fuse. The fuse rating is 10 A T.

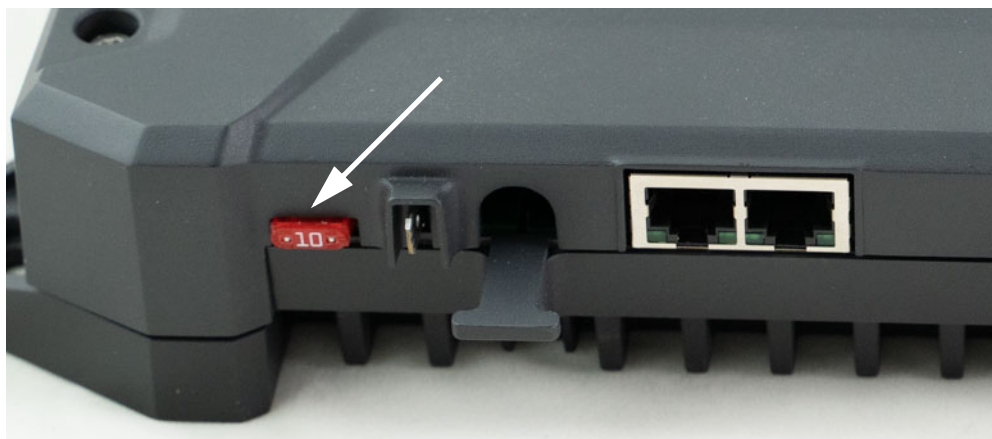

Figure 5-1: Fuse in Transceiver Unit



## 5.6 Returning units for repair

Should your Cobham SATCOM product fail, contact your dealer or installer, or the nearest Cobham SATCOM partner. You will find the partner details on [www.cobhamsatcom.com/where-to-buy](http://www.cobhamsatcom.com/where-to-buy). You can also access [www.cobhamsatcom.com](http://www.cobhamsatcom.com) and select **COBHAM SYNC PARTNER PORTAL**, which may help you solve the problem. Your dealer, installer or Cobham SATCOM partner will assist you whether the need is user training, technical support, arranging on-site repair or sending the product for repair. Your dealer, installer or Cobham SATCOM partner will also take care of any warranty issue.

### 5.6.1 Repacking for shipment

Should you need to send the product for repair, please read the below information before packing the product.

The shipping carton has been carefully designed to protect the SAILOR 7222 VHF DSC and its accessories during shipment. This carton and its associated packing material should be used when repacking for shipment. Attach a tag indicating the type of service required, return address, part number and full serial number. Mark the carton FRAGILE to ensure careful handling.

**Note** | Correct shipment is the customer's own responsibility.

If the original shipping carton is not available, the following general instructions should be used for repacking with commercially available material.

1. Wrap the defective unit in heavy paper or plastic. Attach a tag indicating the type of service required, return address, part number and full serial number.
2. Use a strong shipping container, e.g. a double walled carton.
3. Protect the front- and rear panel with cardboard and insert a layer of shock-absorbing material between all surfaces of the equipment and the sides of the container.
4. Seal the shipping container securely.
5. Mark the shipping container FRAGILE to ensure careful handling.

Failure to do so may invalidate the warranty.

# Specifications

## A.1 SAILOR 7226 VHF Transceiver Unit

Item	Specification
Weight	1.5 kg (3.3 lbs)
Dimensions	Height: Outer dimension 161 mm Width: Outer dimension 306 mm Depth: Outer dimension 51 mm
Operating temperature	-15°C to 55°C (5°F to 131°F)
Storage temperature	-25°C to 70°C (-13°F to 158°F)
Ingress Protection	IP20
Power supply	24 VDC +30%/-10%
Power consumption (typical)	Rx operative: 8 W Tx 25 W operative: 65 W Tx 1 W operative: 18 W
Heat dissipation (typical)	Rx operative: 8 W Tx 25 W operative: 40 W Tx 1 W operative: 17 W
RX/TX ant. Input/output	50 ohm @ TX voice/TX DSC & RX voice
DSC ant. Input	50 ohm @ RX DSC
LAN	2 LAN ports Category 6 STP

Table A-1: Transceiver Unit, general specifications

Item	Specification
Frequency range	Voice: 156.000 MHz — 164.000 MHz DSC: 156.525 MHz
Channel spacing	25 kHz, all international maritime channels
Number of P channels	The radio may be programmed with up to 100 private channels in all channel modes.
Modulation	16K0G3E, 16K0G2B (DSC)

Table A-2: Transceiver Unit, detailed specifications

Item	Specification
<b>Transmitter</b>	
RF output power	High: 25 W +0 dB / - 1.5 dB Low: 0.5-1 W
Frequency error	+/- 3ppm
Adjacent channel power	Below 80 dB
Conducted spurious emission	Below 0.25 mW
Distortion	Below 3%
S/N ratio	Better than 46 dB
<b>Receiver @ voice</b>	
Sensitivity	< -119 dBm typically @ 20 dB SINAD CCITT weighted
LF power	Built-in loudspeaker: 6 W (at 5 kHz dev./1 kHz tone) External loudspeaker: 6 W / 8 Ohm
Distortion	Below 5%
Spurious emissions	Below 2 nW
Spurious response rejection	80 dB
Intermodulation response	76 dB
Co-channel rejection	Better than -10 dB
Adjacent channel selectivity	80 dB
Blocking response	Better than 100 dB $\mu$ V @ $\pm$ 1 MHz
<b>Receiver @ DSC</b>	
Sensitivity	-117 dBm
Adjacent channel selectivity	Below 80 dB
Intermodulation response	Better than 70 dB $\mu$ V
Blocking response	Better than 100 dB $\mu$ V

Table A-2: Transceiver Unit, detailed specifications (Continued)

## A.2 SAILOR 7224 Control Unit

Item	Specification
Weight	1.0 kg (2.2 lbs)
Dimensions	<p><b>Height:</b> Outer dimension 107 mm, hole height for flush mount 89 mm</p> <p><b>Width:</b> Outer dimension 241 mm, hole width for flush mount 227 mm</p> <p><b>Depth:</b> Outer dimension from front of knobs 104 mm, depth for flush mount 94 mm</p>
Operating temperature	-15°C to 55°C (5°F to 131°F)
Storage temperature	-25°C to 70°C (-13°F to 158°F)
Ingress Protection	<p>IP54 when flush-mounted (Estimated, only front exposed)</p> <p>IP20 for other installation (whole unit exposed)</p>
Power supply	+24 V DC nom. (-10% / +30%)
Power consumption	<p>10 W @ 24 VDC standby</p> <p>33 W @ 24 VDC max</p>
Heat dissipation	8.5 to 15 W
Display	5.5" TFT with capacitive multi touch – 350 cd/m2. (e.g. 800x600, 1024x768) – 40k hours to half brightness
Speaker	Internal speaker – Max audio output power: 6W (internal LS @ 5 kHz deviation/1kHz)
LAN	<p>2 LAN ports supporting RSTP and 10/100 Mbit</p> <p>1 LAN port not supporting RSTP</p>
USB	USB 2.0
CTRL Port	Supporting up to four SAILOR 6204
ACC Port	Supporting Handset & Hand Microphone. NMEA for GNSS and AIS
AUX Port	Support for VDR, Alarm I/O, GNSS, AUX OC and Ext. Speaker. Max audio output power: 6W (external LS @ 5 kHz deviation/1kHz)
OPT Port	Supporting NMEA RX and TX for BAM support

Table A-3: Control Unit specifications

## A.3 General DSC specifications

Item	Description
DSC operation	According to: - ITU-R M.493.15 - ETSI EN 300 338-1 - ETSI EN 300 338-2
DSC protocol	According to Rec. ITU-R M.493-15 - Class A, IEC 61097-3 and IEC 61097-8
Navigator interface	According to IEC 61162-1 GLL, RMC, ZDA, GGA, VTG, GNS
Modulation	1700 Hz $\pm$ 400 Hz. 1200 baud

Table A-4: General DSC specifications

## A.4 NMEA specifications

The SAILOR 7222 VHF DSC has NMEA inputs/outputs used to communicate with other systems or equipment. These inputs/outputs are connected to the OPT, ACC and AUX connectors on the Control Unit. See description in *Connectors on the SAILOR 7224 Control Unit* on page 2-10.

Item	Specification
Rx sentences	ACN, HBT, GGA, GLL, GNS RMC, ZDA.
Tx sentences	ALC, ALF, ARC, HBT.
Talker ID	CV
Supported standards	IEC 61162-1, 2016 Edition 5
Baud rate	4800
Electrical Isolation	1000 VDC
Load of each input	Max. 2 mA
Input impedance	100 Ohm
Max number of listeners	20 listeners/each 2 mA/ >60 Ohm
Tx interval	Default 30 seconds for HBT

Table A-5: NMEA specifications

## A.4.1 NMEA interface description

NMEA is used in both the ACC connector, the AUX connector and the OPT connector. The NMEA interface is described below.

(Extract from IEC 61162-1)

- NMEA + and - are indicated in the connector descriptions for ACC, AUX and OPT in the section *Connectors on the SAILOR 7224 Control Unit* on page 2-10.
- Max output drive is 40 mA.
- A list of supported sentences and data fields are given in Appendix B, *NMEA sentences*.
- Load of the input circuit is max. 2 mA.
- Compliance with IEC61162-1 (5th ed.).

**NMEA output:** U903 is a ISL32452E which is an RS-485/RS-422 transceiver. In this circuit it is only used as a transmitter.

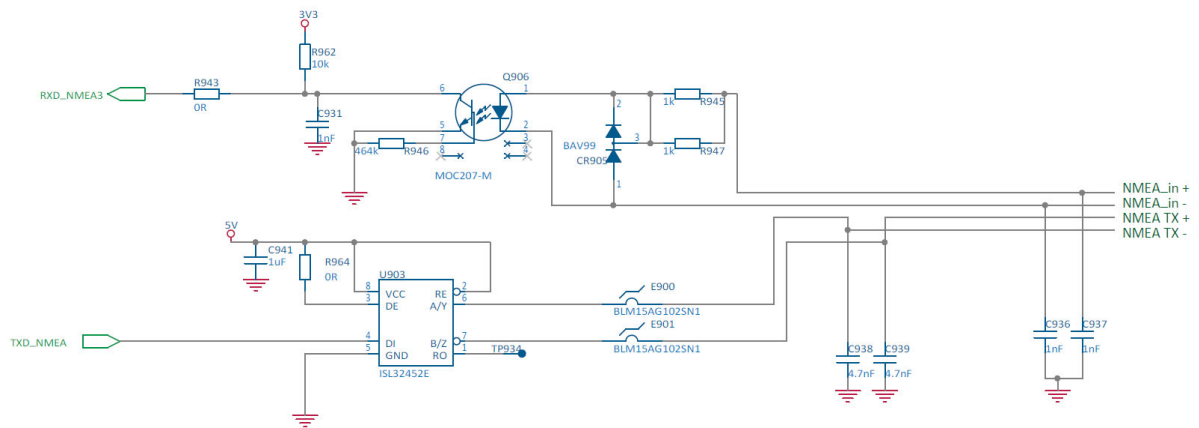

Figure A-1: NMEA interface description

## A.4.2 List of BAM alerts

The table below shows the alerts you may see in the Bridge Alert Management (BAM) system.

ID	Instance	Priority	Category	Title	Description
3023	1	C	B	PS COMM Lost	Power supply communication lost
3023	2	C	B	BATT VOLT Low	Battery and charger. Voltage below limit
3023	3	C	B	BATT VOLT High	Battery and charger. Voltage above limit
3078	1	W	B	Printer Status	No connection to printer
3016	1	C	B	SAR-POSITION LOST	No position available
3016	2	C	B	SAR-POSITION LOST	No position available for 10 minutes
3013	1	C	B	POSN 4hrs Old	Position more than 4 hrs old
3013	2	C	B	POSN 23,5hrs Old	Position more than 23,5 hrs old
3122	Dynamic <sup>a</sup>	W	B	DISTRESS: RX	Incoming distress
3122	Dynamic <sup>a</sup>	W	B	DISTRESS: RELAY	Incoming distress relay
3122	Dynamic <sup>a</sup>	W	B	URGENCY: RX	Incoming urgency call
3123	Dynamic <sup>a</sup>	C	B	SAFETY: COM	Incoming safety call
3123	Dynamic <sup>a</sup>	C	B	SAFETY: POS	Incoming safety pos. call
3123	Dynamic <sup>a</sup>	C	B	SAFETY: TEST	Incoming safety test call
3123	Dynamic <sup>a</sup>	C	B	ROUTINE: COM	Incoming routine call
3123	Dynamic <sup>a</sup>	C	B	ROUTINE: POLL	Incoming routine poll
3123	Dynamic <sup>a</sup>	c	B	GROUP: RX	Incoming group call
3008	1	w	B	TX POWER:INHIBIT	Transmission inhibited
	1	w	B	TU Conn Lost	TU connection lost. Verify connection

Table A-6: List of alerts

- a. Alert instance is assigned according to IEC61162-1:2016, 8.3.13, 9).

All warnings are repeated as warnings for each 4 minutes, i.e. silent period will maximum be 4 minutes. Responsibility transfer can only occur for warning alert in BAM Category “B” and only via incoming NMEA command from e.g. a CAM.

# NMEA sentences

## B.1 NMEA sentences used

All sentences are defined according to IEC 61162-1 edition 5.0 and IEC 61162-450 edition 2.0.

### B.1.1 Light weight Ethernet - LWE

Sentences may be configured to be received and transmitted over serial ACC, AUX and OPT interfaces, but also over Light Weight Ethernet (IEC 61162-450). The following table shows the available transmission group multicast addresses and ports that can be set up in the user interface.

Transmission group	Category	Multicast address	Destination port
MISC	SF not explicitly listed below	239.192.0.1	60001
TGTD	Target data (AIS), tracked target messages (Radar)	239.192.0.2	60002
SATD	High update rate, for example ship heading, attitude data.	239.192.0.3	60003
NAVD	Navigational output other than that of TGTD and SATD groups	239.192.0.4	60004
VDRD	Data required for the VDR according to IEC 61996	239.192.0.5	60005
RCOM	Radio communication equipment	239.192.0.6	60006
TIME	Time transmitting equipment	239.192.0.7	60007
PROP	Proprietary and user specified SFs	239.192.0.8	60008
USR1 to USR8	User defined transmission group 1 to 8	239.192.0.9 to 239.192.0.16	60009 to 60016
BAM1 to BAM2	BAM compliant alert source reporting to CAM	239.192.0.17 to 239.192.0.18	60017 to 60018
CAM1 to CAM2	CAM of the BAM	239.192.0.19 to 239.192.0.20	60019 to 60020

Table B-1: Multicast addresses and ports for LWE transmission groups



Transmission group	Category	Multicast address	Destination port
NETA	Network administration	239.192.0.56	60056
PGP1 to PGP4	Primary PGN Group 1 to PGN Group 4	239.192.0.57 to 239.192.0.60	60057 to 60060
PGB1 to PGB4	Backup PGN Group 1 to PGN Group 4	239.192.0.61 to 239.192.0.64	60061 to 60064

Table B-1: Multicast addresses and ports for LWE transmission groups (Continued)

## B.1.2 Sentence characteristics and their linkage with port configuration

The following table lists all the supported sentences. The Interface column reflects the group of sentences that can be configured for a specific port.

Transmission Interval indicates the time after which a renewed sentence must be received. Otherwise sentence data will be invalidated.

Interface	Sentence	Transmission Interval (s)	
		Maximum	Recommended
GNSS input sentences	GGA	5	1
	GLL	5	1
	GNS	5	1
	RMC	5	1
	ZDA	5	1
Alarm output sentences	ALC	30 (required)	
	ALF	-	
	ARC	-	
	HBT	30 (required)	
Alarm input sentences	ACN	-	

Table B-2: Supported sentences

### B.1.3 Maximum data rates

The maximum data rate for receiving NMEA – LWE sentences is 64 kbit/s. This equals 51 datagrams per second.

The maximum data rate for incoming Ethernet traffic - addressed or broadcast - not used by the device is 0.9 Mbit/s. This equals 737 datagrams per seconds.

The system can handle 711 datagrams per second of type b) datagrams, while handling a 50% load of type a) datagrams.

**Note** | The assumption is that a standard NMEA – LWE datagram is 160 byte long including UDP head, LWE header and NMEA sentence. 1kbit = 1024bit and 1Mbit = 1024\*1024bit

### B.1.4 Other network functionality

#### Input:

Protocol	Usage	Notes
LWE	500 bit/s	Position/Time/BAM
HTTP/MQTT	5 kbit/s	Control
HTTP/MQTT	2 kbit/s	External UI
SIP, RSTP, RTCP	500 kbit/s	Audio between SAILOR 7224 Control Unit and SAILOR 7226 VHF Transceiver Unit
RSTP	300 bit/s	Only ring network
NTP	30 bit/s	Time sync
SNMP, SLP, ZeroConf, DHCP, mDNS	1 kbit/s	For ThraneLINK

Table B-3: Other network functionality, input

#### Output:

Protocol	Usage	Notes
LWE	500 bit/s	BAM
HTTP/MQTT	5 kbit/s	Control
MQTT	2 kbit/s	External UI
SIP, RSTP, RTCP	500 kbit/s	Audio
RSTP	500 bit/s	Only ring network
NTP	30 bit/s	Time sync
SNMP, SLP, ZeroConf, DHCP, mDNS	1 kbit/s	For ThraneLINK, Printers

Table B-4: Other network functionality, output

## B.2 Sentence use reference

This section describes the supported sentences and the specific field use in the SAILOR 7222 VHF DSC.

### B.2.1 Overview of supported sentences

- *ACN - Alert command (input)*
- *ALC - Cyclic alert list (output)*
- *ALF - Alert sentence (output)*
- *ARC - Alert Command refused*
- *GGA - Global positioning system (GPS) fix data*
- *GLL - Geographic position - Latitude/longitude (output)*
- *GNS - Fix data (input)*
- *HBT - Heartbeat supervision sentence (input)*
- *RMC - Recommended minimum specific GNSS data (input)*
- *ZDA - Time and Date (output)*

### B.2.2 ACN - Alert command (input)

\$--ACN, hhmmss.ss,aaa,x.x,x.x,c,a\*hh<CR><LF>

Field	Data format	Description	Comment
1	ACN	Sentence Id	Used
2	hhmmss.ss	Time	Used
3	aaa	Manufacturer mnemonic code	Used
4	x.x	Alert identifier	Used
5	x.x	Alert instance, 1- 999999	Used
6	c	Alert command, A, Q, O or S	Used
7	a	Sentence status flag	Used

Table B-5: ACN - Alert command (input)

### B.2.3 ALC - Cyclic alert list (output)

\$--ALC, xx,xx,xx,x.x,aaa,x.x,x.x,x.x,.....,aaa,x.x,x.x,x.x\*hh<CR><LF>

Field	Data format	Description	Comment
1	ALC	Sentence Id	Used
2	xx	Total number of sentences for this message, 01 to 99	Used
3	xx	Sentence number, 01 to 99	Used
4	xx	Sequential message identifier, 00 to 99	Used
5	x.x	Number of alert entries	Used
6	aaa	Manufacturer mnemonic code	Used
7	x.x	Alert identifier	Used
8	x.x	Alert instance	Used
9	x.x	Revision counter	Used

Table B-6: ALC - Cyclic alert list (output)

Fields 6 to 9 can have multiple occurrences.

### B.2.4 ALF - Alert sentence (output)

\$--ALF, x,x,x,hhmmss.ss,a,a,a,aaa,x.x,x.x,x.x,x,c---c\*hh<CR><LF>

Field	Data format	Description	Comment
1	ALF	Sentence Id	Used
2	x	Total number of ALF sentences for this message	Used
3	x	Sentence number, 1 to 2	Used
4	x	Sequential message identifier, 0 to 9	Used
5	hhmmss.ss	Time of last change	Used
6	a	Alert category, A, B or C	Used
7	a	Alert priority, E, A, W or C	Used
8	a	Alert state, A, S, N, O, U or V	Used
9	aaa	Manufacturer mnemonic code	Used
10	x.x	Alert identifier	Used
11	x.x	Alert instance, 1 to 999999	Used

Table B-7: ALF - Alert sentence (output)

Field	Data format	Description	Comment
12	x.x	Revision counter, 1 to 99	Used
13	x	Escalation counter	Used
14	c---c	Alert text	Used

Table B-7: ALF - Alert sentence (output) (Continued)

## B.2.5 ARC - Alert Command refused

\$CSARC,hhmmss.ss,aaa,x.x,x.x,c\*hh<CR><LF>

Field	Data format	Description	Comment
1	ARC	Sentence Id	Used
2	hhmmss.ss	Time	Not used
3	aaa	Manufacturer mnemonic code	Not used
4	x.x	Alert identifier	Used
5	x.x	Alert instance, 1 to 999999	Used
6	c	Refused alert command, A, Q, O or S	Used

Table B-8: ARC sentence - Alert Command Refused

## B.2.6 GGA - Global positioning system (GPS) fix data

\$--GGA, hhmmss.ss, llll.ll, a, yyyyy.yy, a, x, xx, x.x, x.x, M, x.x, M, x.x, xxx\*hh<CR><LF>

Field	Data format	Description	Comment
1	GGA	Sentence ID	Used
2	hhmmss.ss	UTC of position	Used
3	llll.ll	Latitude, N/S	Used
4	a	Latitude, N/S	Used
5	yyyyy.yy	Longitude, E/W	Used
6	a	Longitude, E/W	Used
7	x	GPS quality indicator	Used
8	xx	Number of satellites in use, 00-12 (may be different from the number in view)	Not used
9	x.x	Horizontal dilution of precision	Not used
10	x.x	Antenna altitude above/below	Not used

Table B-9: GGA sentence - Global positioning system (GPS) fix data

Field	Data format	Description	Comment
11	M	Units of antenna altitude, m	Not used
12	x.x	Geoidal separation	Not used
13	M	Units of geoidal separation, m	Not used
14	x.x	Age of differential GPS data	Not used
15	xxxx	Differential reference station ID, 0000-1023	Not used

Table B-9: GGA sentence - Global positioning system (GPS) fix data

## B.2.7 GLL - Geographic position - Latitude/longitude (output)

\$GPGLL, llll.ll, a, yyyyy.yy, a, hhmmss.ss, A, a \*hh<CR><LF>

Field	Data format	Description	Comment
1	GLL	Sentence ID	Used
2	llll.ll	Latitude, N/S	Used
3	a	Latitude, N/S	Used
4	yyyyy.yy	Longitude, E/W	Used
5	a	Longitude, E/W	Used
6	hhmmss.ss	UTC of position	Used
7	A	Status. A=data valid V=data invalid	Used
8	a	Mode Indicator	Used

Table B-10: GLL sentence - Geographic position (output)

## B.2.8 GNS - Fix data (input)

\$--GNS, hhmmss.ss, llll.ll, a, yyyyy.yy, a, c-c, xx, x.x, x.x, x.x, x.x, x.x, a \*hh<CR><LF>

Field	Data format	Description	Comment
1	GNS	Sentence Id	Used
2	hhmmss.ss	UTC of position	Used
3	llll.ll	Latitude	Used
4	a	Latitude N/S	Used
5	yyyyy.yy	Longitude	Used

Table B-11: GNS sentence - Fix data (input)

Field	Data format	Description	Comment
6	a	Longitude E/W	Used
7	c-c	Mode indicator	Used
8	xx	Total number of satellites in use, 00-99	Not Used
9	x.x	HDOP	Not Used
10	x.x	Antenna altitude, m	Not Used
11	x.x	Geoidal separation	Not Used
12	x.x	Age of differential data	Not Used
13	x.x	Differential reference station	Not Used
14	a	Navigational status indicator	Used

Table B-11: GNS sentence - Fix data (input)

## B.2.9 HBT - Heartbeat supervision sentence (input)

\$--HBT,x.x,a,x\*hh<CR><LF>

Field	Data format	Description	Comment
1	HBT	Sentence Id	Used
2	x.x	Configured repeat interval	Used
3	a	Equipment status	Used
4	x	Sequential sentence identifier	Used

Table B-12: HBT sentence - Heartbeat supervision sentence (input)

## B.2.10 RMC - Recommended minimum specific GNSS data (input)

\$--RMC, hhmmss.ss,a,IIII.II,a,yyyyy.yy,a ,x.x,x.x, xxxxxx, x.x,a,a\*hh<CR><LF>

Field	Data format	Description	Comment
1	RMC	Sentence Id	Used
2	hhmmss.ss	UTC of position fix	Used
3	a	Status (A or V)	Used
4	IIII.II	Latitude	Used
5	a	Latitude N/S	Used
6	yyyyy.yy	Longitude	Used
7	a	Longitude E/W	Used

Table B-13: RMC sentence - Recommended minimum specific GNSS data (input)

Field	Data format	Description	Comment
8	x.x	Speed over ground, knots	Used
9	x.x	Course over ground, degrees true	Used
10	xxxxxx	Date: ddmmyy	Used
11	x.x	Magnetic variation, degrees	Not Used
12	a	Magnetic variation, E/W	Not Used
13	a	Mode indicator	Used
14	a	Navigational status	Used

Table B-13: RMC sentence - Recommended minimum specific GNSS data (input)

RMC-sentences older than NMEA Version 2.3 do not contain the Mode-Indicator field. For the VHF radio to fully support these old RMC-sentences the GNSS must also send GGA-sentences.

### B.2.11 ZDA - Time and Date (output)

\$--ZDA, hhmmss.ss,xx,xx,xxxx,xx,xx\*hh<CR><LF>

Field	Data format	Description	Comment
1	ZDA	Sentence Id	Used
2	hhmmss.ss	UTC	Used
3	xx	Day, 01 to 31 (UTC)	Used
4	xx	Month, 01 to 12 (UTC)	Used
5	xxxx	Year (UTC)	Used
6	xx	Local zone hours (00 to +/-13h)	Not Used
7	xx	Local zone minutes (00 to +59)	Not Used

Table B-14: ZDA sentence - Time and Date (output)



# System configurations

This appendix lists selected examples of system configurations.

For an overview and specifications of the cables needed see **Cable requirements** on page C-17.

**Note**

For installation of the connection boxes see *Connection box SAILOR 6207* on page 2-23, *Connection box SAILOR 6208* on page 2-25 and *Connection box SAILOR 6209* on page 2-27.

## C.1 System configuration examples

The following list shows system configurations, with additional handsets, alarm panels, connection boxes and cable information.

1. *How to connect a SAILOR N163S AC Power Supply*
2. *How to install an extra SAILOR 6201, GNSS, ext. loudspeaker and alarm equipment*
3. *How to install a GNSS and SAILOR 6270 External loudspeaker*
4. *How to install 2 extra SAILOR 6201 Handsets and a GNSS*
5. *How to install a CAN bus with a SAILOR 6204 CSM close to the VHF radio*
6. *How to install a CAN bus with a SAILOR 6204 CSM not close to the VHF radio*
7. *How to install a CAN bus with a SAILOR 6204 CSM far from the VHF radio*
8. *How to install a CAN bus with 2 SAILOR 6204 CSMs far from the VHF radio*
9. *How to install a CAN bus with 2 SAILOR 6204 CSMs close to VHF on a small bridge*
10. *How to install a CAN bus with 2 CSMs in bridge wings*
11. *How to install a CAN bus with 3 SAILOR 6204 CSMs*
12. *How to install a CAN bus with 4 SAILOR 6204 CSMs*
13. *How to install LAN*
14. *How to install a Central Alert Management (CAM) system*
15. *How to install a printer*

### C.1.1 How to connect a SAILOR N163S AC Power Supply

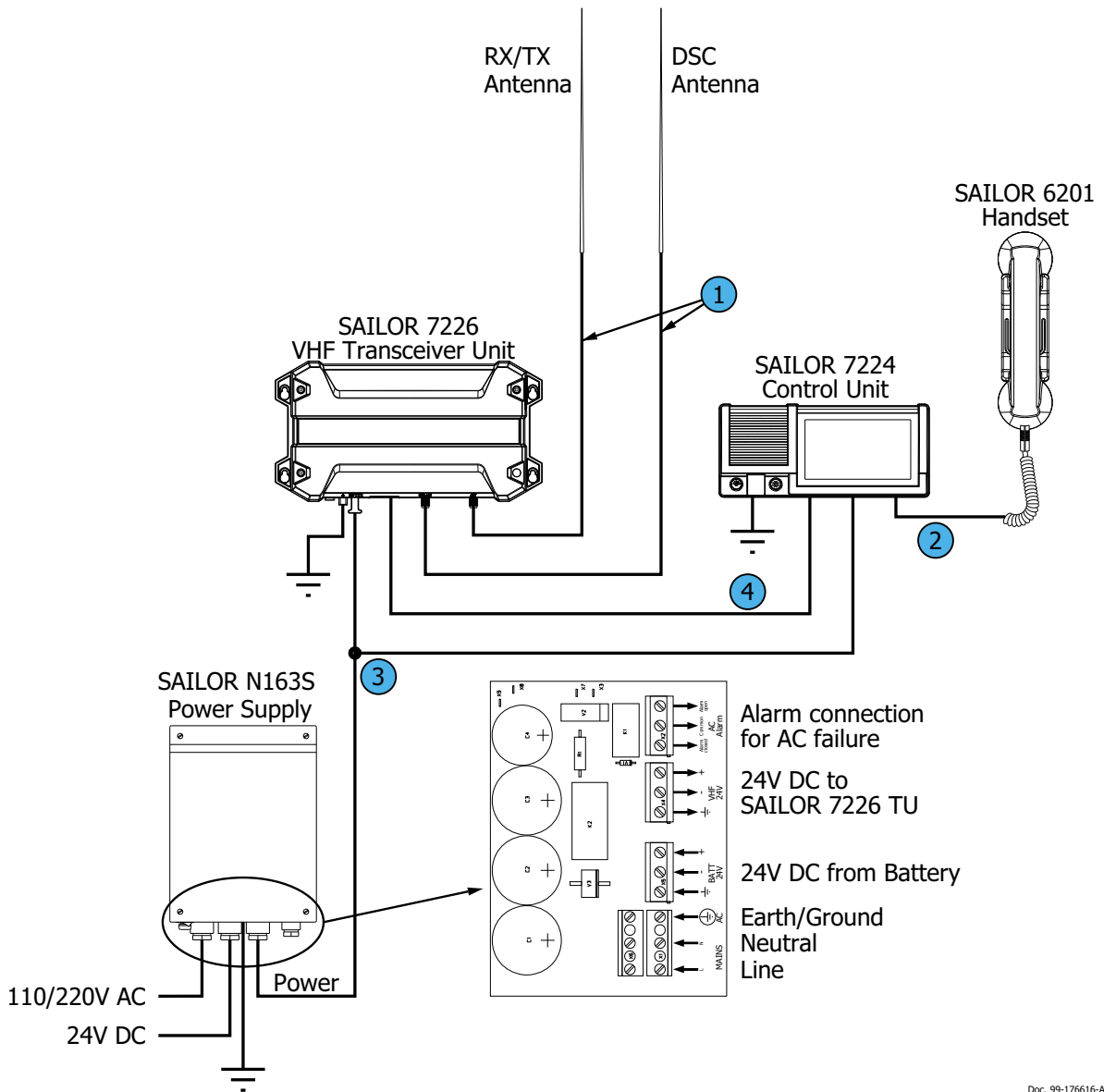

Doc. 99-176616-A

Figure C-1: System configuration, SAILOR N163S Power Supply

## C.1.2 How to install an extra SAILOR 6201, GNSS, ext. loudspeaker and alarm equipment

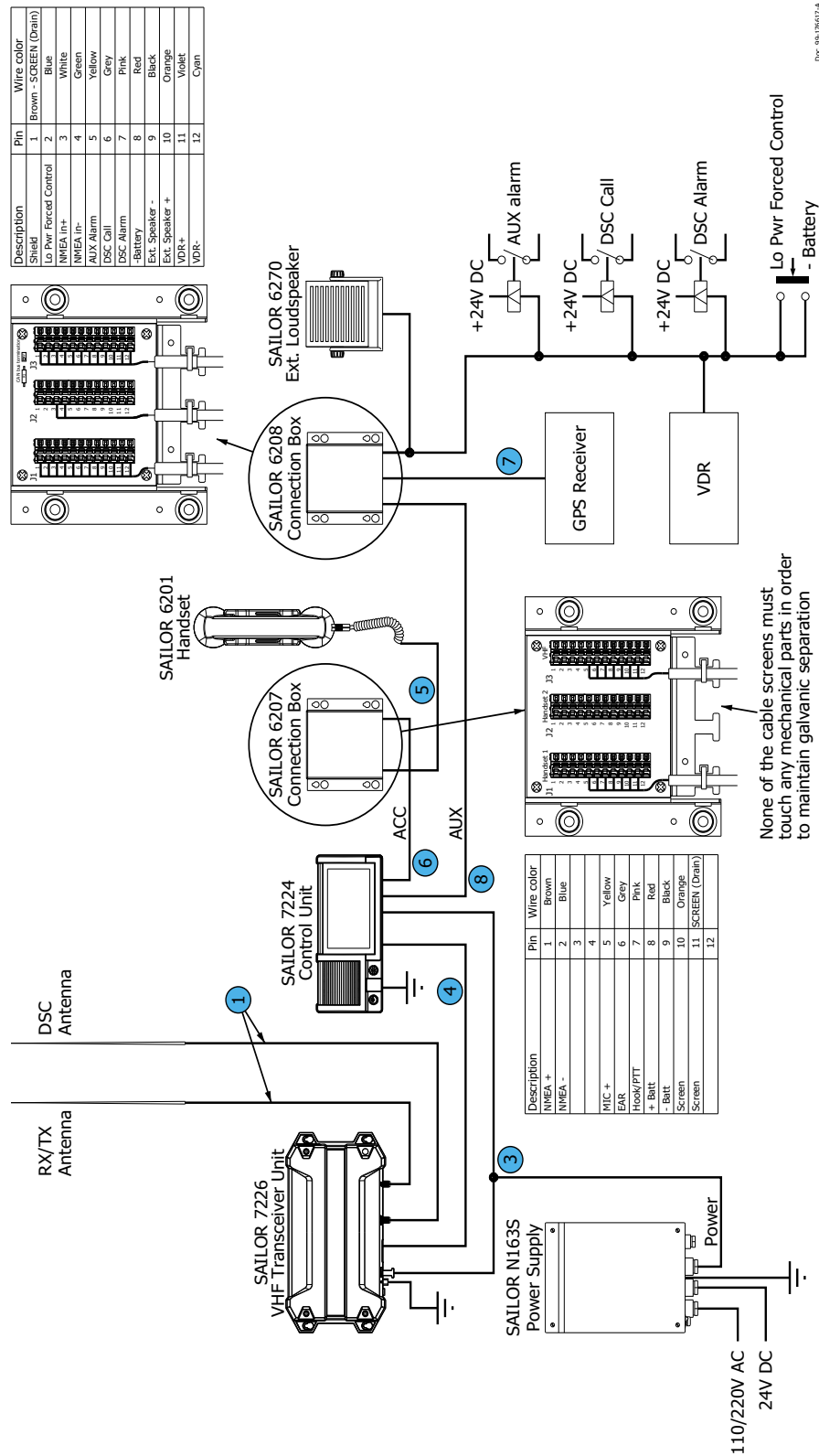
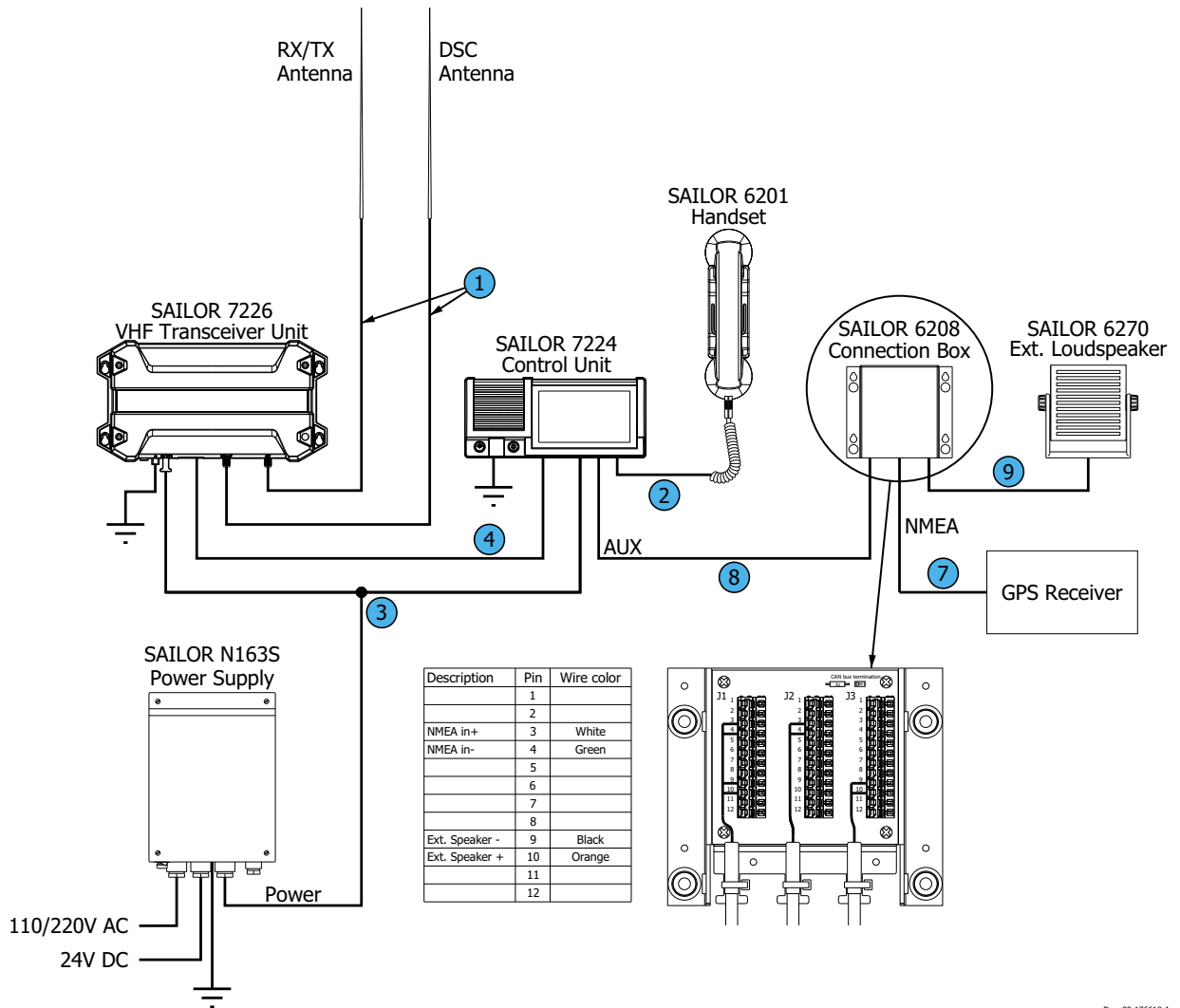

Figure C-2: System configuration, SAILOR 6201, GNSS, ext. loudspeaker and alarms

### C.1.3 How to install a GNSS and SAILOR 6270 External loudspeaker



Doc: 99-176618-A

Figure C-3: System configuration, GNSS and SAILOR 6270 External loudspeaker

### C.1.4 How to install 2 extra SAILOR 6201 Handsets and a GNSS

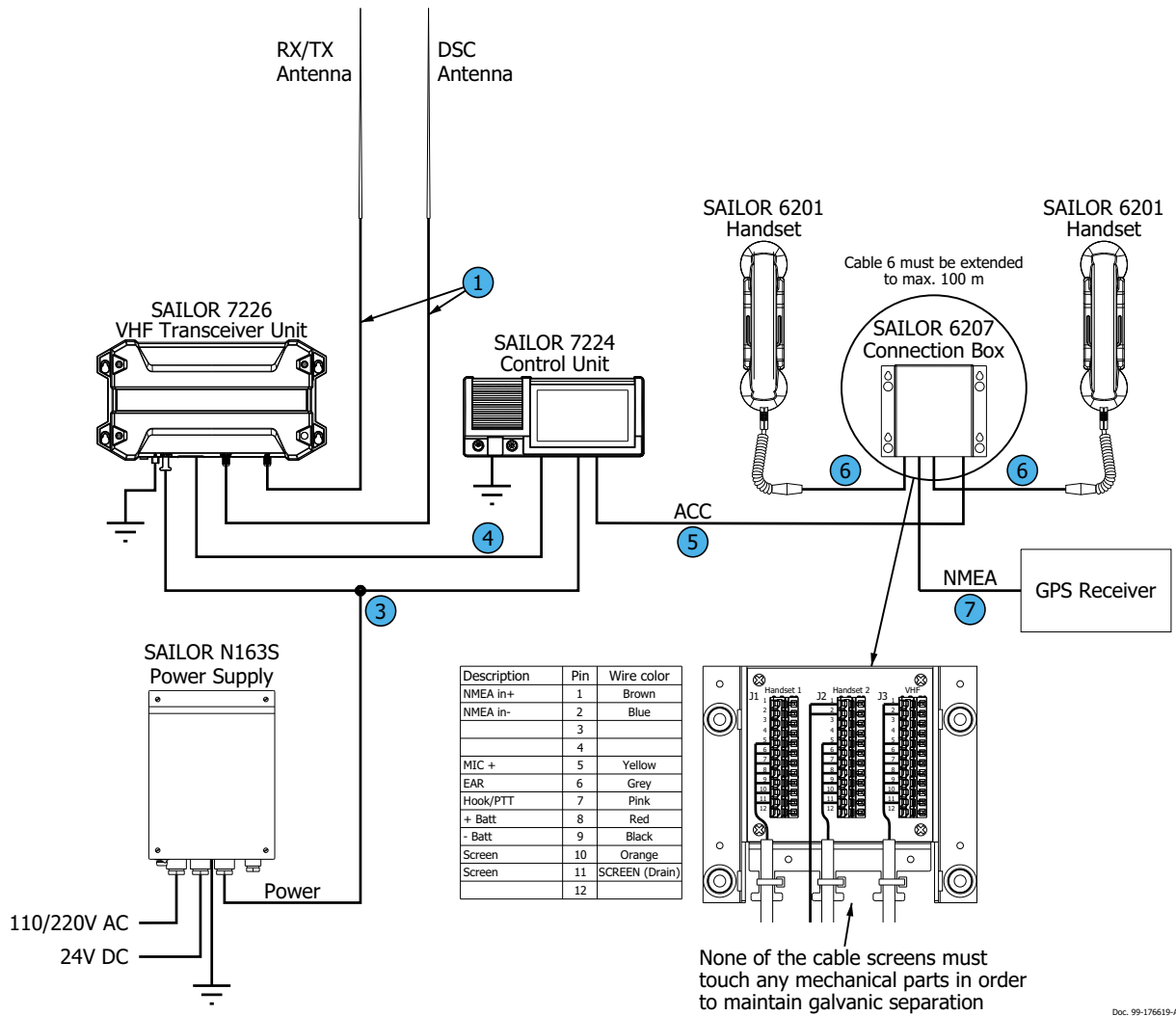
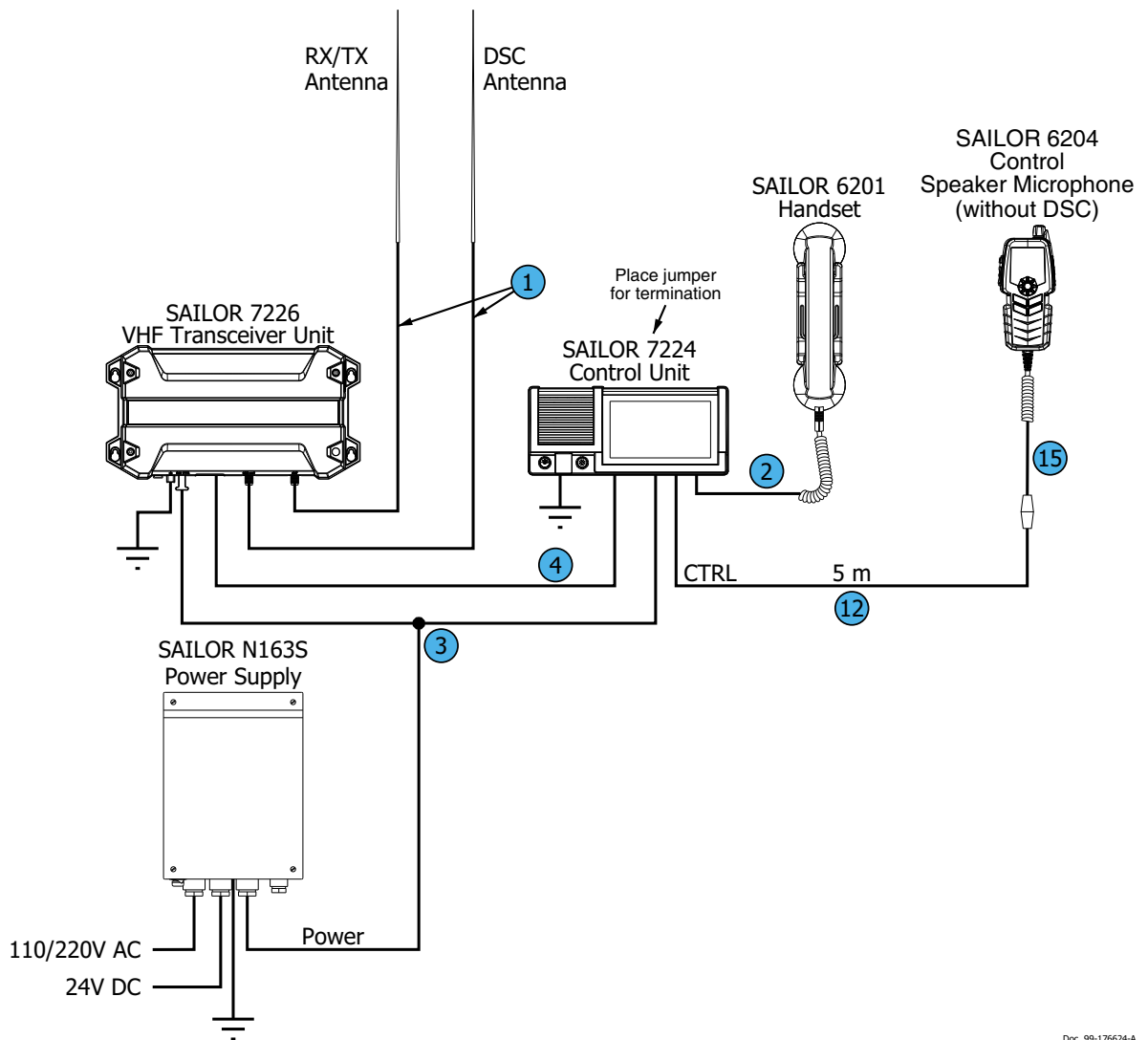

Figure C-4: System configurations, 2 SAILOR 6201 Handsets and a GNSS

### C.1.5 How to install a CAN bus with a SAILOR 6204 CSM close to the VHF radio



Doc. 99-176624-A

Figure C-5: System configuration, CAN bus, SAILOR 6204 CSM, close to the VHF radio

### C.1.6 How to install a CAN bus with a SAILOR 6204 CSM not close to the VHF radio

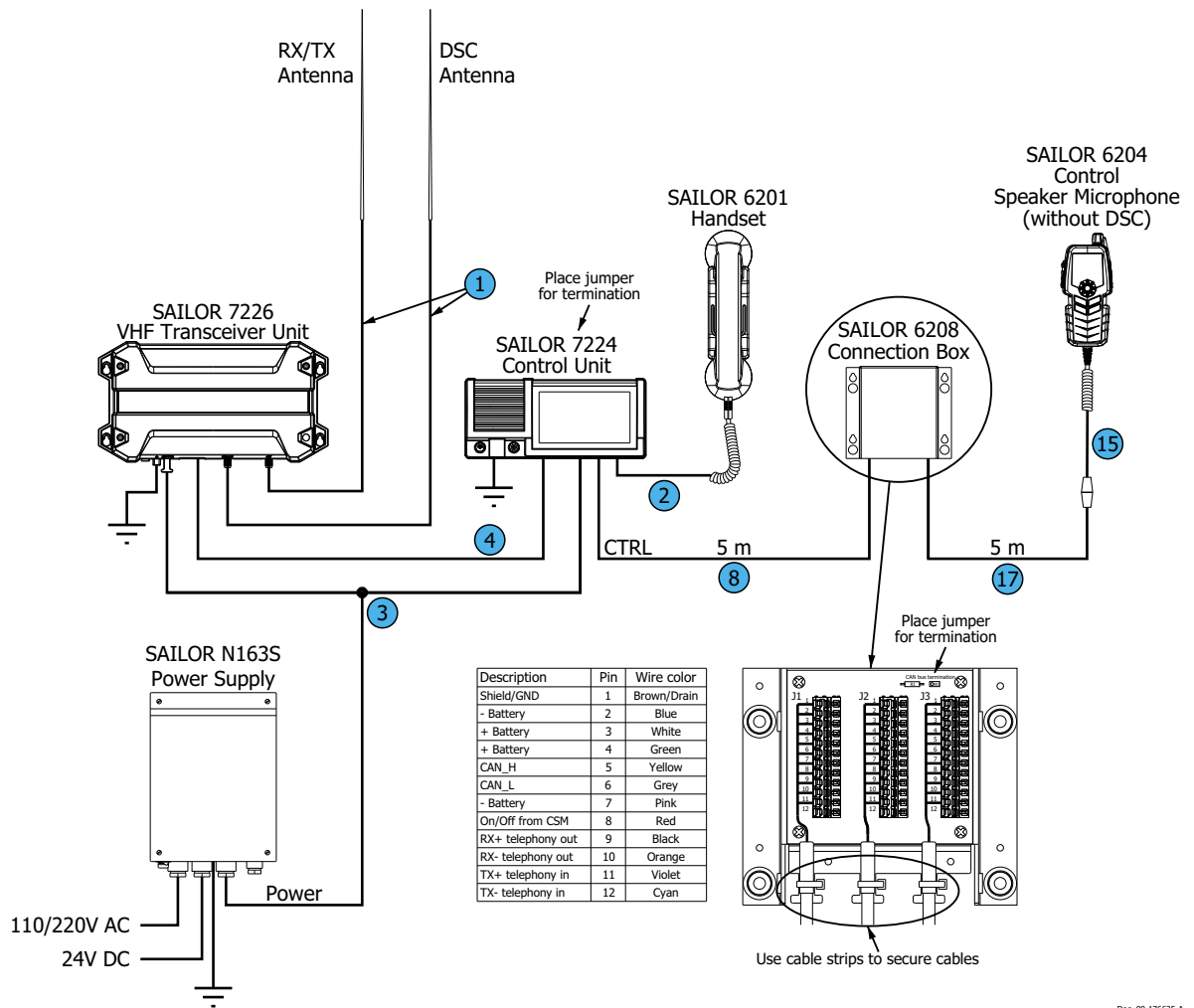

Doc. 99-176625-A

Figure C-6: System configuration, CAN bus, SAILOR 6204 CSM, not close to the VHF radio

### C.1.7 How to install a CAN bus with a SAILOR 6204 CSM far from the VHF radio

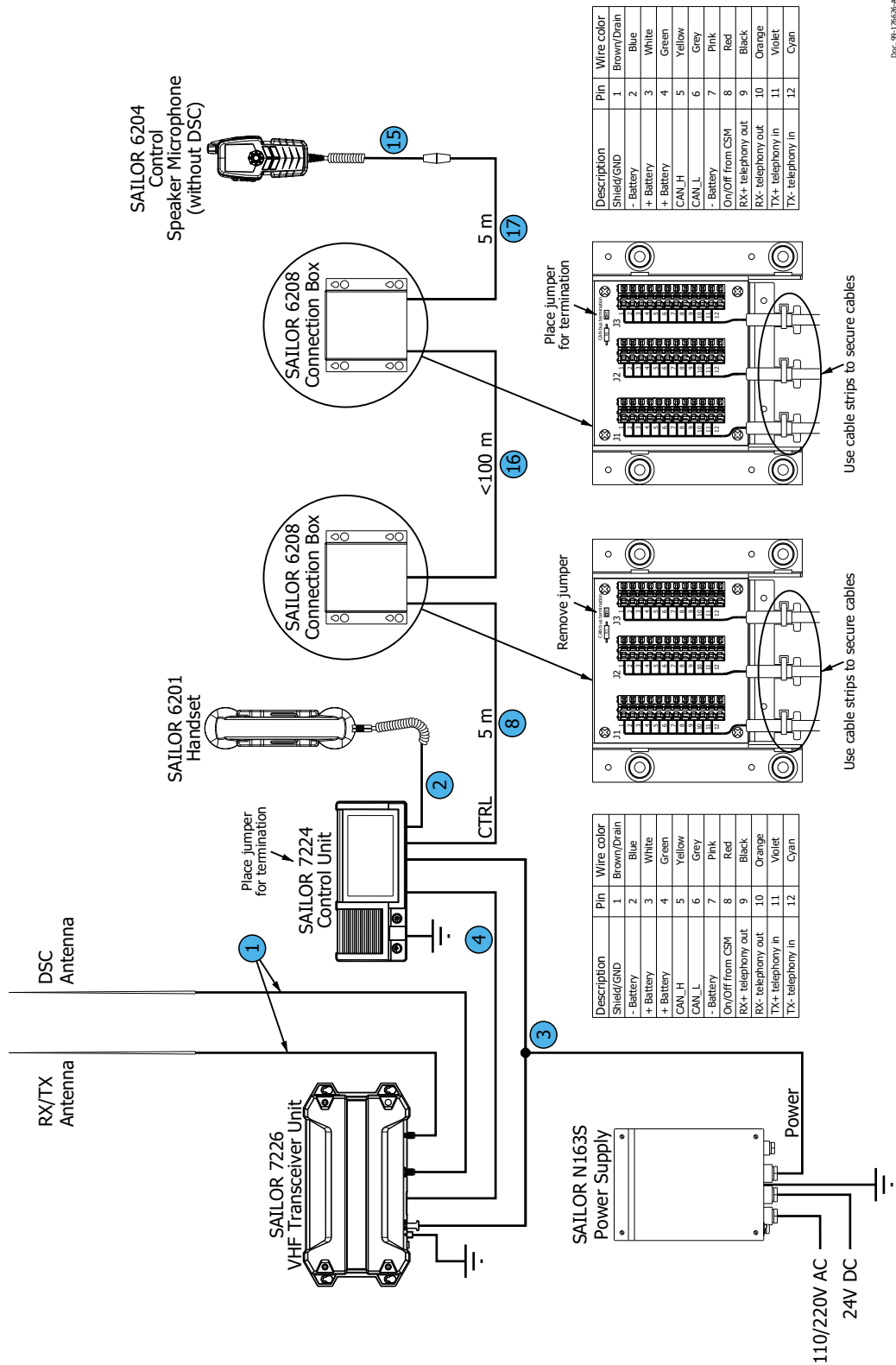

Doc. 99-17628-A

Figure C-7: System configuration, CAN bus, SAILOR 6204 CSM, far from the VHF radio



### C.1.8 How to install a CAN bus with 2 SAILOR 6204 CSMs far from the VHF radio

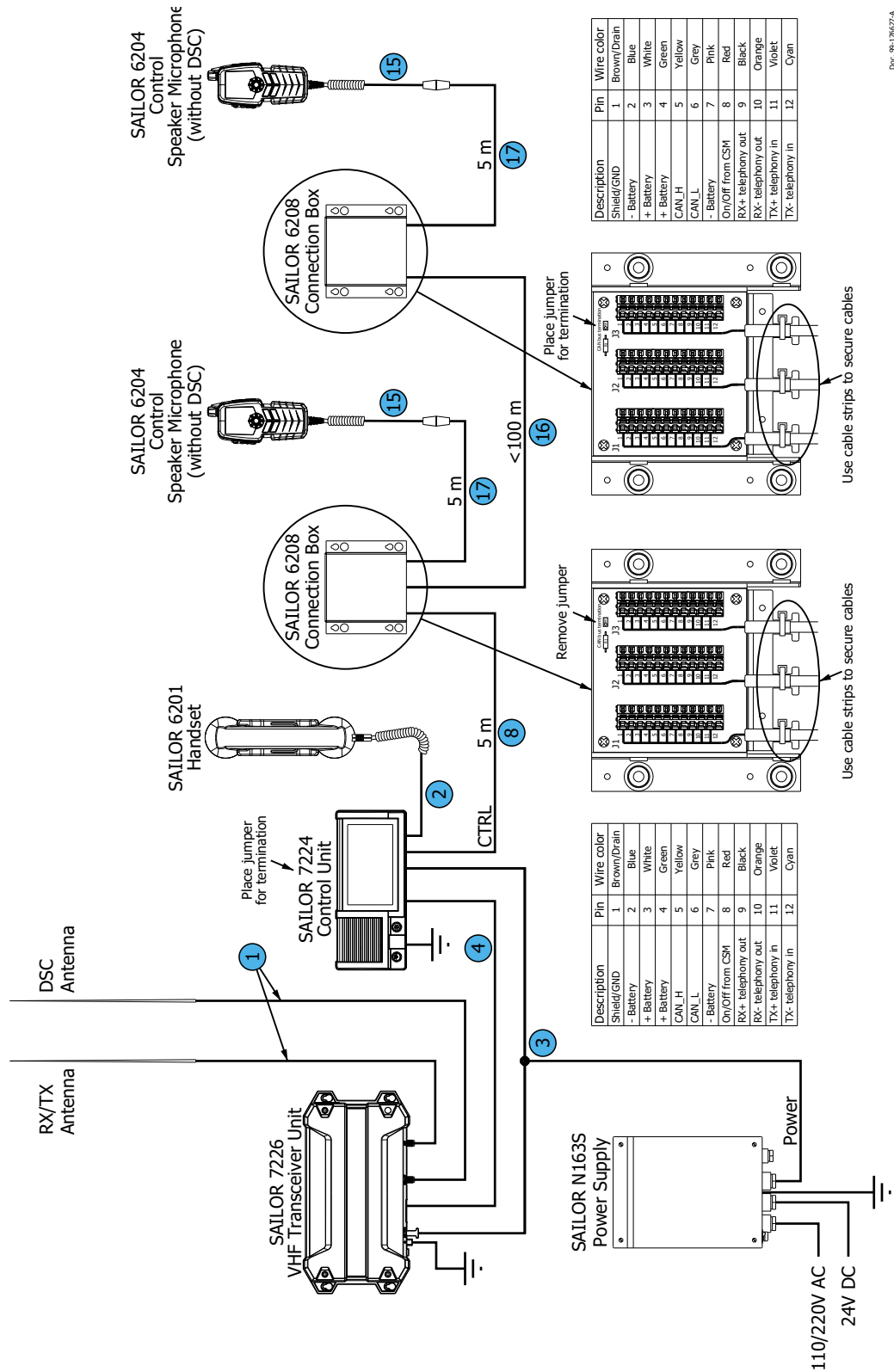

Doc: 99-17627-A

Figure C-8: System configuration: CAN bus, 2 SAILOR 6204 CSMs, far from VHF radio

### C.1.9 How to install a CAN bus with 2 SAILOR 6204 CSMs close to VHF on a small bridge

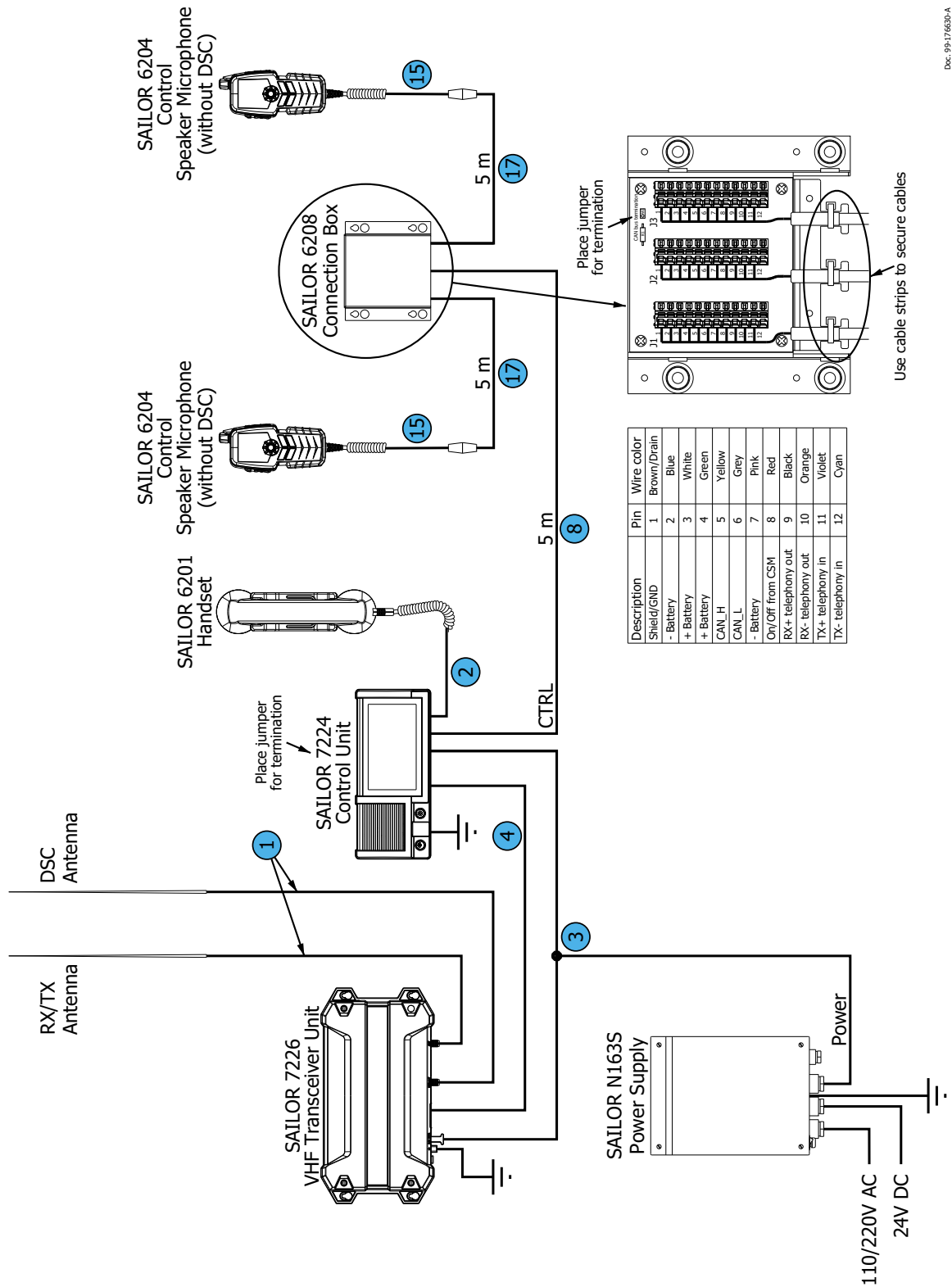

Doc. 99-176630-A

Figure C-9: System configuration: CAN bus, 2 SAILOR 6204 CSMs, close VHF, small bridge

### C.1.10 How to install a CAN bus with 2 CSMs in bridge wings

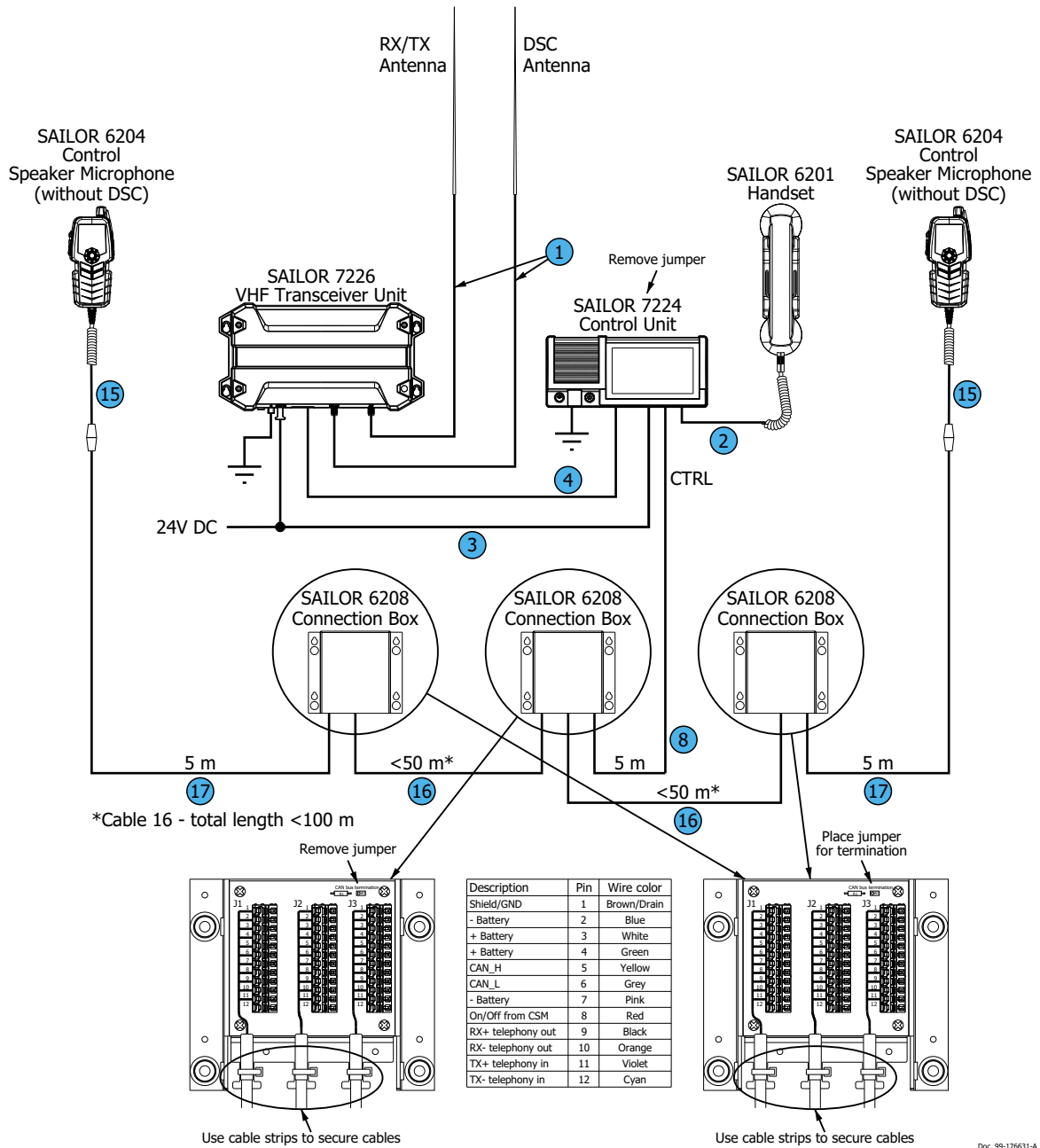

Doc. 99-176631-A

Figure C-10: System configuration: CAN bus, 2 SAILOR 6204 CSMs, in bridge wings

### C.1.11 How to install a CAN bus with 3 SAILOR 6204 CSMs

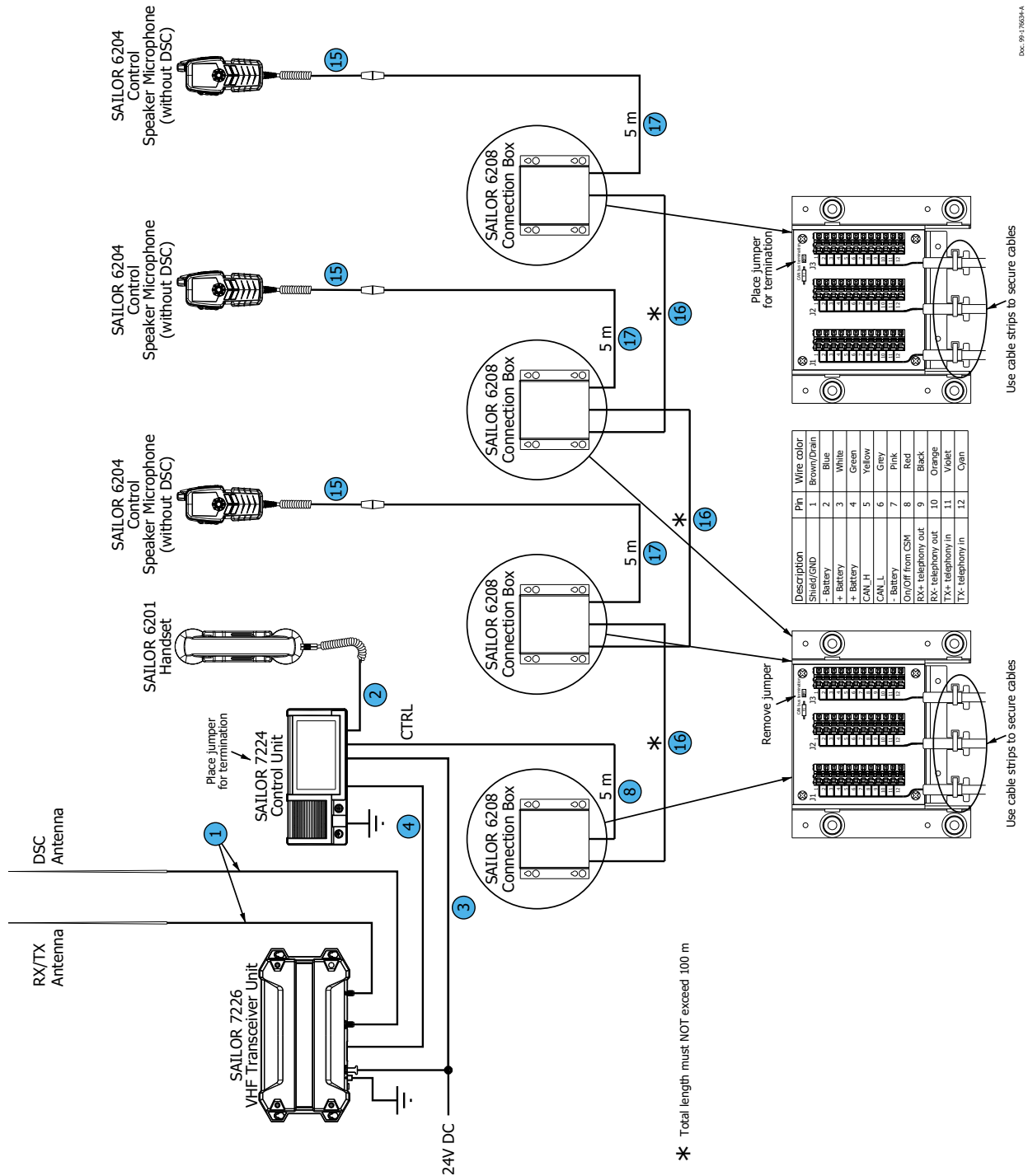

Doc. 99-17603A

Figure C-11: System configuration: CAN bus, 3 SAILOR 6204 CSMs

### C.1.12 How to install a CAN bus with 4 SAILOR 6204 CSMs

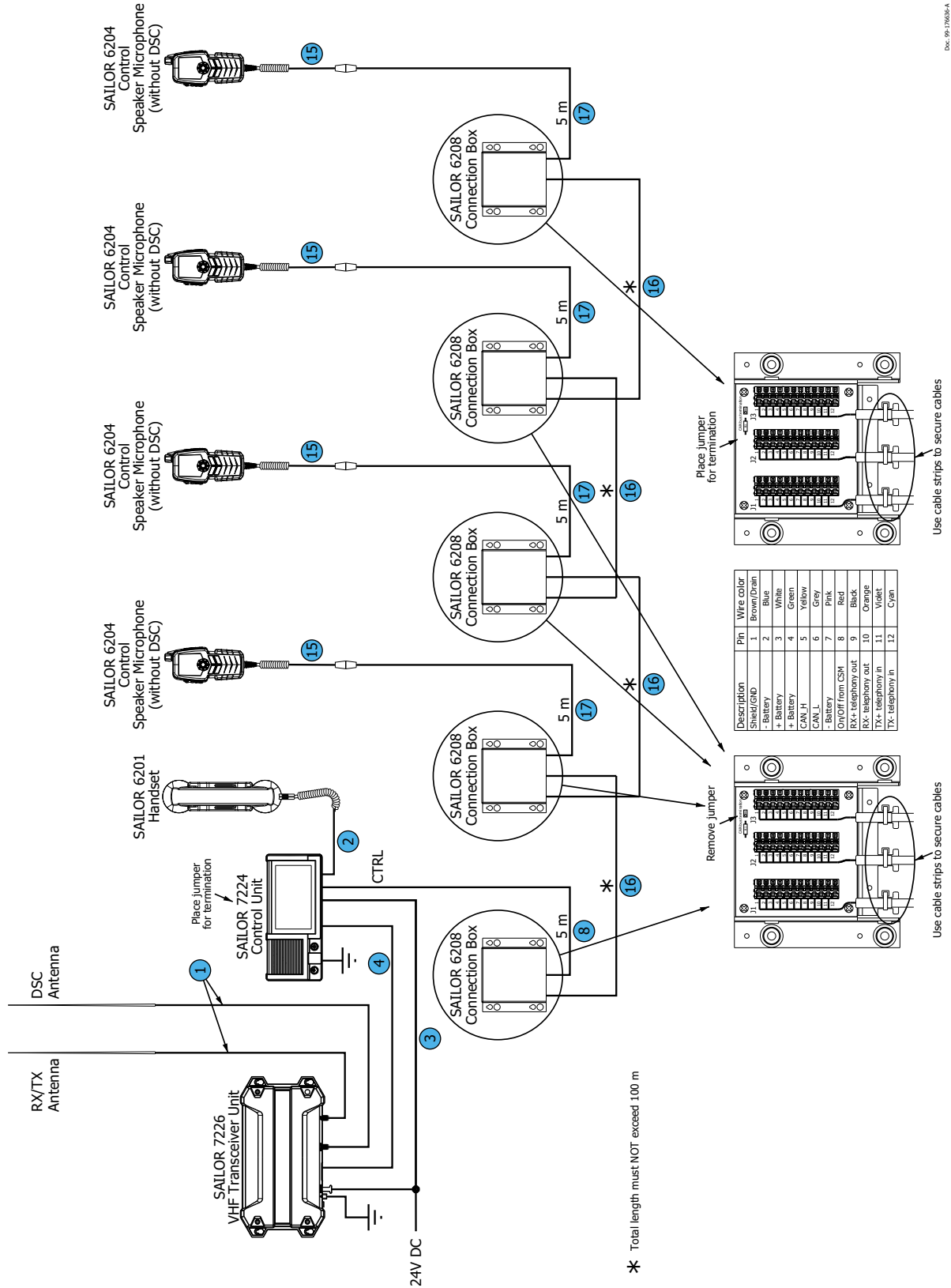

Doc. 98-171833-A

Figure C-12: System configuration: CAN bus, 4 SAILOR 6204 CSMs

### C.1.13 How to install LAN

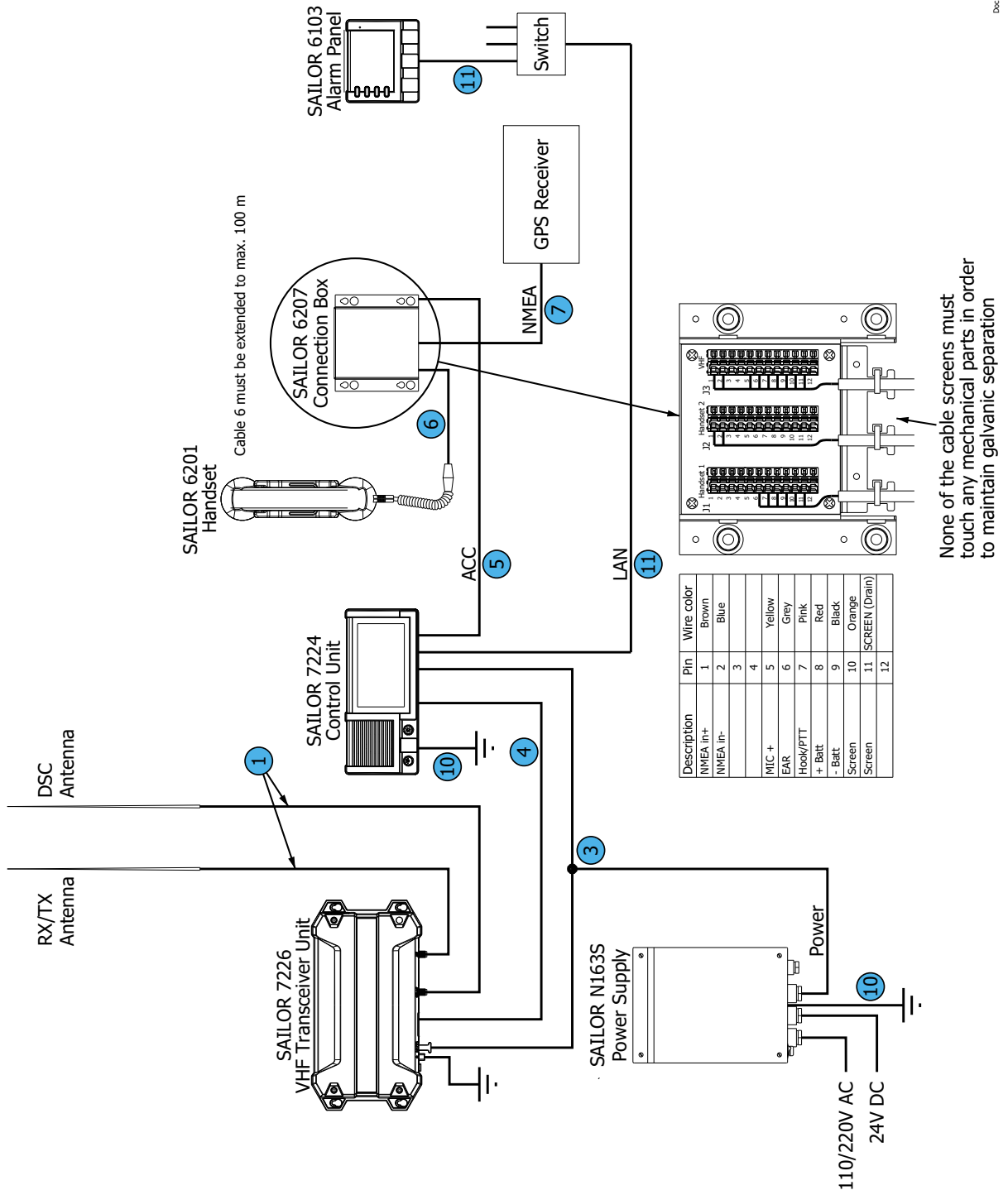

Doc: 98-17637-A

Figure C-13: System configuration: Installation of LAN

### C.1.14 How to install a Central Alert Management (CAM) system

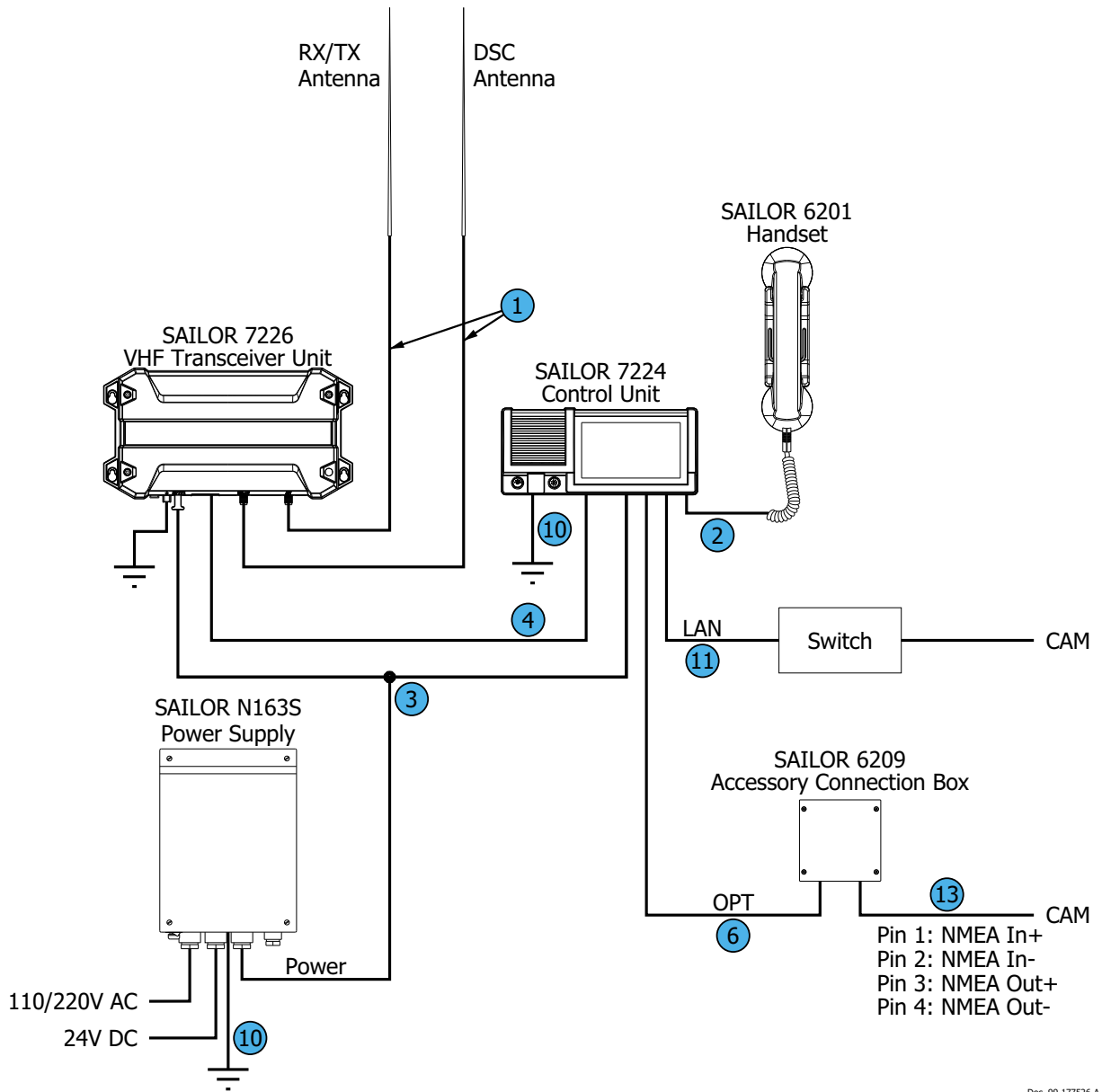
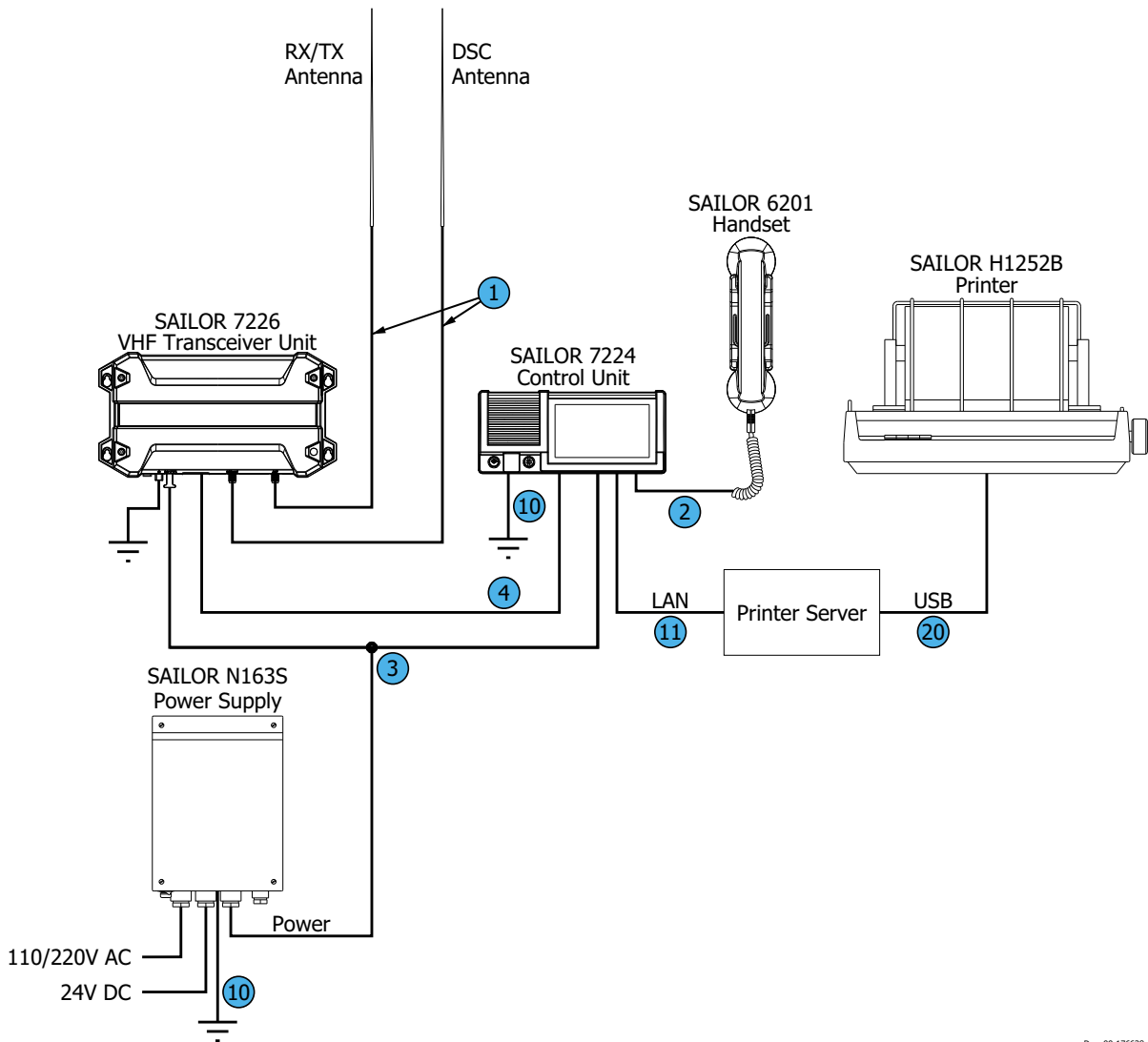

Figure C-14: System configuration: Installation of Central Alert Management (CAM)

### C.1.15 How to install a printer



Doc. 99-176638-A

Figure C-15: System configuration: Installation of a printer



## C.2 Cable requirements

The following cable information relates to the cable numbers in the system configuration drawings on the previous pages.

Cable	Part number	Description	Specification	Remarks
1		Antenna cable	RG214 or better	
2		Handset cable	1 m, spiraled	Part of handset
3	37-130130	Power cable	2.5 m power cable, 4 pin	Included in the 407222A
4	(407224A-980)	LAN Ethernet cable	CAT6, max length 50 m, Shielded	A 5 m cable for connecting the Control Unit to the Transceiver Unit is available, part number 407224A-980.
5	406209-940	5 m cable for bulk mount	10-pole LTW cable with screen	
6	406209-941	5 m cable for SAILOR 6207/09 Connection Box	10-pole LTW cable with screen	Included in Connection box 6207 & 6209
7		NMEA input	2 wire screened cable for NMEA (GNSS connection)	
8	406208-941	5 m cable for SAILOR 6208 Connection Box	12-pole LTW cable with screen	Included in Connection Box 6208
9		External speaker interface	2-pole screened cable for speaker	
10		Ship Ground connection.	Length 0.3 m, Wire size min. 1.5 mm <sup>2</sup>	
11		LAN Ethernet cable	CAT6	Shielded
12	406204-940	5 m cable for SAILOR 6204 Control Speaker Microphone	12-pole LTW cable for CAN with screen	Extension cable with 12-pole LTW plugs in both ends. Included in 406204 CSM
13		NMEA interface	4 wire screened cable for NMEA (CAM interface)	
14				Not in use

Table C-1: Cable overview

Cable	Part number	Description	Specification	Remarks
15		Cable for SAILOR 6204 Control Speaker Microphone	2.5 m spiraled	Part of handset
16		Cable for CAN	Screened with twisted pairs, length and size. See cable description for Cable 16 page C- 23.	Extension cable for CAN bus, see also under cable description for Cable 16 page C-23.
17	406204-940	Same as cable 12		
18				Not in use
19				Not in use
20		USB 2.0 cable		Connection of printer to printer server.

Table C-1: Cable overview (Continued)

### Cable 1

Cable type: Coax cable RG 214 or better.

### Cable 2 (Handset, cable included)

SAILOR 7222 VHF DSC ACC connector LTW 10-pin, circular male		Signal designation	Signal description
Pin 1		NC	
Pin 2		NC	
Pin 3		NC	
Pin 4		NC	
Pin 5		MIC+	Microphone signal
Pin 6		Earpiece	Earpiece signal
Pin 7		Hook_PTT	Hook/PTT signal
Pin 8		Battery+ (10.8-15.6 VDC)	Battery supply when radio is on
Pin 9		Internal GND = -Battery	Equipment ground
Pin 10		Internal GND = -Battery	Equipment ground

Table C-2: Cable specifications for cable 2

### Cable 3 (Power cable, delivered with the Control Unit)

Pin	Pin function	Wire color
1	DC+ (24 V DC +30% -10%)	Red
2	DC- (0 V DC)	Black
3	ON/OFF	White
4	NC	Blue
Cable screen		-

Table C-3: Pin allocation, power to Control Unit

### Cable 4 (LAN Ethernet cable)

Shielded Ethernet CAT6 cable, max length 50 m

### Cable 5

Connection cable for bulkhead mount, 5 m.

Part number: 406209-940

Same pin configuration as cable 6.

### Cable 6 (Cable for SAILOR 6207 Connection Box)

Cable type: 10-wire screened cable.

Part number: 406209-941

The cable screen must not touch any metal part of the connection box due to galvanic separation.

SAILOR 7222 ACC connector LTW 10-pin, circular male	Signal designation	Cable pin 406209-941 (5 m)	SAILOR 6207 Connection Box In from VHF	SAILOR 6207 Connection Box Ext. connections	Signal description
Pin 1	NMEA In+	Brown	1-1	2(3)-1	Impedance: 600 Ohm. Max. 2 mA at min. level of 2 V (61162-1)
Pin 2	NMEA In-	Blue	1-2	2(3)-2	
Pin 3	NMEA In-	White	1-3	2(3)-3	Impedance: 600 Ohm. Max. 2 mA at min. level of 2 V
Pin 4	NMEA In+	Green	1-4	2(3)-4	
Pin 5	MIC+	Yellow	1-5	2(3)-5	Microphone signal
Pin 6	Earpiece	Grey	1-6	2(3)-6	Earpiece signal

Table C-4: Cable specifications for cable 5

<b>SAILOR 7222 ACC connector LTW 10-pin, circular male</b>	<b>Signal designation</b>	<b>Cable pin 406209-941 (5 m)</b>	<b>SAILOR 6207 Connection Box In from VHF</b>	<b>SAILOR 6207 Connection Box Ext. connections</b>	<b>Signal description</b>
Pin 7	Hook_PTT	Pink	1-7	2(3)-7	Hook/PTT signal
Pin 8	Battery+ (10.8- 15.6 VDC)	Red	1-8	2(3)-8	Battery supply when radio is on
Pin 9	Internal GND= -Battery	Black	1-9	2(3)-9	Equipment ground
Pin 10	Internal GND= -Battery	Orange - SCREEN (Drain)	1-10	2(3)-10	Equipment ground
	Cable screen		1-11	2(3)-11	Cable screen must not touch any metal part of the connection box.
			1-12	2(3)-12	Not in use.

Table C-4: Cable specifications for cable 5

## Cable 7

2-wire screened cable for NMEA (GNSS connection).

## Cable 8 (AUX)

Part number: 406208-941

<b>SAILOR 7222 AUX connector LTW 12- pin, circular male</b>	<b>Signal desig- nation</b>	<b>Cable pin 406208- 941 (5 m)</b>	<b>SAILOR 6208 Conn. Box In from VHF</b>	<b>SAILOR 6208 Conn. Box Out of box</b>	<b>SAILOR 6208 Conn. Box Out of box</b>	<b>Signal description</b>	<b>Ships cable 6 twisted pairs overall screen</b>
Pin 1	Shield/ GND	Brown	J1-1	J2-1	J3-1	Equipment ground	paired with no. 8
Pin 2	Lo Power	Blue	J1-2	J2-2	J3-2	Low power forced control. Active when connected to ground	paired with no. 3

Table C-5: Cable specifications for cable 8 (AUX)

SAILOR 7222 AUX connector LTW 12-pin, circular male	Signal designation	Cable pin 406208-941 (5 m)	SAILOR 6208 Conn. Box In from VHF	SAILOR 6208 Conn. Box Out of box	SAILOR 6208 Conn. Box Out of box	Signal description	Ships cable 6 twisted pairs overall screen
Pin 3	NMEA+ In	White	J1-3	J2-3	J3-3	Impedance: 600 Ohm. Max. 2 mA at min. level of 2 V	paired with no. 2
Pin 4	NMEA- In	Green	J1-4	J2-4	J3-4		paired with no. 7
Pin 5	AUX	Yellow	J1-5	J2-5	J3-5	Open Collector output. Closing on event predefined through service programming <sup>a</sup>	paired with no. 6
Pin 6	DSC Call	Grey	J1-6	J2-6	J3-6	Open Collector output. Closing on incoming DSC call (see footnote)	paired with no. 5
Pin 7	DSC Alarm	Pink	J1-7	J2-7	J3-7	Open Collector output. Closing on incoming DSC alert (see footnote)	paired with no. 4
Pin 8	Battery-	Red	J1-8	J2-8	J3-8	Battery GND	paired with no. 1
Pin 9	Ext. Speaker+	Black	J1-9	J2-9	J3-9	VHF radio external speaker output, nom. 6 W into 8 Ohm	paired with no. 10
Pin 10	Ext. Speaker+	Orange	J1-10	J2-10	J3-10		paired with no. 9
Pin 11	VDR+	Purple	J1-11	J2-11	J3-11	Mixed RX/TX audio output for recording. Galvanically isolated, balanced signal, 0 dBm into 600 Ohm	paired with no. 12
Pin 12	VDR-	Light green	J1-12	J2-12	J3-12		paired with no. 11

Table C-5: Cable specifications for cable 8 (AUX) (Continued)

a. 24 VDC, max. 100 mA

## CAN cable (Cable 8 - CTRL)

Part number: 406208-941

SAILOR 7222 CTRL connector LTW 12-pin, circular male	Signal designation	Cable pin 406208-941 (5 m)	SAILOR 6208 Conn. Box In from VHF	SAILOR 6208 Conn. Box Out of box	SAILOR 6208 Conn. Box Out of box	Signal description	Ships cable 6 twisted pairs overall screen
Pin 1	Shield/GND	Brown	J1-1	J2-1	J3-1	Equipment ground	paired with no. 8
Pin 2	Battery-	Blue	J1-2	J2-2	J3-2	Battery -	paired with no. 3
Pin 3	Battery+	White	J1-3	J2-3	J3-3	10.8-15.6 VDC from VHF radio	paired with no. 2
Pin 4	Battery+	Green	J1-4	J2-4	J3-4	10.8-15.6 VDC from VHF radio	paired with no. 7
Pin 5	CAN_H	Yellow	J1-5	J2-5	J3-5	CAN bus data	paired with no. 6
Pin 6	CAN_L	Grey	J1-6	J2-6	J3-6		paired with no. 5
Pin 7	Battery-	Pink	J1-7	J2-7	J3-7	Battery -	paired with no. 4
Pin 8	ON/OFF from CSM	Red	J1-8	J2-8	J3-8	ON/OFF signal from Control Speaker Microphone	paired with no. 1
Pin 9	RX+	Black	J1-9	J2-9	J3-9	RX telephony (out)	paired with no. 10
Pin 10	RX-	Orange	J1-10	J2-10	J3-10		paired with no. 9
Pin 11	TX+	Purple	J1-11	J2-11	J3-11	TX telephony (in)	paired with no. 12
Pin 12	TX-	Light green	J1-12	J2-12	J3-12		paired with no. 11

Table C-6: Cable specifications for cable 8 (CTRL)

**Cable 9**

2-pole screened cable for speaker.

**Cable 10**

Ship ground connection, 0.3 m, Wire size min. 1.5 mm<sup>2</sup>.

**Cable 11**

LAN connection.

Ethernet cable with screen and RJ45 shielded plugs, min. cat. 6.

Pin number	Pin function	Wire color
1	Tx+	white/orange
2	Tx-	orange
3	Rx+	white/green
4	Not connected	blue
5	Not connected	white/blue
6	Rx-	green
7	Not connected	white/brown
8	Not connected	brown

Table C-7: Pin allocation, LAN connector

**Cable 12**

5 m cable for SAILOR 6204 Control Speaker Microphone. See *CAN cable (Cable 8 - CTRL)* on page C-22 for pinout.

**Cable 13**

4 wire screened cable for NMEA (CAM interface).

**Cable 15**

2.5 m spiraled cable for SAILOR 6204 Control Speaker Microphone

**Cable 16**

The CAN bus cable must be of a paired and twisted type designed for the purpose. The CAN bus cable can handle signals up to 100 m away from the VHF radio to further Control Speaker Microphones (CSM).

Only 1 CSM can be connected to the VHF radio with a CAN bus cable of max 100 m if the cable dimension is 0.5mm<sup>2</sup> of each cord. Other combinations with more CSMs must be calculated seriously before installing the cable. If more CSMs are connected, the CAN cable

of 0.5mm<sup>2</sup> can handle the signals up to max. 100 m. The only restriction is the power supply for the connected CSMs.

The voltage drop along the cable increases with the length of the cable. Separate supply cables can be installed in parallel with the CAN cable to reduce voltage drop in long cables. The maximum allowed voltage drop from VHF to CSM is 2 VDC. It means 1 VDC forward and 1 VDC return.

Max current consumption for each CSM is 0.5A.

**Formula to calculate DC resistance in a wire:**

$$R = 0,017 \times L/a$$

L = length of wire one way, in meter

a = cross section of the wire in mm<sup>2</sup>

Contact your local dealer for further information for correct installation.

### Cable 17: CAN cable for bulkhead installation.

Same cable as cable 12, but the plug is removed and the wires are connected to the connection box.

Same pin configuration as cable 8. See *Cable specifications for cable 8 (CTRL)* on page C-22.

### Cable 20

Standard USB 2.0 cable to connect printer server and printer.



## A

- API Application Programming Interface
- ATIS Automatic Transmission Identification System

## B

- BAM Bridge Alert Management (BAM) is a concept, defined by the IMO, for the management, handling and harmonized presentation of alerts on the bridge.

## C

- CAM Central Alert Management ,
- CAN Controller-Area Network
- CSM Control Speaker Microphone
- CTRL Control
- CU Control Unit

## D

- DHCP Dynamic Host Configuration Protocol
- DSC Digital Selective Calling

## G

- GNSS Global Navigation Satellite System
- GUI Graphical User Interface

## L

- LAN Local Area Network
- LWE Light Weight Ethernet

## N

- NMEA National Marine Electronics Association ,

## R

- RAINWAT Regional Arrangement Concerning the Radiotelephone Service on Inland Waterways.

## T

- TFT display Thin Film Transistor display
- TMA ThraneLINK Management Application. An application used to monitor and control products connected in a ThraneLINK network.
- TU Transceiver Unit

## U

UTC Universal Time, Coordinated

## V

VDR Voyage Data Recorder

VHF Very High Frequency

VSWR Voltage Standing Wave Ratio

## Z

Zeroconf Zeroconf is a set of technologies that automatically creates a usable computer network based on the Internet Protocol Suite (TCP/IP) when computers or network peripherals are interconnected.

## A

- ACC connector 2-11
- activate
  - scan resume 4-4
- adjust
  - speaker volume 3-1
- ANT connector 2-20
- ATIS code 4-4
  - type in 4-4
- auto-acknowledgment setup 4-9
- automatic channel switch 4-9
- AUX OC 4-5

## B

- backlight 1-1
- Bridge Alert Management
  - setup 4-10
- browse channels 3-1

## C

- cable
  - CAN C-22
  - cable for VHF antenna 2-20
  - cable overview C-17
  - cable requirements C-17
- call channel 4-5
  - programming 4-5
- CAN cable C-22
- CAN interface setup 4-5
- change MMSI number 3-2
- change password for configuration 4-12
- channel
  - select 3-1
  - working 3-1
- channel properties 4-6
- channel selector knob 1-2, 3-1
- channel setup 4-5
- channel table 4-5
- color theme for display 4-13
- communication inactivity 4-9
- compass safe distance 2-3
- configuration
  - load from file to Control Unit 4-12
  - save from Control Unit to a file 4-12
  - system example 1-5
- configuration of the VHF radio 4-2

- configurations
  - examples C-1
  - systems C-1
- connect Control Unit and Transceiver Unit 2-28
- connect to other units C-1
- connector
  - ACC 2-11
  - ANT 2-20
  - CTRL 2-12, 2-14
    - ground, Control Unit 2-17
    - ground, Transceiver Unit 2-18
  - OPT 2-13
  - VHF antenna 2-20
- contact 5-1
- controls, front plate 1-2
- CTRL connector 2-12, 2-14

## D

- default reset 4-12
- delivery, items included 2-1
- display 1-2
  - color change 4-13
- distress inactivity 4-9
- DSC
  - loopback test 5-4
- DSC alarms, sound
  - non distress 4-9
- DSC groups 4-8
- DSC self test 5-4

## E

- enter MMSI number 3-2
- error messages A-6

## F

- factory defaults 4-12
- flush mount 2-6
- frequency range, VHF A-1
- front plate, controls 1-2
- fuse
  - VHF radio 5-5

## G

- GNSS input 2-23
- GNSS settings 4-8

- ground connection
  - Control Unit 2-17
  - Transceiver Unit 2-18
- ground stud 2-17
- grounding 2-17

## H

- hand microphone
  - installing 2-9
- handset volume 4-5
- hang time 4-4
- hardware tracking number 4-14

## I

- inactivity timeout 4-12
- input
  - GNSS 2-23
  - handset 2-23
- installation
  - desktop 2-3
  - flush mount 2-6
  - mounting bracket 2-4
  - overhead 2-4
- IP rating A-1

## K

- keys on front plate 1-2
- knob
  - channel selector 1-2
  - volume and squelch 1-2

## L

- LAN ports on Control Unit 4-11
- LAN setup 4-11
- load configuration 4-12
- louder, volume 3-1
- LWE talker ID 4-10

## M

- medical transport option
  - for Urgency DSC calls 4-9
- MMSI
  - number, changing 3-2
- MMSI, enter in the radio 3-2, 4-8
- monitor power supply 4-10
- mounting 2-2
  - flush mount 2-6
  - with mounting bracket 2-4

## N

- network setup 4-11
- neutral crafts 4-9
- NMEA
  - interface 2-12
  - interface description A-5
- NMEA HS 2-11
- NMEA sentence B-1
- non-distress alarm sound 4-9
- non-distress inactivity 4-9

## O

- OPT connector 2-13

## P

- pairing Control Unit and Transceiver Unit 4-12
- password for configuration
  - change 4-12
- position Info 4-8
- power
  - fuse 5-5
  - off 3-1
  - on 3-1
- power supply
  - monitor 4-10
  - monitor (SAILOR 6081A) 4-10
- power up 3-1
- Print DSC messages 4-9
- printer
  - select 4-12
- priority scan 4-4
- private channels A-1

## R

- radio settings 4-4
- reboot the VHF radio 4-13
- remote control of user interface 4-13
- replay 1-1
- reset to default 4-12
- resume time 4-4
- returning units 5-6

## S

- save configuration 4-12
- scan
  - hang time 4-4
  - priority 4-4
  - resume time 4-4
  - resume, activate 4-4
- scan hang time 4-4

- scan resume time 4-4
- select printer 4-12
- self test 5-4
  - of DSC 5-4
- semi duplex 1-1
- serial number 4-14
- Service port (LAN)
  - configuration 4-11
- SETTINGS 4-2
  - ABOUT 4-14
  - access the menu 4-2
  - CHANNELS 4-5
  - CONTROLLER 4-5
  - DSC 4-8
  - menu tree 4-3
  - NETWORK 4-11
  - NMEA 4-10
  - POWER SUPPLY 4-10
  - RADIO 4-4
  - REMOTE CONTROL 4-13
  - SYSTEM 4-12
- setup
  - system 4-12
- ship ground 2-17
- simplex 1-1
- softer, volume 3-1
- software update 4-12, 5-1
- software version 4-14
- speaker volume 3-1, 4-5
- specifications A-1
- squelch control 1-2
- squelch knob 1-2
- support 5-1
- system configuration
  - example 1-5
- system configurations C-1
- system settings 4-12
- system setup 4-12

## T

- technical data A-1
- temperature
  - operational A-1, A-3
  - storage A-1, A-3
- theme
  - color, change 4-13
- ThraneLINK Management Application 5-2
- timeout
  - distress 4-9
  - non distress 4-9
  - VHF and other non distress 4-9
- timeout in user interface 4-12

- TMA 5-2
  - installing 5-2
- Transceiver Unit
  - connect to Control Unit 2-28
- transmission group B-1

## U

- update software 4-12, 5-1
- user interface
  - remote control 4-13

## V

- VHF
  - antenna cable 2-20
  - antenna connector 2-20
  - frequency range A-1
- volume
  - louder 3-1
  - softer 3-1
  - speaker 3-1
- volume knob 1-2

## W

- warnings A-6
- warranty 5-6
- water ingress A-1
- weight A-3
- working channel 3-1

