

VMH SERIES

VMH 14

USER MANUAL
rev. AA



EN

DE

IT

FR

ES



CONTENT

| | |
|----------------------------|-----------|
| Introduction | 3 |
| Packaging Content | 3 |
| The All-in-one Gauge | 3 |
| Contactless Configuration | 3 |
| Safety information | 4 |
| Safety during Installation | 4 |
| Safety After installation | 5 |
| Electrical Connections | 5 |
| Installation | 6 |
| Before the Assembly | 6 |
| Installation with Spinlock | 7 |
| Connection | 8 |
| Device Pinout | 8 |
| EasyLink Connection | 8 |
| Display layout | 10 |
| Display Sections | 10 |
| Alarm Display | 10 |
| Configuration | 11 |
| VMH 14 Configurator App | 11 |
| VMH 14 Configuration | 12 |
| Supported Configurations | 14 |
| Alarm Settings | 14 |
| Technical Data | 15 |
| Datasheet | 15 |
| Technical Drawings | 16 |
| Accessories | 17 |

INTRODUCTION

PACKAGING CONTENT



1x VMH 14
B001099



**1x 52 mm Rubber
sealing gasket**
A2C53194838



**1x 52 mm Mounting
Spinlock**
A2C52059471



1x Veratron card
B000101



1x Safety manual
B000100

THE ALL-IN-ONE GAUGE

The VMH device can easily be configured to be the instrument you need - thanks to its sun-readable display embedded into a standard 52 mm instrument housing with the elegant VMH-series look.

The EasyLink-Interface allows the device to display a variety of different datatypes, received from any VMH- or OceanLink master device.

CONTACTLESS CONFIGURATION

Thanks to the contactless configuration you can setup your all-in-one instrument with your smartphone!

Launch the companion app and define your settings through the user-friendly interface, then

The simple but effective graphic design presents the data in a clear and intuitive form. In addition, the round bar graph with the customizable range and the alarm displays helps you to visually better understand your data.

simply hold your mobile device in proximity of the VMH 14 device to transfer the configuration.

Thanks to the embedded passive antenna the configuration can be done powerless!

SAFETY INFORMATION

WARNING

- No smoking! No open fire or heat sources!
- The product was developed, manufactured and inspected according to the basic safety requirements of EC Guidelines and state-of-the-art technology.
- The instrument is designed for use in grounded vehicles and machines as well as in pleasure boats, including non-classified commercial shipping.
- Use our product only as intended. Use of the product for reasons other than its intended use may lead to personal injury, property damage or environmental damage. Before installation, check the vehicle documentation for vehicle type and any possible special features!
- Use the assembly plan to learn the location of the fuel/hydraulic/compressed air and electrical lines!
- Note possible modifications to the vehicle, which must be considered during installation!
- To prevent personal injury, property damage or environmental damage, basic knowledge of motor vehicle/shipbuilding electronics and mechanics is required.
- Make sure that the engine cannot start unintentionally during installation!
- Modifications or manipulations to veratron products can affect safety. Consequently, you may not modify or manipulate the product!
- When removing/installing seats, covers, etc., ensure that lines are not damaged and plug-in connections are not loosened!
- Note all data from other installed instruments with volatile electronic memories.

SAFETY DURING INSTALLATION

- During installation, ensure that the product's components do not affect or limit vehicle functions. Avoid damaging these components!
- Only install undamaged parts in a vehicle!
- During installation, ensure that the product does not impair the field of vision and that it cannot impact the driver's or passenger's head!
- A specialized technician should install the product. If you install the product yourself, wear appropriate work clothing. Do not wear loose clothing, as it may get caught in moving parts. Protect long hair with a hair net.
- When working on the on-board electronics, do not wear metallic or conductive jewelry such as necklaces, bracelets, rings, etc.
- If work on a running engine is required, exercise extreme caution. Wear only appropriate work clothing as you are at risk of personal injury, resulting from being crushed or burned.
- Before beginning, disconnect the negative terminal on the battery, otherwise you risk a short circuit. If the vehicle is supplied by auxiliary batteries, you must also disconnect the negative terminals on these batteries! Short circuits can cause fires, battery explosions and damages to other electronic systems. Please note that when you disconnect the battery, all volatile electronic memories lose their input values and must be reprogrammed.
- If working on gasoline boat motors, let the motor compartment fan run before beginning work.
- Pay attention to how lines and cable harnesses are laid so that you do not drill or saw through them!
- Do not install the product in the mechanical and electrical airbag area!
- Do not drill holes or ports in load-bearing or stabilizing stays or tie bars!
- When working underneath the vehicle, secure it according to the specifications from the vehicle manufacturer.
- Note the necessary clearance behind the drill hole or port at the installation location. Required mounting depth: 65 mm.

- Drill small ports; enlarge and complete them, if necessary, using taper milling tools, saber saws, keyhole saws or files. Deburr edges. Follow the safety instructions of the tool manufacturer.
- Use only insulated tools if work is necessary on live parts.
- Use only the multimeter or diode test lamps provided, to measure voltages and currents in the vehicle/machine or boat. Use of conventional test lamps can cause damage to control units or other electronic systems.
- The electrical indicator outputs and cables connected to them must be protected from direct contact and damage. The cables in use must have enough insulation and electric strength and the contact points must be safe from touch.
- Use appropriate measures to also protect the electrically conductive parts on the connected consumer from direct contact. Laying metallic, uninsulated cables and contacts is prohibited.

SAFETY AFTER INSTALLATION

- Connect the ground cable tightly to the negative terminal of the battery.
- Reenter/reprogram the volatile electronic memory values.
- Check all functions.
- Use only clean water to clean the components. Note the Ingress Protection (IP) ratings (IEC 60529).

ELECTRICAL CONNECTIONS

- Note cable cross-sectional area!
- Reducing the cable cross-sectional area leads to higher current density, which can cause the cable cross-sectional area in question to heat up!
- When installing electrical cables, use the provided cable ducts and harnesses; however, do not run cables parallel to ignition cables or to cables that lead to large electricity consumers.
- Fasten cables with cable ties or adhesive tape. Do not run cables over moving parts. Do not attach cables to the steering column!
- Ensure that cables are not subject to tensile, compressive or shearing forces.
- If cables are run through drill holes, protect them using rubber sleeves or the like.
- Use only one cable stripper to strip the cable. Adjust the stripper so that stranded wires are not damaged or separated.
- Use only a soft soldering process or commercially available crimp connector to solder new cable connections!
- Make crimp connections with cable crimping pliers only. Follow the safety instructions of the tool manufacturer.
- Insulate exposed stranded wires to prevent short circuits.
- Caution: Risk of short circuit if junctions are faulty or cables are damaged.
- Short circuits in the vehicle network can cause fires, battery explosions and damages to other electronic systems. Consequently, all power supply cable connections must be provided with weldable connectors and be sufficiently insulated.
- Ensure ground connections are sound.
- Faulty connections can cause short circuits. Only connect cables according to the electrical wiring diagram.
- If operating the instrument on power supply units, note that the power supply unit must be stabilized and it must comply with the following standard: DIN EN 61000, Parts 6-1 to 6-4.

INSTALLATION

⚠ WARNING

Before beginning, disconnect the negative terminal on the battery, otherwise you risk a short circuit. If the vehicle is supplied by auxiliary batteries, you must also disconnect the negative terminals on these batteries! Short circuits can cause fires, battery explosions and damages to other electronic systems. Please note that when you disconnect the battery, all volatile electronic memories lose their input values and must be reprogrammed.

BEFORE THE ASSEMBLY

1. Before beginning, turn off the ignition and remove the ignition key. If necessary, remove the main circuit switch.

Disconnect the negative terminal on the battery. Make sure the battery cannot unintentionally restart.

Refer to the safety instructions of this document.

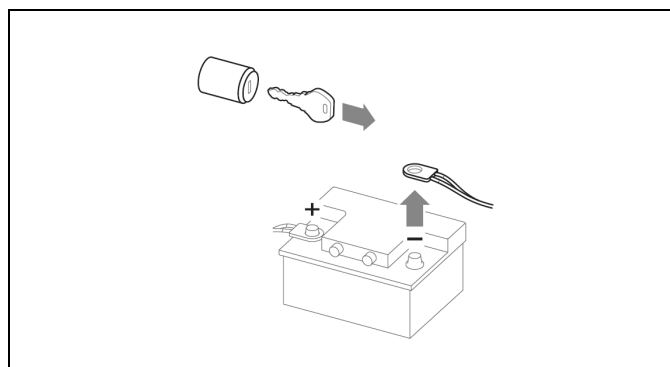

2. Place the device at least 300 mm away from any magnetic compass.

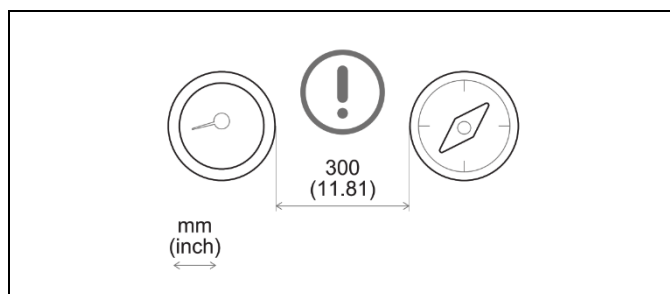

3. Consider that the device must be connected to an VMH master device and/or other VMH 14 gauges (maximum 16 gauges in a daisy chain per master).

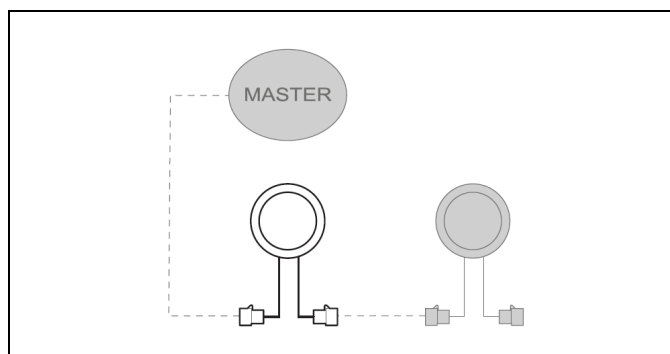

INSTALLATION WITH SPINLOCK

The panel width may be within a range of 1 to 12 mm. The drill hole must have a diameter of 52 mm [A].

WARNING

- Do not drill holes or ports in load-bearing or stabilizing stays or tie bars!
- Note the necessary clearance behind the drill hole or port at the installation location. Required mounting depth: 40 mm.
- Drill small ports; enlarge and complete them, if necessary, using taper milling tools, saber saws, keyhole saws or files. Deburr edges. Follow the safety instructions of the tool manufacturer.

1. Create a circular hole in the panel considering the device dimensions. [A]
2. Remove the spinlock and insert the device from the front. [B]
3. Adjust the spinlock as shown in picture [C] according to the panel thickness.
4. Carefully screw in the spinlock by hand at least two turns.
5. Insert the connector.

A

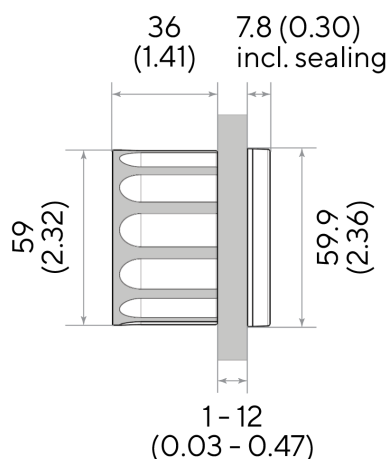

B

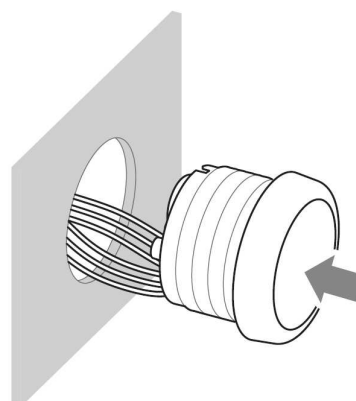

C

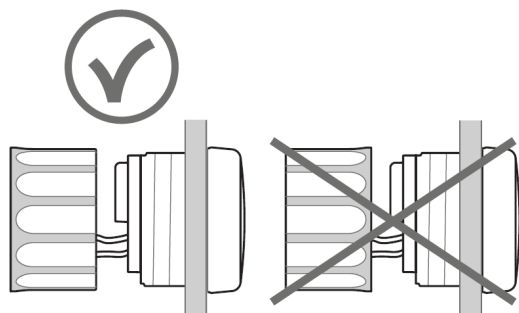

CONNECTION

DEVICE PINOUT

The VMH 14 device is designed with two AMP SuperSeal 1.5 connectors on the backside – one male and one female – to allow the daisy-chain connection of up to 16 instruments in series to the master.

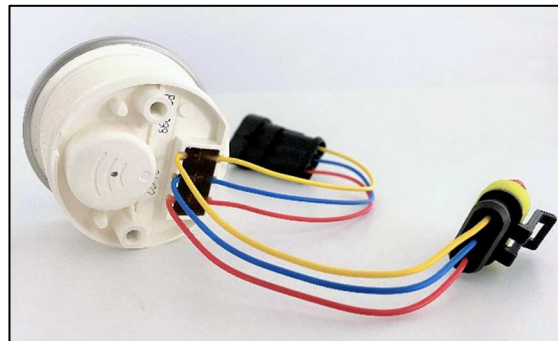

| Wire color | Description |
|------------|---------------|
| Red | + 12V power |
| Blue | Ground |
| Yellow | EasyLink data |

EASYLINK CONNECTION

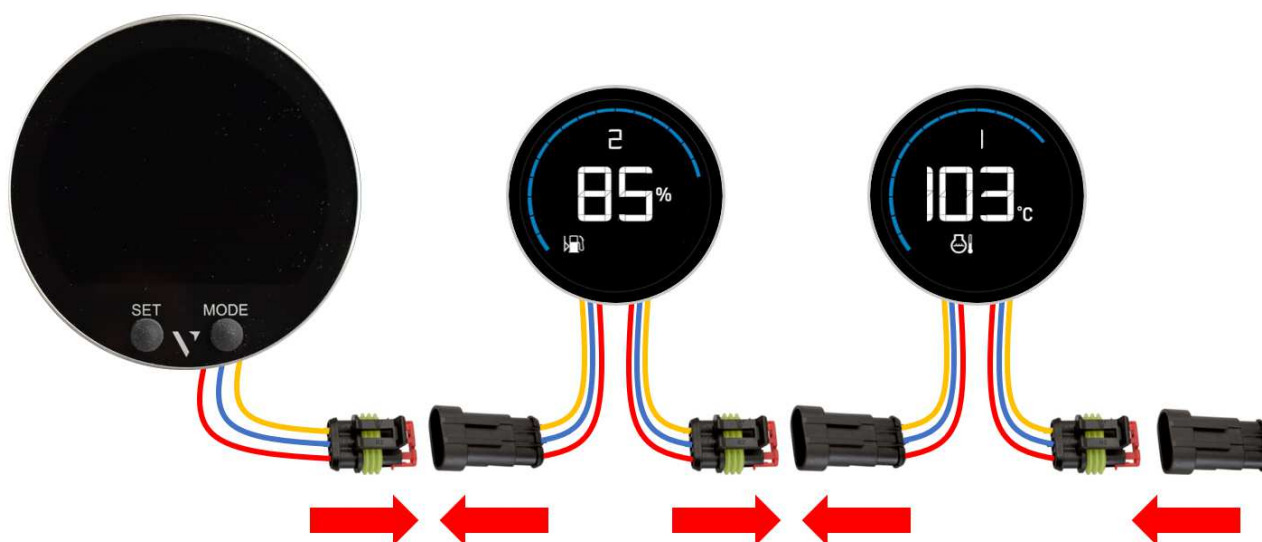

EasyLink connection with VMH 35 master and two VMH 14 satellites

Once the panel installation is complete it is possible to connect the VMH 14 to the EasyLink interface.

The device can be directly connected to the EasyLink master (like the VMH 35 display), or in series to another VMH 14 satellite thanks to the daisy-chain architecture.

NOTE: One master must always be present in the system to distribute the data to the satellites.

Make sure the contacts have been locked audibly into place so to preserve the water tightness.

In case the length of the cable is not enough to reach the next device, it is possible to extend the total length by using the accessory EasyLink extension cable A2C59500139.

Please note that EasyLink does not allow daisy chains longer than 20 meters and with maximum 16 satellite devices.

It is recommended to connect the blind plug (provided with the master instrument) after the last satellite instrument to avoid water intrusion through the unused connector.



DISPLAY LAYOUT

DISPLAY SECTIONS

A: Round Bar Graph

The bar graph helps to interpret the displayed vessel information quicker and more intuitive. The minimum and maximum values of the bar graph range are customizable via the VMH14 App.

(Refer to the section Configurations to learn more about the process of customizing and the limitations of the bar graph ranges.)

B: Numeric Value

The big number in the middle represent the measured value.

C: Unit

The unit of measurement is displayed right next to the numeric measurement value.

D: Instance

For some data types it's possible that there are several different values available on the EasyLink bus. The number in "area D" represents the instance number of the value, currently displayed. This means, depending on the data type, the engine number/ tank number/etc..

E: Data Type Symbol

On the bottom of the display there is a symbol representing the currently selected data type. Refer to the section Configuration to see all displayable values and their according symbols.

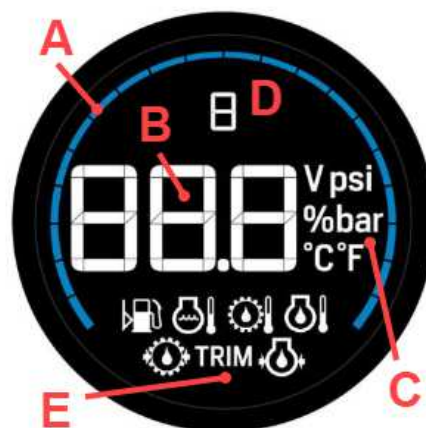

ALARM DISPLAY

The display can indicate that the received value has exceeded or fell below a certain threshold. If this is the case, the bar graph and the numeric value will start to blink with a frequency of 1Hz.

More information about the alarm settings and how to configure them can be found in the section "Configuration".

CONFIGURATION

VMH 14 CONFIGURATOR APP

To configure the VMH 14, some parameters must be calibrated, like which value to display, the range of the bar graph and the alarms such as their thresholds.

This is possible through the smartphone App “VMH 14”, which can be downloaded free of charge from the stores of both Android and iOS devices.

A simple and detailed explanation of the configuration process is also available as in-app instructions.

Thanks to the passive embedded NFC receiver, the VMH 14 can be configured, as described below, without the need of a power supply.



VMH 14 CONFIGURATOR



The setup of the VMH 14 device is an intuitive three-step process. Please remember that you must READ from the device before being able to modify and download the configuration to the instrument.

1. READ



2. CONFIGURE



3. WRITE



VMH 14 CONFIGURATION

1. READ THE VMH 14 CONFIGURATION

Launch the “VMH 14” App and read the current configuration of the device by “tapping” the smartphone onto the NFC symbol on the devices rear side.

The READ operation is mandatory before the WRITE operation is allowed.

After the readout, the App will be set with the current configuration.

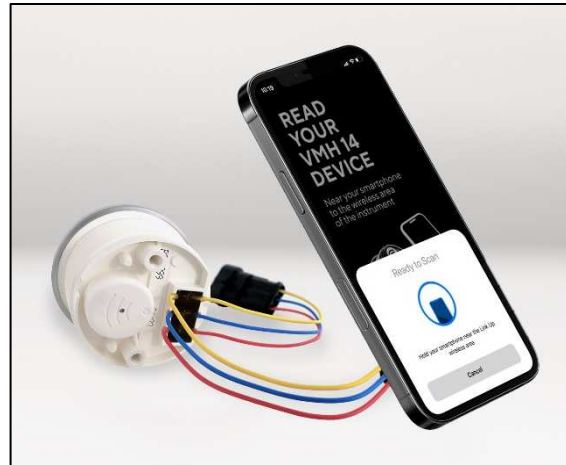

NOTE: The antenna position on the smartphone depends on the model. Please refer to the smartphone manufacturer manual.

2. SELECT GAUGE TYPE

Tap the “Data to display” item in the “Display Settings” section to choose the data you want to display on the VMH 14.

Note: See the complete list of supported gauge types in the “Supported Configurations” table of this document.

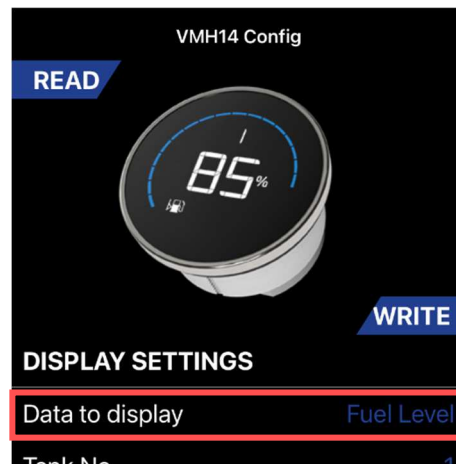

3. SET UNITS AND INSTANCE

Define the unit for the displayed value if more than one is available (see “Supported Configurations” table).

Set the instance for the displayed value (e.g. Engine No. or Tank No.) so that the VMH 14 will show your data on the display.

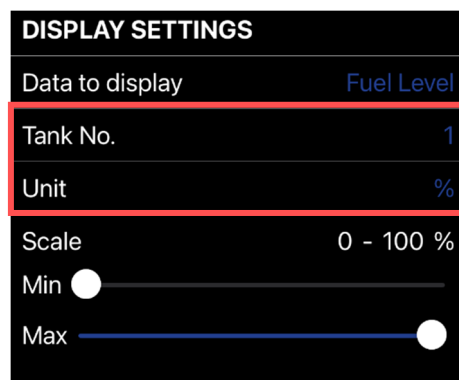

4. BARGRAPH SETTINGS

It's possible to customize the range of values, which the bar graph should be able to reach. In order to do so, just move the levers into the desired position.

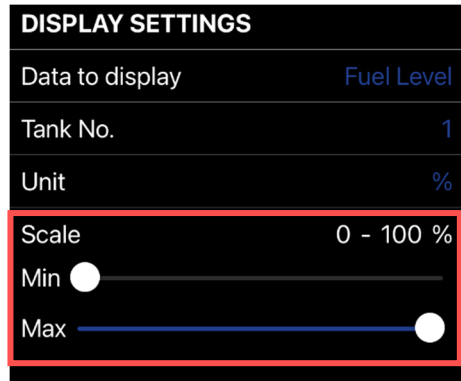

5. CONFIGURE THE ALARM

The alarm can be activated or deactivated by using the switches on the right side of the according alarm description.

Once active, it is possible to set a threshold for it in the dedicated field. The threshold unit is the same unit as defined in step 3.

Note: the alarm threshold direction (active above or active below) is statically defined (see table "Alarm Settings").

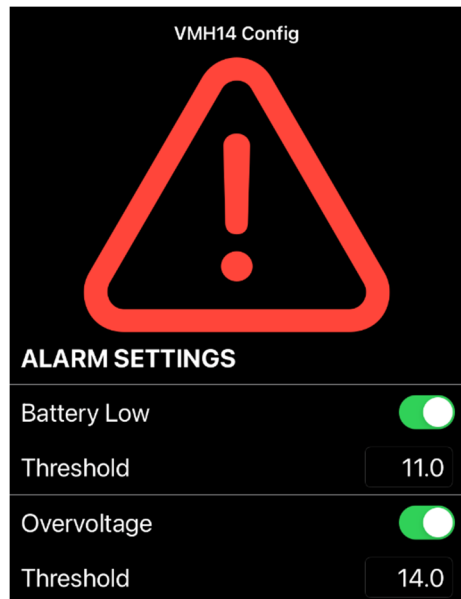





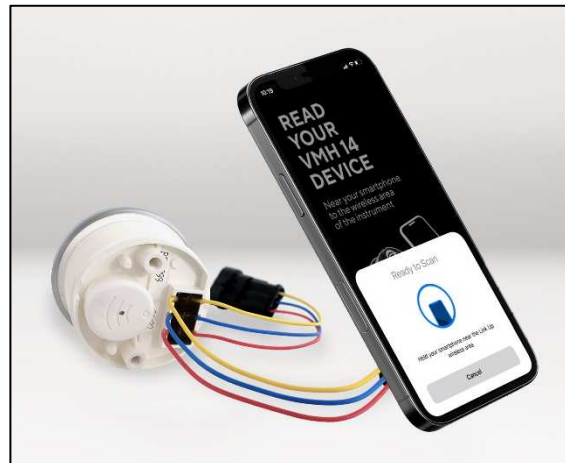

6. UPLOAD THE CONFIGURATION TO THE VMH 14

Once the configuration is completed, you can upload it to the VMH 14.

Press the "WRITE" button on the top/right of the App screen and near the smartphone again to the dedicated NFC area of the VMH device.



SUPPORTED CONFIGURATIONS

| Gauge Type | Symbol | Unit | Bar Graph Range |
|---|---|------------|---|
| Fuel Level <i>(Set as factory default)</i> |  | % | 0 - 100 % Default: 0 - 100 % |
| Trim | TRIM | % | 0 - 100 % Default: 0 - 100 % |
| Coolant Temperature |  | °C °F | 0 - 200 °C Default: 40 - 120 °C |
| Engine Oil Pressure |  | bar PSI | 0 - 30 bar Default: 0 - 10 bar |
| Engine Oil Temperature |  | °C °F | 0 - 200 °C Default: 0 - 150 °C |
| Gear Oil Pressure |  | bar PSI | 0 - 30 bar Default: 0 - 25 bar |
| Gear Oil Temperature |  | °C °F | 0 - 200 °C Default: 0 - 150 °C |
| Voltmeter | - | V | 0 - 30 V Default: 11 - 14 V |

* The supported configurations may be updated at any time. Please make sure to always use the latest App version.

ALARM SETTINGS

| Gauge Type | Alarm Description | Alarm triggered... | Possible Threshold Values |
|------------------------|---------------------------|--------------------|---------------------------|
| Fuel Level | Low Fuel Level | below threshold | 0 - 100 % |
| Coolant Temperature | Engine Overtemperature | above threshold | 0 - 200 °C |
| Engine Oil Temperature | High Oil Temperature | above threshold | 0 - 200 °C |
| Engine Oil Pressure | Low Oil Pressure | below threshold | 0 - 30 bar |
| Gear Oil Temperature | High Gear Oil Temperature | above threshold | 0 - 200 °C |
| Gear Oil Pressure | Low Gear Oil Press | below threshold | 0 - 30 bar |
| Voltmeter | Battery Low | below threshold | 0 - 30 V |
| | Overvoltage | above threshold | 0 - 30 V |
| Trim | Engine Tilt | above threshold | 0 - 100 % |

TECHNICAL DATA

DATASHEET

| | |
|--------------------------------|---|
| Nominal Voltage | 12 V (from EasyLink connection) |
| Connectivity | EasyLink, NFC |
| Configuration interface | NFC (Near Field Communication) |
| Protection class | IP X7 acc. IEC60529 |
| Display | Optically bonded IBN segment display |
| Lens | Mineral glass |
| Housing | Ø52 mm - Polycarbonate (PC), flame retardant acc. UL94-V0 |
| Required mounting depth | 40 mm |
| Bezels | Brushed stainless steel |
| Operating temperature | -20°C to +60°C |
| Storage temperature | -30°C to +80°C |
| Connector | AMP SuperSeal 1.5 P/N Male: 282105-1 P/N Female: 282087-1 |
| Mounting | Spinlock Nut - locking height 0.5 - 20 mm |
| Certifications | CE, UKCA, Reach, RoHS, UL94-V0 |

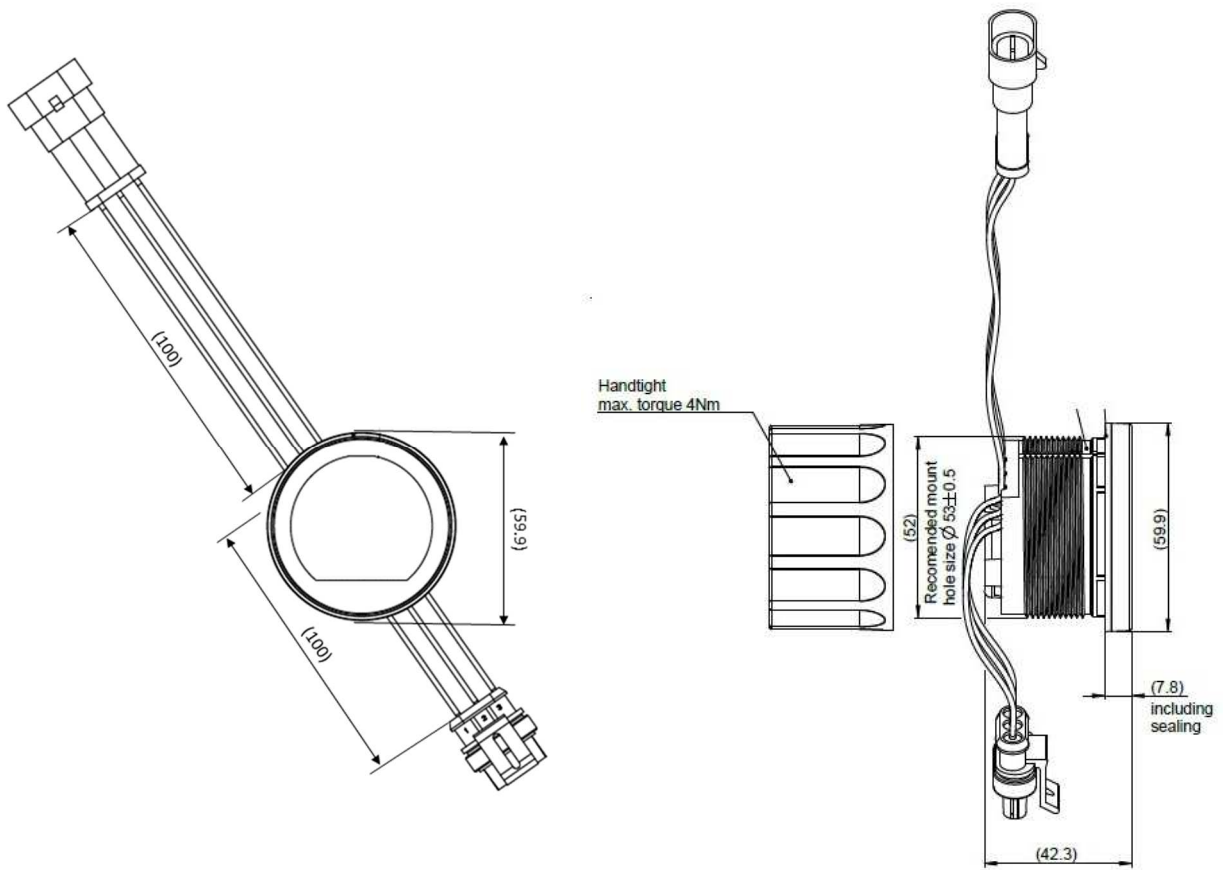

ACCESSORIES

| Accessory | Part Number |
|-----------------------------|--------------------|
| EasyLink Extension cable | A2C59500139 |
| Spinlock Nut 52 mm | A2C52059471 |
| 52 mm Rubber sealing gasket | A2C53194838 |

Visit <http://www.veratron.com> for the complete list of accessories.



veratron AG
Industriestrasse 18
9464 Rüthi,
Switzerland

T +41 71 7679 111
info@veratron.com
veratron.com

Any distribution, translation or reproduction, partial or total, of the document is strictly prohibited unless with prior authorization in writing from veratron AG, except for the following actions:

- Printing the document in its original format, totally or partially.
- Copying contents without any modifications and stating Veratron AG as copyright owner.

Veratron AG reserves the right to make modifications or improvements to the relative documentation without notice.

Requests for authorization, additional copies of this manual or technical information on the latter, must be addressed to veratron AG.