



**875-0394-10**

**V200n Vector™  
GNSS Compass**

User Guide  
Revision: A7  
March 2, 2022

## Table of Contents

---

Device Compliance, License and Patents.....	4
Terms and Definitions.....	6
Chapter 1: Introduction .....	8
Overview .....	8
Product Overview .....	9
Key Features.....	12
What’s Included in Your Kit.....	13
Using PocketMax to Communicate with the V200n.....	14
Firmware Upgrades.....	18
Chapter 2: Mounting the V200n.....	22
Overview .....	22
Mounting the V200n.....	23
Surface-mounting the V200n.....	35
Pole-mounting the V200n.....	40
Chapter 3: Connecting the V200n Compass.....	42
Overview .....	42
Ports .....	43
WebUI .....	44
Connecting the V200n to External Devices.....	57
Chapter 4: Understanding the V200n.....	58
Overview .....	58
GNSS Overview .....	59
Differential Operation.....	60
SBAS Tracking.....	61
Atlas L-band .....	62
Supplemental Sensors.....	63
Time Constants .....	66
Appendix A: Troubleshooting .....	68
Overview .....	68

Troubleshooting.....	69
Appendix B: Technical Specifications.....	72
V200n Technical Specifications.....	73
Appendix C: Common Commands and Messages .....	77
Overview .....	77
NMEA 2000 Messages .....	78
NMEA 2000 Proprietary Messages .....	87
Index.....	91
End User License Agreement .....	92
Warranty Notice.....	96

---

## Device Compliance, License and Patents

---

### Device Compliance

This device complies with part 15 of the FCC Rules. Operation is subject to the following two conditions:

1. This device may not cause harmful interference, and
2. this device must accept any interference received, including interference that may cause undesired operation.

This product complies with the essential requirements and other relevant provisions of Directive 2014/53/EU. The declaration of conformity may be consulted at [HTTPS://HEMISPHEREGNSS.COM/ABOUT-US/QUALITY-COMMITMENT](https://hemispheregnss.com/about-us/quality-commitment).

---

### Copyright Notice

Copyright Hemisphere GNSS, Inc. (2022). All rights reserved.

No part of this manual may be reproduced, transmitted, transcribed, stored in a retrieval system or translated into any language or computer language, in any form or by any means, electronic, mechanical, magnetic, optical, chemical, manual or otherwise, without the prior written permission of Hemisphere GNSS.

---

### Trademarks

Hemisphere GNSS®, the Hemisphere GNSS logo, TRACERTM, Crescent®, EclipseTM, e-Dif®, L-DifTM, PocketMaxTM, S320TM, SBX-4TM, VectorTM, Vega™, Phantom™, Cygnus™, Atlas™, aRTK, SureFix™, and Athena™ are proprietary trademarks of Hemisphere GNSS, Inc. Other trademarks are the properties of their respective owners.

---

### Patents

Hemisphere GNSS products may be covered by one or more of the following patents:

Patents			
6111549	6876920	7400956	8000381
6397147	7142956	7429952	8018376
6469663	7162348	7437230	8085196
6501346	7277792	7460942	8102325
6539303	7292185	7689354	8138970
6549091	7292186	7808428	8140223
6711501	7373231	7835832	8174437
6744404	7388539	7885745	8184050
6865465	7400294	7948769	8190337
8214111	8217833	8265826	8271194
8307535	8311696	8334804	RE41358

Australia Patents	
2002244539	2002325645
2004320401	

*Continued on next page*

## Device Compliance, License and Patents, Continued

---

**Notice to Customers**      Contact your local dealer for technical assistance. To find the authorized dealer near you:

Hemisphere GNSS, Inc  
8515 East Anderson Drive  
Scottsdale, AZ 85255 USA  
Phone: (480) 348-6380  
Fax: (480) 270-5070  
[PRECISION@HGNSS.COM](mailto:PRECISION@HGNSS.COM)  
[WWW.HGNSS.COM](http://WWW.HGNSS.COM)

---

**Technical Support**      If you need to contact Hemisphere GNSS Technical Support:

Hemisphere GNSS, Inc.  
8515 East Anderson Drive  
Scottsdale, AZ 85255 USA  
Phone: (480) 348-6380  
Fax: (480) 270-5070  
[SUPPORT.HGNSS.COM](http://SUPPORT.HGNSS.COM)

---

**Documentation Feedback**      Hemisphere GNSS is committed to the quality and continuous improvement of our products and services. We urge you to provide Hemisphere GNSS with any feedback regarding this guide by opening a support case at the following website: [HGNSS.COM](http://HGNSS.COM)

---

## Terms and Definitions

**Introduction** The following table lists the terms and definitions used in this document.

**V200n terms & definitions**

<b>Term</b>	<b>Definition</b>
Activation	Activation refers to a feature added through a one-time purchase. For features that require recurring fees, see <b>Subscription</b> .
Atlas	Atlas is a subscription-based service provided by Hemisphere GNSS.
BeiDou	BeiDou is a global navigation satellite system deployed and maintained by China.
DGPS/DGNSS	Differential GPS/GNSS refers to a receiver using Differential Corrections.
Differential Corrections	A method of improving precision of a GNSS rover. Two GNSS receivers placed in a nearby area will have similar error. A base station is placed over a known point.
Firmware	Firmware is the software loaded into the receiver that controls the functionality of the receiver and runs the GNSS engine.
Galileo	Galileo is a global navigation satellite system deployed and maintained by the European Union and European Space Agency.
GLONASS	Global Orbiting Navigation Satellite System (GLONASS) is a Global Navigation Satellite System deployed and maintained by Russia.
GNSS	Global Navigation Satellite System (GNSS) is a system that provides autonomous 3D position (latitude, longitude, and altitude) and accurate timing globally by using satellites. Current GNSS providers are GPS, GLONASS and Galileo.
GPS	Global Positioning System (GPS) is a global navigation satellite system deployed and maintained by the United States.

*Continued on next page*

## Terms and Definitions, Continued

### V200n terms & definitions, continued

Term	Definition
Heading	The vector created from the primary to secondary antenna. It points to the direction that the receiver is facing.
I/O	Input/Output
NMEA	National Marine Electronics Association (NMEA) is a marine electronics organization that sets standards for communication between marine electronics.
QZSS	Quasi-Zenith Satellite System (QZSS) is a regional satellite navigation system deployed and maintained by Japan.
RMS	Root mean square
RTK	Real-Time-Kinematic (RTK) is a real-time differential GPS method that supplies better accuracy than differential corrections.
SBAS	Satellite Based Augmentation System (SBAS) is a system that supplies differential corrections over satellite throughout a wide area or region.
SNR	Signal-to-Noise ratio
Subscription	A subscription is a feature that is enabled for a limited time. Once the end-date of the subscription has been reached, the feature will turn off until the subscription is renewed.
Vector Receiver	A Hemisphere GNSS receiver capable of providing heading.

# Chapter 1: Introduction

## Overview

---

**Introduction** This User Guide provides information to help you quickly set up your V200n GNSS Compass. You can download this manual from the Hemisphere GNSS website at [WWW.HGNSS.COM](http://WWW.HGNSS.COM).

---

## Contents

	<b>Topic</b>	<b>See Page</b>
	Product Overview	9
	Key Features	12
	What's Included in Your Kit	13
	Using PocketMax to Communicate with the V200n	14
	Firmware Upgrades	18

---



## Product Overview

---

### Product overview

The V200n Vector™ GNSS Compass is capable of tracking and using GPS, GLONASS, Galileo, BeiDou, QZSS satellites.

**Note:** When referring to the V200n Vector™ GNSS Compass, this manual uses the term V200n.

The multi-GNSS V200n offers world-wide 30 cm (RMS) accuracy via Hemisphere's Atlas GNSS global correction service.

The V200n offers an incredible combination of simple installation, small form factor, and amazing performance. The compass - measuring only 35 cm in length - mounts easily to a flat surface or pole. The stability and maintenance-free design of the V200n provides simple integration into autopilots, chart plotters, and AIS systems.

There are no mechanical parts such as gimbals or a rotating motor, so the V200n is free from routine maintenance. Heading is determined from GNSS, and there is no need to wait for settling time, gyrocompass calibration and speed corrections. Vector performance is not affected by geomagnetism, making it the perfect solution for any marine application.

The V200n is an integrated system that houses the following:

- Dual mGNSS, multipath-resistant antennas
- Power supply
- Six-axis sensor

The sensor is present to improve system performance and to provide backup heading information if a GNSS heading is not available due to signal blockage. The sensor provides a substitute heading, accurate to within 1° per minute for up to three minutes.

---

*Continued on next page*

## Product Overview, Continued

---

**Product  
overview,  
continued**

The V200n's GNSS antennas are separated by 20 cm between phase centers, resulting in a heading performance of better than 0.75° RMS (with High Accuracy Heading activated). The V200n can provide heading and positioning updates of up to 50 Hz and delivers positioning accuracy of 0.6 m 95% of the time when using differential GPS corrections from Satellite Based Augmentation Systems (SBAS) or Atlas.

If you are new to GNSS and SBAS, refer to the [Hemisphere GNSS Technical Reference Manual](#) for further information on these services and technologies before proceeding.



**Figure 1-1: V200n GNSS Compass**

---

*Continued on next page*

## Product Overview, Continued

---

### Athena RTK

Athena RTK is Hemisphere's next-generation RTK engine designed to support all available constellations and take advantage of available new signals. Athena was designed to seamlessly integrate into existing product portfolios and supports all major industry correction formats and standards.

Athena RTK can be added to the V200n as an activation.

Athena RTK has the following benefits:

- **Improved Initialization time** - Performing initializations in less than 15 seconds at better than 99.9% of the time.
- **Robustness in difficult operating environments** - Extremely high productivity under the most aggressive of geographic and landscape-oriented environments.
- **Performance on long baselines** - Industry-leading position stability for long baseline applications.

For more information about Athena RTK, see:

[HTTPS://WWW.HEMISPHEREGNSS.COM/TECHNOLOGY/#ATHENA](https://www.hemispheregnss.com/technology/#athena)

---

### Atlas L-band

Atlas L-band is Hemisphere's industry leading correction service, which can be added as a subscription. Atlas L-band has the following benefits:

- **Positioning accuracy** - Competitive positioning accuracies down to 4 cm RMS in certain applications.
- **Positioning sustainability** - Cutting edge position quality maintenance in the absence of correction signals, using Hemisphere's patented technology.
- **Scalable service levels** - Capable of providing virtually any accuracy, precision and repeatability level in the 4 cm to 50 cm range.
- **Convergence time** - Industry-leading convergence times of 10-40 minutes
- **Global Ionospheric Model** - Real-time ionospheric activity and data is sent to the receiver and allows Atlas-capable devices to adjust accordingly, providing excellent convergence performance.

For more information about Atlas L-band, see: [HTTP://HGNS.COM/ATLAS](http://hgns.com/atlas)

---

## Key Features

---

### V200n key features

Key features of the V200n include:

- L1 GPS, GLONASS, Galileo, BeiDou, QZSS
  - 30 cm RMS world-wide positioning accuracy with Atlas corrections
  - Standard 1.5° and optional 0.75° heading accuracy in small form factor
  - Excellent in-band and out-of-band interference rejection
  - Integrated gyro and tilt sensors help deliver fast start-up times and provide heading updates during temporary loss of satellites
  - Provides heading, positioning, heave, pitch, and roll
-

## What's Included in Your Kit

---

**V200n kit** Table 1-1 lists the parts included with your V200n Compass. The V200n GNSS Compass and a NMEA 2000 cable are the only two required components.

**Note:** The V200n's parts comply with IEC 60945 Section 4.4: "Exposed to the weather."

---

**V200n Parts list** The following table lists the part numbers with description of the V200n.

**Table 1-1: V200n Parts list**

<b>Part No.</b>	<b>Description</b>
940-3140-11	HGNSS SA V200n SX6
804-0166-20	V200n, SX6, HGNSS
940-3151-11	HGNSS SA V200n (OEM - Unbranded)
804-0166-10	V200n, SX6, OEM

All of the following are accessory items available for purchase separately from your V200n.

**Table 1-2: V200n Accessory list**

<b>Part No.</b>	<b>Description</b>
710-0162-10	V200 Surface Mounting Kit
710-0166-10	V200 Pole Mounting Kit
710-0167-10	V200 Complete Mounting Kit

---

## Using PocketMax to Communicate with the V200n

---

### **Using PocketMax to communicate with the V200n**

Hemisphere's PocketMax is a free utility program that runs on your Windows PC or Windows mobile device. Simply connect your Windows device to the V200n via the COM port and open PocketMax.

The screens in PocketMax easily interface with the V200n:

- configure GNSS message output and port settings
- configure the receiver
- record various types of data
- monitor the V200n's status and function

PocketMax is available for download from the [Hemisphere GNSS website](#). Use the following steps to set up the V200n communication with PocketMax.

---

*Continued on next page*

## Using PocketMax to Communicate with the V200n, Continued

Using PocketMax to communicate with the V200n, continued

**Table 1-3: PocketMax Communication**

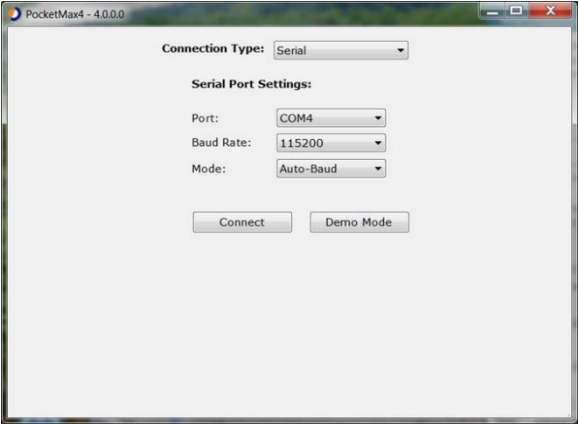
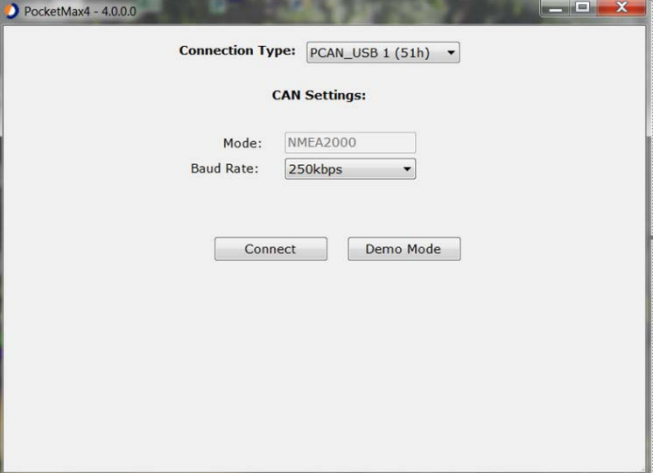
Step	Action
1	Open PocketMax. 
2	Change <b>Connection Type</b> from <b>Serial</b> CAN using the drop-down arrow and set the baud rate to 250kbps. 

*Continued on next page*

## Using PocketMax to Communicate with the V200n, Continued

Using PocketMax to communicate with the V200n, continued

**Table 1-3: PocketMax Communication (continued)**

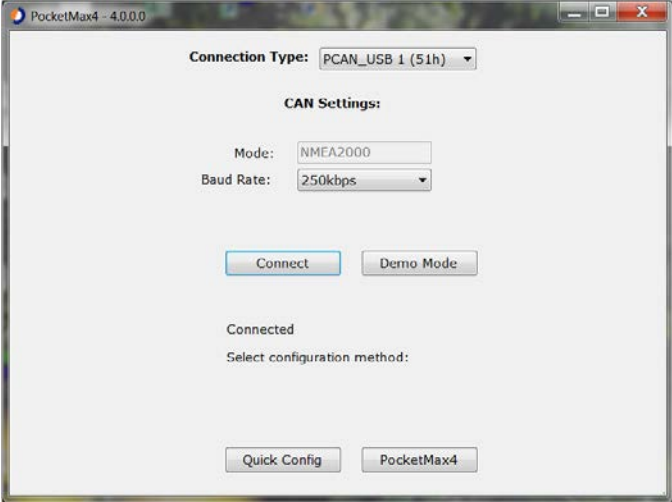
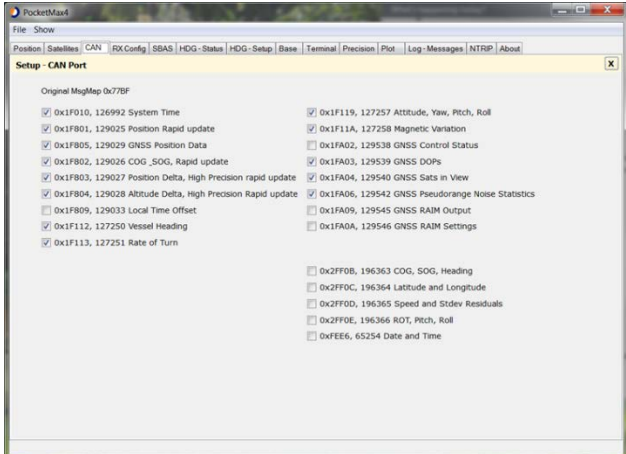
Step	Action
3	<p>Click <b>Connect</b>.</p>  <p><b>Quick Config</b> configures your receiver only.</p> <p><b>PocketMax</b> configures the receiver and shows your position and heading status.</p>
4	<p>Turn <b>ON/OFF</b> messages in the <b>CAN</b> tab.</p> 

*Continued on next page*



## Using PocketMax to Communicate with the V200n, Continued

Using  
PocketMax to  
communicate  
with the V200n,  
continued

**Table 1-3: PocketMax Communication (continued)**

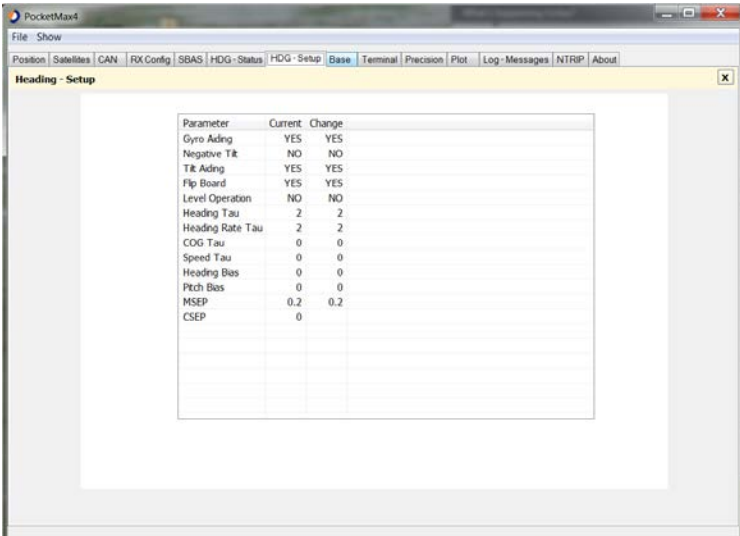
Step	Action
5	<p>The <b>Heading-Setup</b> screen features the following tabs:</p> <ul style="list-style-type: none"> <li>• <b>Position</b>-displays your position</li> <li>• <b>Satellites</b>-displays satellites tracking</li> <li>• <b>HDG-Status</b>-displays your heading</li> <li>• <b>HDG-Setup</b>-adjust your TAU values</li> </ul> 

## Firmware Upgrades

**Overview** Periodically, Hemisphere GNSS releases firmware updates to improve performance, fix bugs, or add new features to a product. To update the firmware on the V200n, use the Hemisphere Upgrade Suite.

**Hemisphere Upgrade Suite** Use Hemisphere Upgrade Suite by performing the following steps:

**Table 1-4: Hemisphere Upgrade Suite**

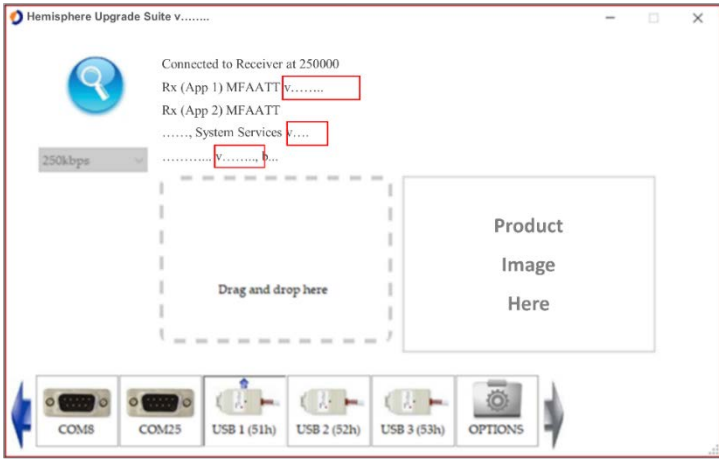
Step	Action
1	Connect the V200n to your computer with either a GridConnect PCAN-USB adapter or a Kvaser CAN to USB adapter.
2	Open Upgrade Suite. and verify that the version is <b>v. 99.1.3.10</b> or later.  
3	Ensure the baud rate is set to 250kbps, then click the “USB 1 (51h)” icon to open the USB port.  

*Continued on next page*

## Firmware Upgrades, Continued

Hemisphere Upgrade Suite, continued

**Table 1-4: Hemisphere Upgrade Suite (continued)**

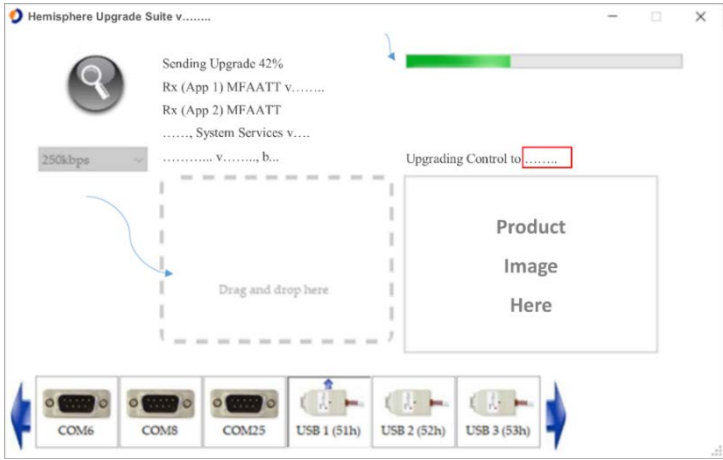
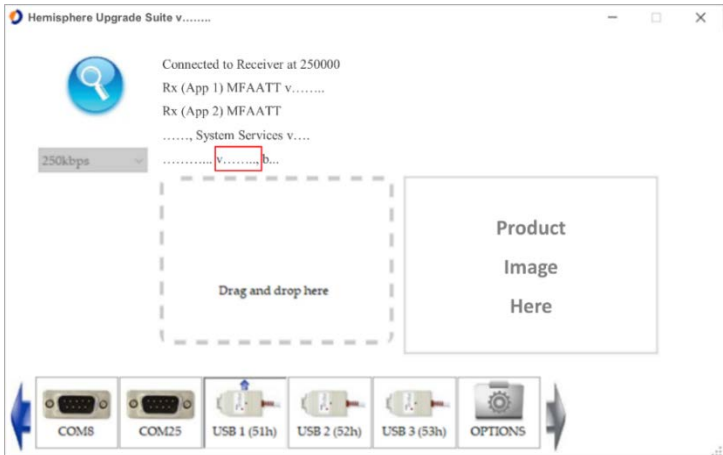

Step	Action
4	<p>If you need to update the <b>N2K/Menu firmware</b>, click on the magnifying glass to find and select the <b>N2K/Menu firmware file</b>, then drag and drop the file into the “Drag and drop here” section. The progress bar and text below will indicate the status of the upload.</p> 
5	<p>Verify the right <b>N2K/Menu firmware</b> has been loaded in the last line of text above the “Drag and drop here” section.</p> 

*Continued on next page*

## Firmware Upgrades, Continued

Hemisphere Upgrade Suite, continued

**Table 1-4: Hemisphere Upgrade Suite (continued)**



Step	Action
6	<p>If you need to update the <b>GNSS firmware</b>, click on the magnifying glass to find and select the <b>GNSS firmware file</b>, then drag and drop the file into the “Drag and drop here” section. The progress bar and text below will indicate the status of the upload.</p>  <p>Once completed, the “Rx (App1)” will be listed below “Rx (App2)”, and “Rx (App2)” will indicate that App2 still needs to be updated to the correct GNSS firmware version. Drag and drop the FW file to the box.</p> 

*Continued on next page*

## Firmware Upgrades, Continued, Continued

Hemisphere Upgrade Suite, continued

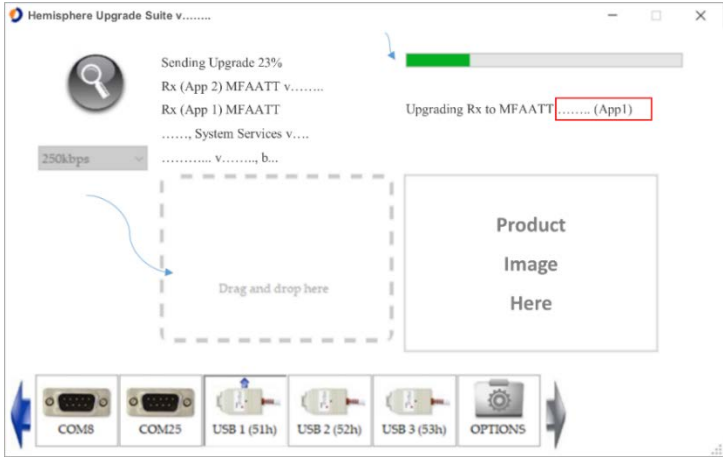
**Table 1-4: Hemisphere Upgrade Suite (continued)**

Step	Action
7	<p>If the App1 update doesn't automatically start, after the app swap, again drag and drop the <b>GNSS firmware</b> file into the "Drag and drop here" section. The progress bar and text below indicate the status of the upload.</p> 
8	<p>Once completed, the "Rx (App1)" is again listed above "Rx (App2)" and shows the correct firmware version.</p> 

## Chapter 2: Mounting the V200n

### Overview

---

**Introduction** This chapter provides instructions on how to mount your V200n Compass.

---

### Contents

	Topic	See Page
	Mounting the V200n	23
	Surface-mounting the V200n	35
	Pole-mounting the V200n	40

---

## Mounting the V200n

---

### Introduction

This section provides information on mounting the V200n in the optimal location, orientation considerations, environmental considerations, and other mounting options.

---

### GNSS satellite reception

When deciding where to mount the V200n, consider the following satellite reception recommendations:

- Ensure there is a clear view of the sky available to the V200n, so the GNSS and L-band satellites are not masked by obstructions that may reduce system performance.
- Position is based off the primary GNSS antenna located on located on the end opposite the recessed arrow on the underside of the enclosure.
- Locate any transmitting antennas away from the V200n by at least a few meters to ensure tracking performance is not compromised.
- Ensure cable length is adequate to route into the vessel to reach a breakout box or terminal strip.
- Do not locate the antenna where environmental conditions exceed those specified in [Appendix B, Technical Specifications](#) of this document.



**Figure 2-1: V200n Underside with recessed arrow**

---

*Continued on next page*

## Mounting the V200n, Continued

### VHF interference

VHF interference from such devices as cellular phones and radio transmitters may interfere with GPS operation, however the Vector compass can still track other constellations, maintaining heading and position.

For example, if installing the V200n near marine radios, consider the following:

- VHF marine radio working frequencies (Channels 1 to 28 and 84 to 88) range from 156.05 to 157.40 MHz. The L1 GPS working center frequency is 1575.42 MHz. The bandwidth is +/- 2MHz to +/- 10 MHz, which is dependent on the GNSS antenna and receiver design.
- VHF marine radios emit strong harmonics. The 10th harmonic of VHF radio, in some channels, falls into the GPS working frequency band, which may cause the Signal-to-Noise Ratio (SNR) of GNSS to degrade significantly.
- The radiated harmonic signal strength of assorted brands/models varies.
- Follow VHF radio manufacturers' recommendations on how to mount their radios and what devices to keep a safe distance away.
- Handheld 5W VHF radios may not provide suitable filtering and may interfere with the V200n's operation if too close.

Before installing the Vector Compass, use the following diagram to ensure there are no nearby devices that may cause VHF interference.

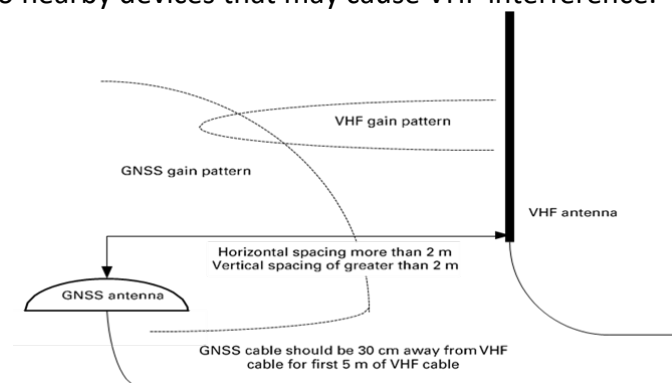

**Figure 2-2: V200n distance from nearby VHF radios**

*Continued on next page*



## Mounting the V200n, Continued

---

### Environmental considerations

Hemisphere Vector Compasses are designed to withstand harsh environmental conditions. Adhere to the following limits when storing and using the V200n:

- Operating temperature: -30°C to +70°C (-22°F to +158°F)
  - Storage temperature: -40°C to +85°C (-40°F to +185°F)
  - Humidity: 95% non-condensing
- 

### Mounting orientation

The V200n outputs heading, pitch, and roll readings regardless of the orientation of the antennas. The relation of the antennas to the vessel's axis determines if you need to enter a heading, pitch, or roll bias. The primary antenna is used for positioning and the primary and secondary antennas, working in conjunction, output heading, pitch, and roll values.

The top of the V200n enclosure incorporates a sight design feature to help you align the enclosure on your vessel. Alignment accuracy is approximately +/- 2°.

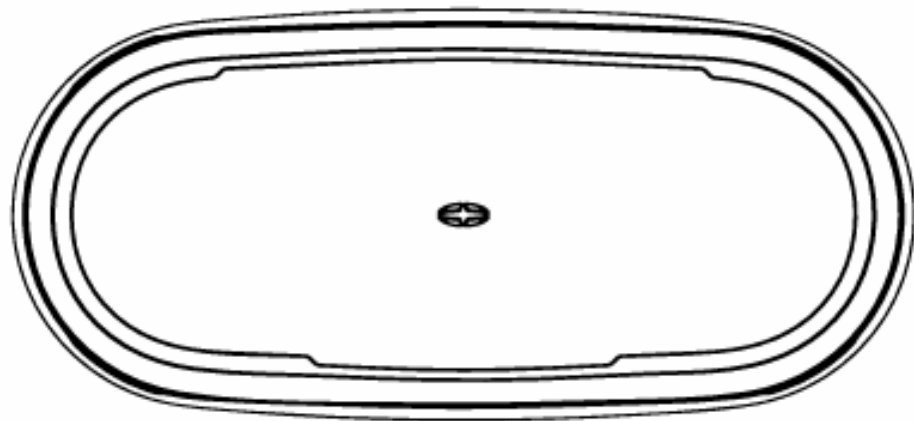

**Figure 2-3: Shorter design element**

**Note:** Regardless of which mounting orientation you use, the V200n provides the ability to output the heave of the vessel. This output is available using either MSGID 0x0031 (NMEA 2000) or **\$GPHEV** (using the PocketMax Terminal window). For more information on this message refer to the [Hemisphere GNSS Technical Reference Manual](#).

---

*Continued on next page*

## Mounting the V200n, Continued

---

### Parallel orientation

Parallel installation orients the V200n parallel to, and along the centerline of, the axis of the vessel. **This provides a true heading.** In this orientation:

- If you use a gyrocompass and there is a need to align the Vector Compass, you can enter a heading bias in the V200n to calibrate the physical heading to the true heading of the vessel.
  - You may need to adjust the pitch/roll output to calibrate the measurement if the Vector is not installed in a horizontal plane.
- 

### Perpendicular orientation

You can also install the antennas, so they are oriented perpendicular to the centerline of the vessel's axis. In this orientation:

- Enter a heading bias of +90° if the primary antenna is on the starboard side of the vessel and -90° if the primary antenna is on the port side of the vessel.
  - Configure the receiver to specify the GNSS Compass is measuring the roll axis using either MSGID 0x003D (NMEA 2000) or **\$JATT,ROLL,YES** (using the PocketMax Terminal window).
  - Enter a roll bias to properly output the pitch and roll values.
  - You may need to adjust the pitch/roll output to calibrate the measurement if the Vector is not installed in a horizontal plane.
- 

*Continued on next page*

## Mounting the V200n, Continued

---

### Mounting orientation example

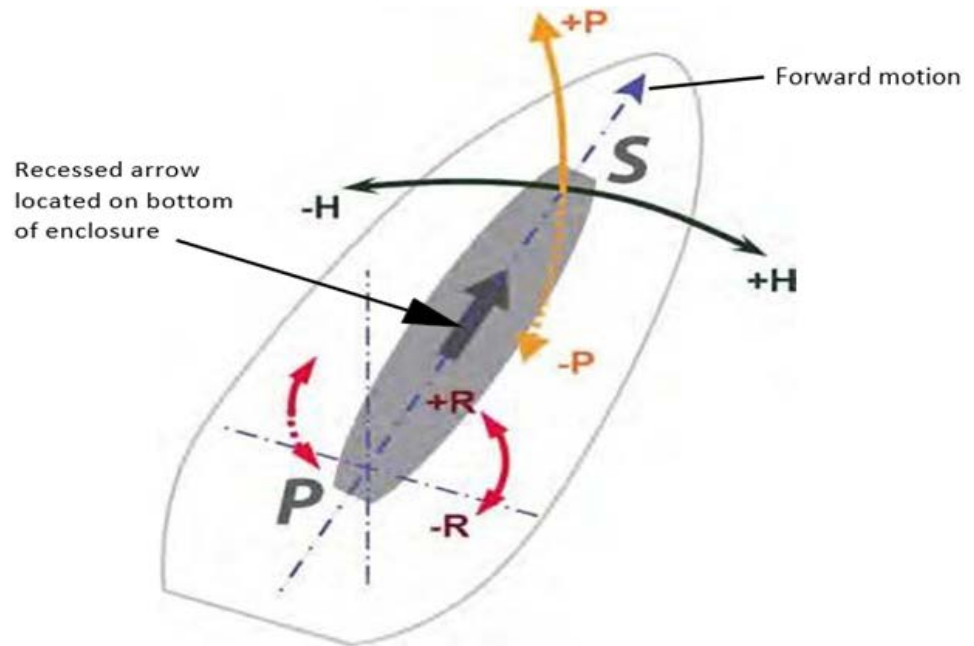

**Figure 2-4: Recommended orientation and resulting signs of HPR values**

---

*Continued on next page*

## Mounting the V200n, Continued

---

Mounting orientation example, continued

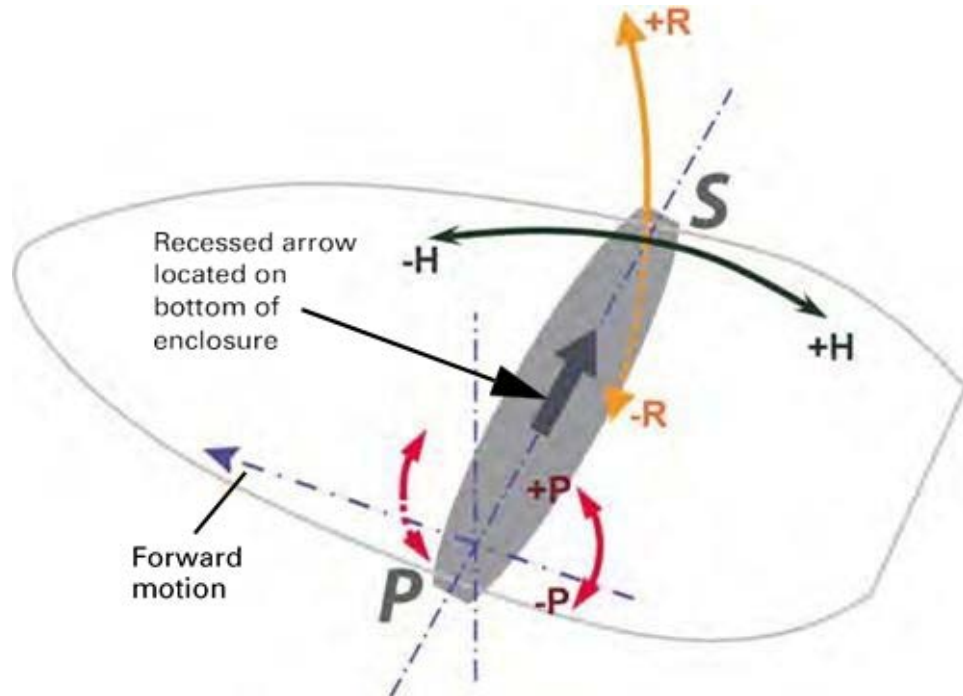

Figure 2-5: Alternate orientation and resulting signs of HPR values

*Continued on next page*

## Mounting the V200n, Continued

### V200n dimensions

Figure 2-6 illustrates the physical dimensions of the V200n GNSS Compass.

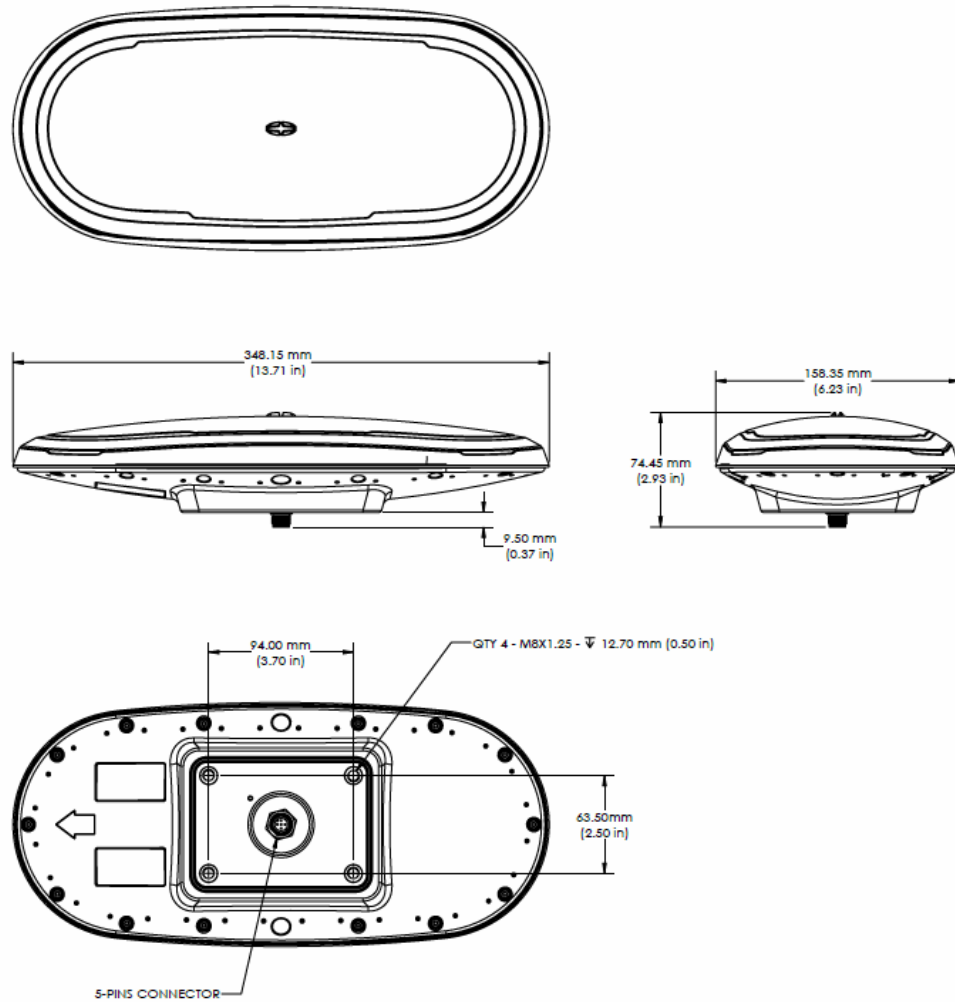

Figure 2-6: V200n dimensions

*Continued on next page*

## Mounting the V200n, Continued

### V200n mounting with pole mount accessory

Figure 2-7 illustrates the physical dimensions of the V200n GNSS Compass when mounted using the pole mount accessory.

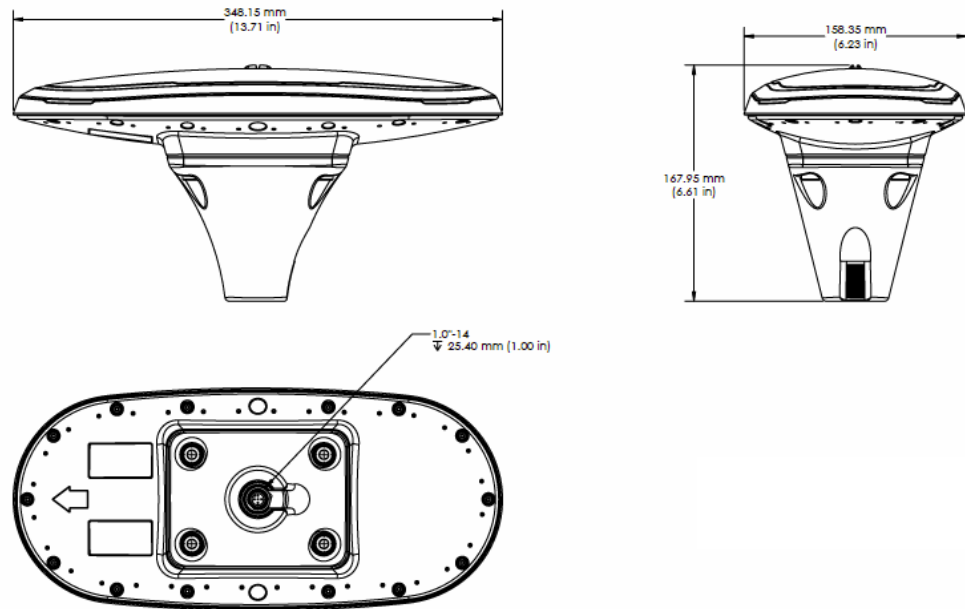

Figure 2-7: V200n with pole mount accessory

*Continued on next page*

## Mounting the V200n, Continued

### V200n mounting with low-profile surface mount accessory

Figure 2-8 illustrates the physical dimensions of the V200n GNSS Compass when mounted using the low-profile mount accessory.

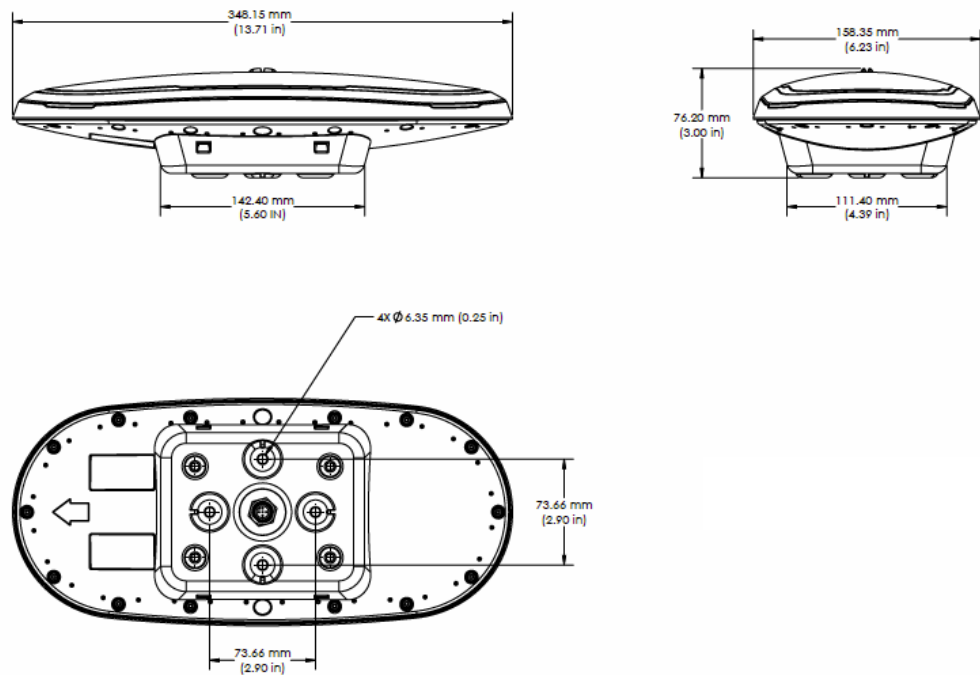

**Figure 2-8: V200n with low-profile surface mount accessory**

*Continued on next page*

## Mounting the V200n, Continued

### V200n mounting with high-profile surface mount accessory

Figure 2-9 illustrates the physical dimensions of the V200n GNSS Compass when mounted using the high-profile mount accessory.

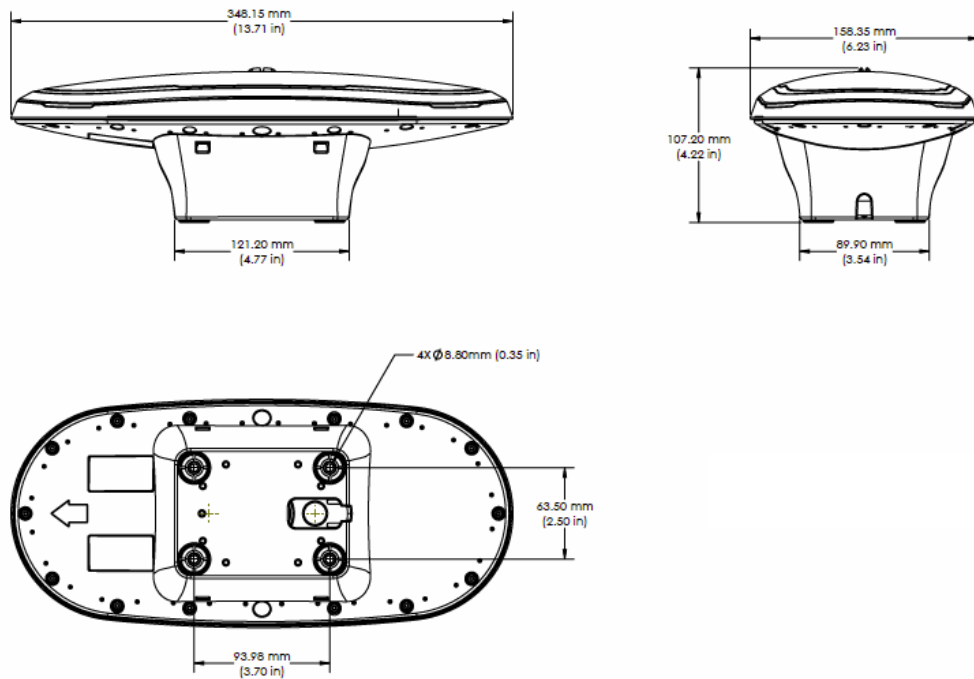

**Figure 2-9: V200n with high-profile mount accessory**

### Mounting alignment

If you have another accurate source of heading data on your vessel, such as a gyrocompass, you may use its data to correct for a bias in V200n alignment within the V200n software configuration.

Alternatively, you can physically adjust the heading of the V200n so that it renders the correct heading measurement or add a software offset.

*Continued on next page*



## Mounting the V200n, Continued

### NMEA 2000 cable considerations

Before mounting the V200n, consider the following regarding NMEA 2000 cable routing:

<b>Do</b>	<b>Do not</b>
Ensure cable reaches appropriate power source.	Run cables in areas of excessive heat.
Keep cable away from corrosive chemicals.	Run cables through a door or window jams.
Connect to a data storage device, computer, or other device that accepts GNSS data.	Crimp or excessively bend the cable.
Keep cable away from rotating machinery.	Place tension on the cable.
Remove unwanted slack from the cable at the V200n end.	
Secure along the cable route using plastic wrapping.	

**⚠ WARNING:**  
**Improperly installed cable near machinery can be dangerous.**

*Continued on next page*

## Mounting the V200n, Continued

---

**NMEA 2000  
cable  
considerations,  
continued**

Use the following steps to connect the NMEA 2000 cable.

**Table 2-1: Connect NMEA 2000 cable**

Step	Action
1	Align the cable connector keyway with the V200n connector key.
2	Rotate the cable ring clockwise, hand-tightening until it is firmly secured to the unit (see Figure 3-1).

**⚠ WARNING:** When installing the V200n, hand-tighten only. Damage resulting from over-tightening is not covered by the warranty.

**Note:** V200n performance is subject to the unit being installed in a location and environment as specified in this User Guide and using a NMEA 2000 certified cable.

**Mounting  
options**

The V200n offers four different mounting options:

- Bottom-up Surface Mounting for straight cable
- Top-down Surface Mounting for straight cable
- Top-down Surface Mounting for right-angle cable
- Pole Mounting

**Note:** Hemisphere GNSS does not supply mounting surface hardware or a mounting pole. You must supply the appropriate mounting hardware required to complete V200n installation.

---

## Surface-mounting the V200n

---

### Surface-mounting the V200n

Be mindful of the following when planning your installation:

- If you need the GNSS-assisted roll measurement, install the V200n perpendicular to the vessel's axis. If you do not need this measurement, install the V200n parallel with the vessel's axis.
  - Hemisphere GNSS does not supply mounting surface hardware or a mounting pole. You must supply the appropriate hardware or mounting pole required to complete V200n installation.
  - You can enter a software offset to accommodate for a heading measurement bias due to installation.
  - The flat surface may be fabricated per your installation, an off-the-shelf item (such as a radar mounting plate), or an existing surface on your vessel.
- 

### Surface-mounting the V200n from the bottom up for straight cable

Complete the following steps to surface-mount the V200n from the bottom up.

**Table 2-2: Bottom-up, Surface-mounting the V200n**

Step	Action
1	Determine the desired location and proper orientation for the V200n. See <a href="#">Mounting Orientation</a> for information on determining the desired orientation.
2	Go to the <a href="#">HGNSS website/Technical Documentation/V200 Mounting Template</a> .
3	Use the supplied V200 Mounting Template drawing (from Step 2) or photocopy the bottom of the V200n to plan the mounting hole locations. If using a photocopy, make sure it is scaled one-to-one with the mounting holes on the bottom of the V200n.
4	If required, use a center punch to mark the hole centers on the mounting surface, then drill the mounting holes with a 9mm (.35 in) bit appropriate for the surface.

*Continued on next page*

## Surface-mounting the V200n, Continued

Surface-mounting the V200n, continued

**Table 2-2: Bottom-up, Surface-mounting the V200n (continued)**

Step	Action		
5	Place the V200n over the mounting holes and insert the mounting screws through the bottom of the mounting surface into the V200n.		
6	<p>Tighten to a torque of 8 - 10 lbs.-ft. The maximum thread depth engagement must be no more than 0.50 in!</p> <table border="1" data-bbox="581 726 1401 804"> <tr> <td data-bbox="581 726 797 804"><b>⚠ WARNING:</b></td> <td data-bbox="797 726 1401 804"><b>Damage resulting from over-tightening is not covered by the warranty.</b></td> </tr> </table>	<b>⚠ WARNING:</b>	<b>Damage resulting from over-tightening is not covered by the warranty.</b>
<b>⚠ WARNING:</b>	<b>Damage resulting from over-tightening is not covered by the warranty.</b>		

*Continued on next page*

## Surface-mounting the V200n, Continued

Surface-mounting the V200n from the top down for straight cable and for right-angle cable

Complete the following steps to surface-mount the V200n from the top down.

**Table 2-3: Top down, Surface-mounting the V200n**





Step	Action
1	<p>Secure the Surface Mount Adapter (676-0043-10) to the V200n using the supplied mounting hardware. Tighten to a torque of 8 - 10 lbs.-ft. The maximum thread depth engagement must be no more than 0.50 in!</p> <div data-bbox="773 802 1208 1024" data-label="Image"> <p>A white, rectangular plastic surface mount adapter with a central circular cutout and several smaller circular holes around the perimeter. It has a slightly raised, tray-like structure.</p> </div> <p data-bbox="755 1066 1227 1136"><b>Figure 2-10: Surface Mount Adapter (676-0043-10)</b></p> <div data-bbox="751 1178 1229 1360" data-label="Image"> <p>The white surface mount adapter is shown mounted onto a white, oval-shaped V200n device. The adapter is secured to the device with several screws around its perimeter.</p> </div> <p data-bbox="634 1402 1344 1436"><b>Figure 2-11: Surface Mount Adapter secured to V200n</b></p>
2	<p>Determine the desired location and proper orientation for the V200n. See <a href="#">Mounting Orientation</a> for information on determining the desired orientation.</p>

*Continued on next page*

## Surface-mounting the V200n, Continued

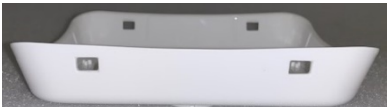
Surface-mounting the V200n from the top down for straight cable and for right-angle cable, continued

**Table 2-3: Top down, Surface-mounting the V200n (continued)**







Step	Action	
3	Select the applicable surface mount:	
	Select this surface mount if you will thread the cable straight down.	Select this surface mount if you will thread the cable towards the back of the unit.
		
<b>Figure 2-12: V200 Low-Profile Surface Mount (676-0041-10)</b>	<b>Figure 2-13: V200 Right-Angle Surface Mount (676-0042-10)</b>	
4	Place the surface mount in the desired location on the installation surface.	
5	If required, use a center punch to mark the hole centers, then drill the mounting holes with bit appropriate for the surface.	
	<b>Note:</b> The diameter of the 676-0041-10 mounting holes is 6.4 mm (.25 in)	<b>Note:</b> The diameter of the 676-0042-10 mounting holes is 9 mm (.35 in)
		
<b>Figure 2-14: 676-0041-10 Mounting Holes</b>	<b>Figure 2-15: 676-0042-10 Mounting Holes</b>	
6	Secure the mount to the installation surface. Tighten to a maximum torque of 10 lbs.-ft.	

*Continued on next page*

## Surface-mounting the V200n, Continued

Surface-mounting the V200n from the top down for straight cable and for right-angle cable, continued

**Table 2-3: Top down, Surface-mounting the V200n (continued)**



Step	Action				
7	Thread the cable into through the surface mount, then connect the cable to the unit.				
8	<p>Carefully secure the mount to the V200n by placing it into the surface mount until the four latches snap into place, first on one side, and then the other.</p> <table border="1" data-bbox="581 716 1393 936"> <thead> <tr> <th data-bbox="581 716 992 753">Low-Profile</th> <th data-bbox="992 716 1393 753">Right-Angle</th> </tr> </thead> <tbody> <tr> <td data-bbox="581 753 992 936">  </td> <td data-bbox="992 753 1393 936">  </td> </tr> </tbody> </table> <p><b>Figure 2-16: Adapters with both sides secured</b></p>	Low-Profile	Right-Angle		
Low-Profile	Right-Angle				
					
	<p><b>Note:</b> To remove the V200n, simply reverse the process by pushing in the clips on one side, at which point the V200n can easily be removed.</p>				

## Pole-mounting the V200n

### Pole-mounting the V200n

Complete the following steps to pole-mount the V200n:

**Table 2-4: Pole-mounting the V200n**

Step	Action		
1	Determine the desired location and proper orientation for the V200n. See <a href="#">Mounting Orientation</a> for information on determining the desired orientation.		
2	<p>Thread the jam nut onto the 1-inch pole, then thread the pole mount.</p>  <p><b>Figure 2-17: Pole mount with jam nut loosely threaded</b></p> <table border="1" data-bbox="581 1129 1401 1209"> <tr> <td data-bbox="581 1129 797 1209"><b>⚠ WARNING:</b></td> <td data-bbox="797 1129 1401 1209"><b>Do not tighten the pole mount to more than 4 lbs.-ft.</b></td> </tr> </table>	<b>⚠ WARNING:</b>	<b>Do not tighten the pole mount to more than 4 lbs.-ft.</b>
<b>⚠ WARNING:</b>	<b>Do not tighten the pole mount to more than 4 lbs.-ft.</b>		
3	Thread the cable either through the hollow pole or through the opening in the pole mount.		
4	<p>Connect the cable to the V200n, then secure the pole mount to the V200n using the supplied mounting hardware. Tighten to a torque of 8 - 10 lbs.-ft. The maximum thread depth engagement must be no more than 0.50 in!</p>  <p><b>Figure 2-18: Pole mount secured to V200n</b></p>		

*Continued on next page*



## Pole-mounting the V200n, Continued

Pole-mounting the V200n, continued

**Table 2-4: Pole-mounting the V200n (continued)**

Step	Action
5	<p>Verify the orientation of the unit, then tighten the jam nut to the bottom of the pole mount to a torque of 8 – 10 lbs.-ft.</p> <div data-bbox="799 632 1182 957" data-label="Image">  </div> <p><b>Figure 2-19: Pole mount with jam nut tightly threaded to secure V200n orientation</b></p>

## Chapter 3: Connecting the V200n Compass

### Overview

---

**Introduction** This chapter provides instructions on how to connect your V200n GNSS compass.

---

### Contents

	<b>Topic</b>	<b>See Page</b>
	Ports	43
	WebUI	44
	Connecting the V200n to External Devices	57

---

## Ports

---

### Overview

The V200n offers NMEA 2000 functionality.

---

### NMEA 2000 port

Refer to [Appendix C](#) for details regarding supported NMEA 2000 messages.

---

## WebUI

---

**Introduction** The WebUI of the HGNSS V200n allows the user to configure the receiver and radio with a WiFi-capable computer or mobile device.

**Note:** WebUI functionality applies only to V200n and V200s units that are Bluetooth/WiFi-capable and Bluetooth/WiFi-activated.

The typical WiFi range is expected to be up to 30 feet (10m). Ideally the user should be in close range to the receiver.

The WebUI offers easy product status review, configuration, and GNSS Firmware updates without the need for a wired cable connection.

---

**WiFi Connection** To use the WebUI, a WiFi connection must be established with the HGNSS V200n receiver. To connect the mobile device to the receiver over WiFi:

1. Ensure WiFi is enabled on the mobile device
2. Identify the SSID of the V200n receiver as [HGSS+8digit ESN]
3. Connect to the WiFi network
4. The default WiFi password is “hgnss1234”

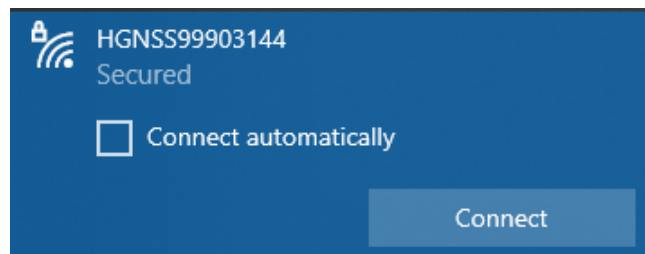

**Access WebUI** The WebUI utilizes an IP address with a standard internet browser. To access the V200n WebUI start page:

1. Open the internet browser
2. Enter <http://192.168.100.1/>
3. Access the start page of the V200n WebUI

**Note:** All standard internet browsers can be used to operate the WebUI (i.e., Google Chrome, Firefox, Microsoft Edge).

*Continued on next page*

## WebUI, Continued

### Status page

The **Status** page of the V200n WebUI provides a quick overview of the status of the receiver.

It includes information for **Time, Position, Heading, Precision, Solution Status** and **L-Band/SBAS**.

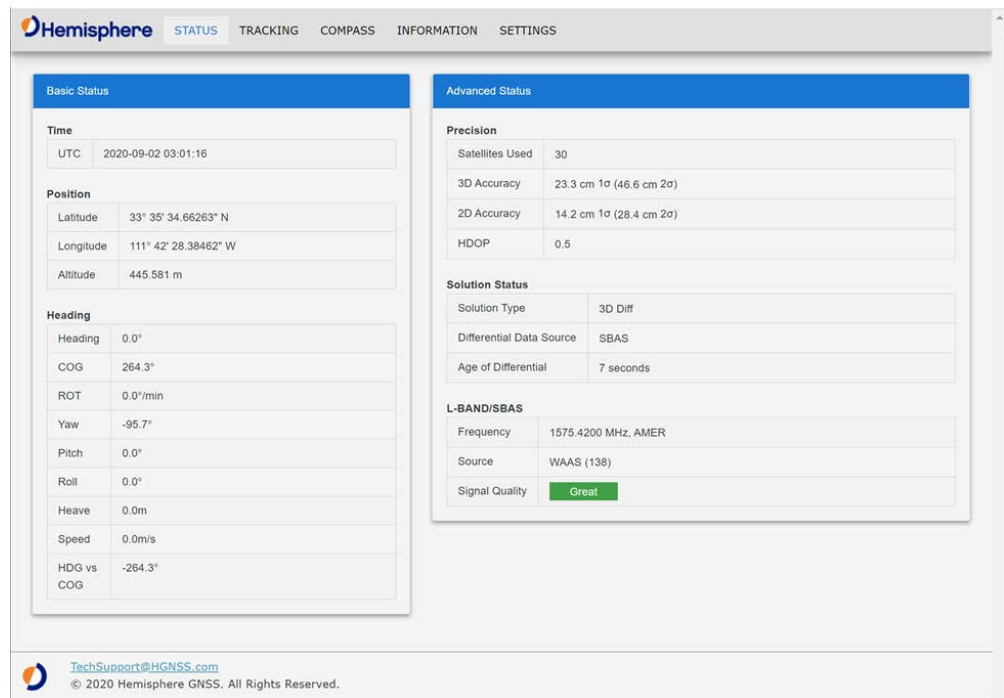

Basic Status		Advanced Status	
<b>Time</b>			
UTC	2020-09-02 03:01:16		
<b>Position</b>			
Latitude	33° 35' 34.66263" N		
Longitude	111° 42' 28.38462" W		
Altitude	445.581 m		
<b>Heading</b>			
Heading	0.0°		
COG	264.3°		
ROT	0.0°/min		
Yaw	-95.7°		
Pitch	0.0°		
Roll	0.0°		
Heave	0.0m		
Speed	0.0m/s		
HDG vs COG	-264.3°		
<b>Precision</b>			
Satellites Used	30		
3D Accuracy	23.3 cm 1σ (46.6 cm 2σ)		
2D Accuracy	14.2 cm 1σ (28.4 cm 2σ)		
HDOP	0.5		
<b>Solution Status</b>			
Solution Type	3D Diff		
Differential Data Source	SBAS		
Age of Differential	7 seconds		
<b>L-BAND/SBAS</b>			
Frequency	1575.4200 MHz, AMER		
Source	WAAS (138)		
Signal Quality	Great		

TechSupport@HGNSS.com  
© 2020 Hemisphere GNSS. All Rights Reserved.

*continued on next page*

## WebUI, Continued

**Tracking page** The **Tracking** page of the WebUI provides an overview of the tracked signals for the V200n Smart Antenna.

The **Sky View** graphic shows the tracked satellites for the GPS, GLONASS, and BeiDou system and their current orientation.

The **Signal Chart** visualizes the SNR for each tracked signal with the help of a bar graph.

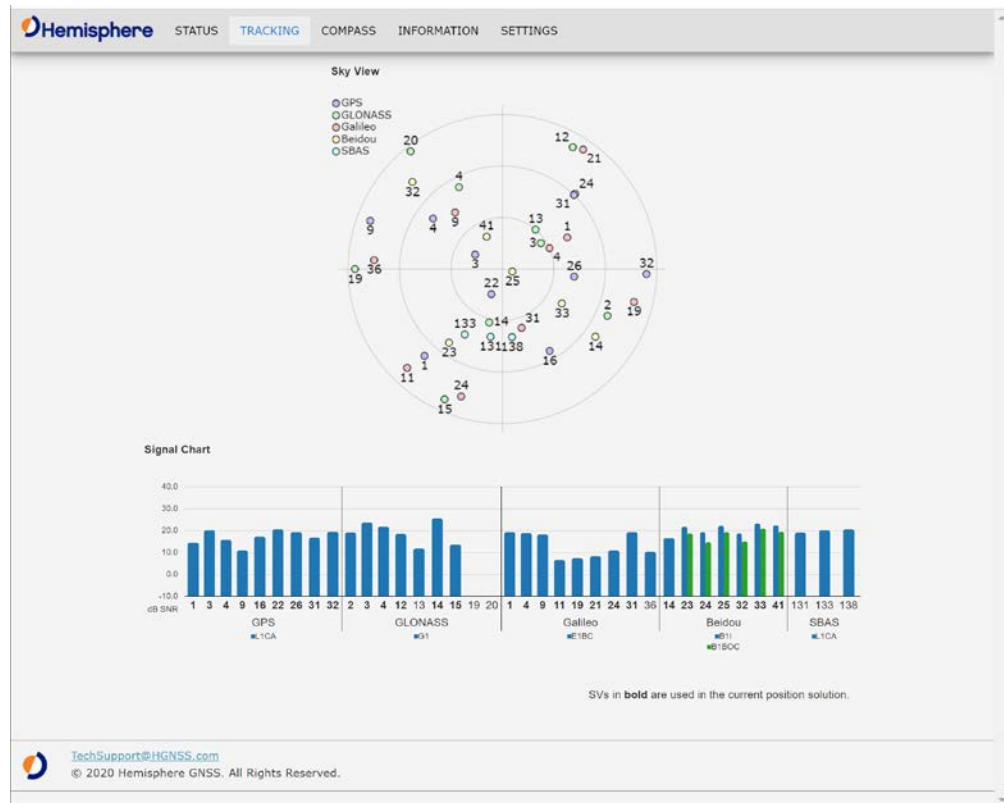

*Continued on next page*

## WebUI, Continued

**Compass page** The **Compass** page visualizes the GNSS heading of the V200n Smart Antenna while in motion.



**Note:** The provided V200n Smart Antenna heading will only provide a stable indication if the receiver is moving.

*Continued on next page*

## WebUI, Continued

### Information page

The WebUI **Information** page includes a general overview of the essential receiver information, including the **Electrical Serial Number (ESN)** of the receiver, **Board Type** and the installed **GNSS Firmware**.

The installed **Activations & Subscriptions** are shown. For time-based subscriptions, this includes the expiration date.

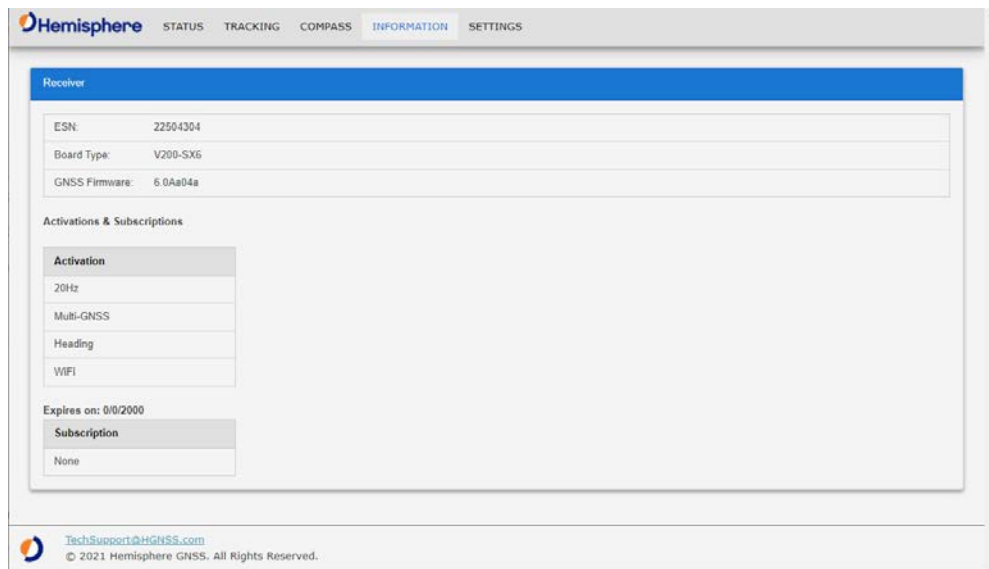

*Continued on next page*



## WebUI, Continued

---

- Settings page**      The **Settings** page has different tabs that include information for the following:
- System
  - WiFi\*
  - Heading
  - Serial
  - USB
  - File System
  - Atlas

\*The **WiFi** tab includes the **WiFi and Bluetooth Configuration** settings.

---

*Continued on next page*

## WebUI, Continued

### Settings page, System

The **System** tab within the **Settings** page of the WebUI allows the user to update GNSS Firmware and submit **Activation & Subscription** licenses.

To update the receiver GNSS firmware, the SW file can be selected using the **GNSS Firmware Update** menu. The update can be initiated by pressing the **Update** button. The **Status** and **Progress** information is available during the update process.

The **Activation & Subscription** menu can be used to enter new activation or subscription license codes and submit them to the receiver by pushing the **Update** button.

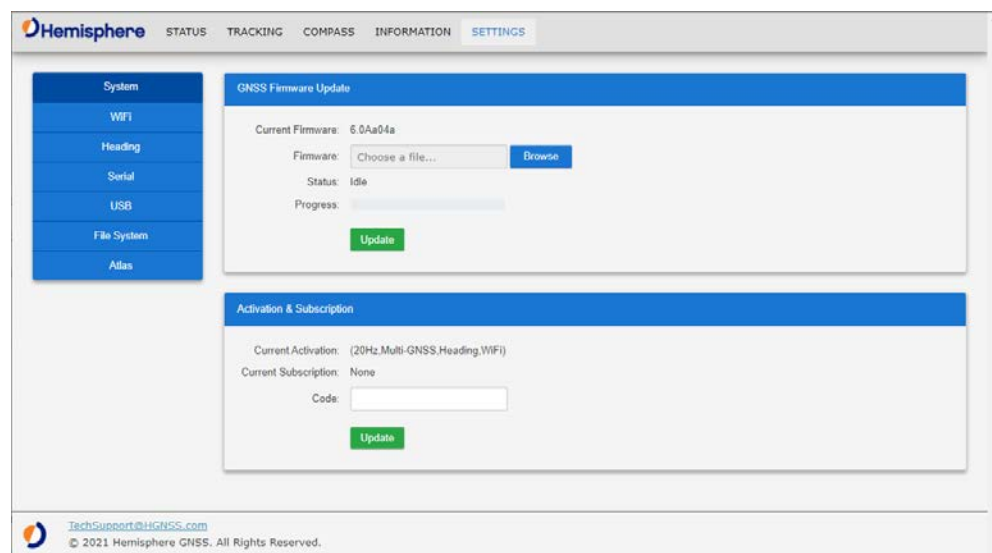

*Continued on next page*

## WebUI, Continued

### Settings page, Wi-Fi

The **Wi-Fi** tab allows you to adjust the **SSID** and create your own password.

Use the **Start Pairing Mode** to connect and configure your Bluetooth device to the V200n.

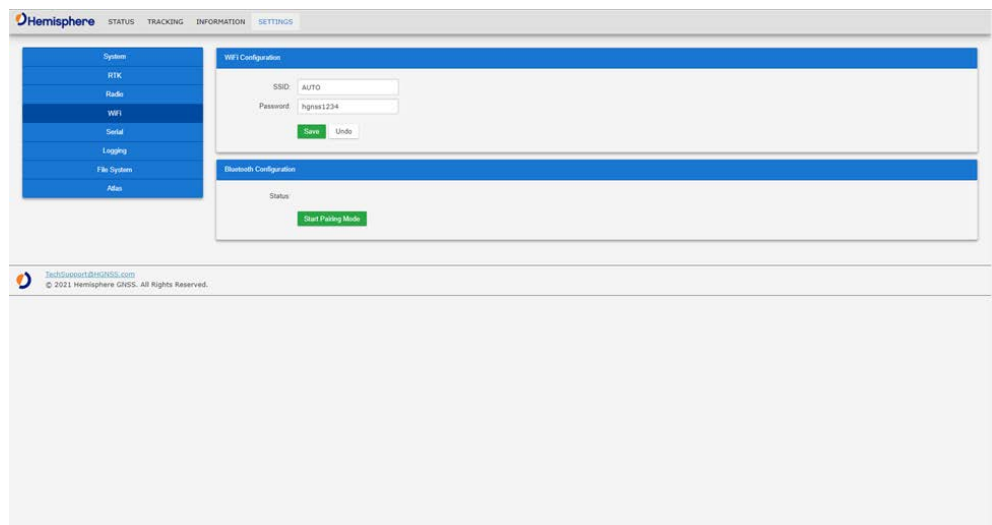

*Continued on next page*

## WebUI, Continued

**Settings page, Heading** The **Heading** tab within the **Settings** page allows the user to review and configure the Heading settings for the V200n Smart Antenna.

The **Heading Configuration Table** provides a list of the messages and settings: Heading Bias, Pitch Bias, Gyro Aiding, Neg Tilt, tilt Aiding, Level operation, Pitch/Roll Mode, Heading TAU, Heading Rate TAU, Course Over Ground (COG) TAU, Speed TAU, MSEP, CSEP, and Moving Baseline.

The **Heading Configuration** section allows the user to configure the desired Bias, Aiding, or TAU.

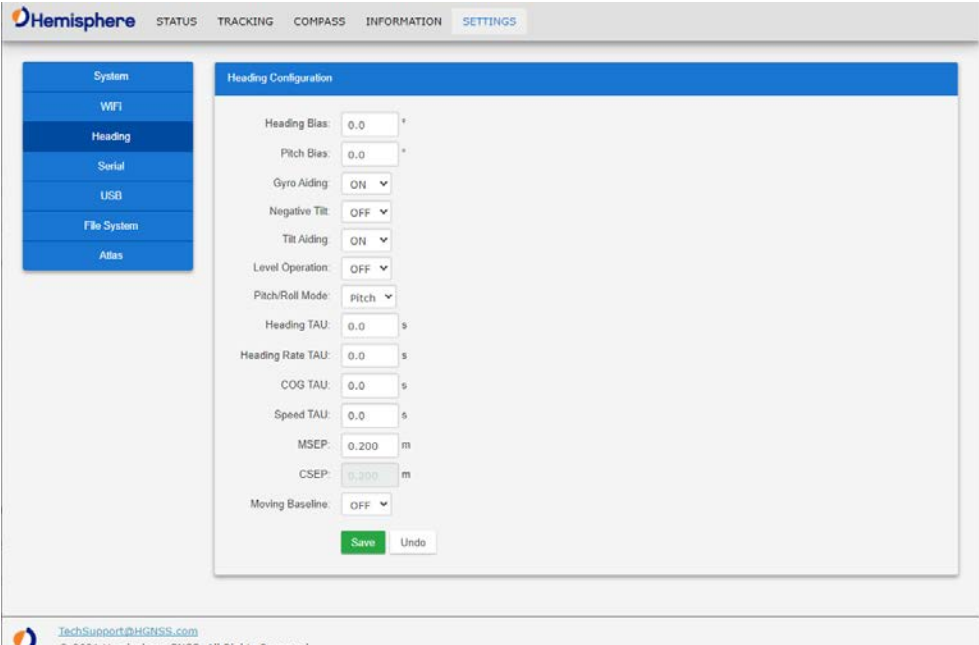

The screenshot shows the Hemisphere WebUI interface. At the top, there are navigation tabs: STATUS, TRACKING, COMPASS, INFORMATION, and SETTINGS. The SETTINGS tab is active. On the left, there is a sidebar menu with options: System, WIFI, Heading (selected), Serial, USB, File System, and Atlas. The main content area is titled "Heading Configuration" and contains the following settings:

Heading Bias:	0.0	°
Pitch Bias:	0.0	°
Gyro Aiding:	ON	
Negative Tilt:	OFF	
Tilt Aiding:	ON	
Level Operation:	OFF	
Pitch/Roll Mode:	Pitch	
Heading TAU:	0.0	s
Heading Rate TAU:	0.0	s
COG TAU:	0.0	s
Speed TAU:	0.0	s
MSEP:	0.200	m
CSEP:	5.300	m
Moving Baseline:	OFF	

At the bottom of the configuration area, there are "Save" and "Undo" buttons. The footer of the page includes the email [TechSupport@HGNSS.com](mailto:TechSupport@HGNSS.com) and the copyright notice: © 2021 Hemisphere GNSS. All Rights Reserved.

## WebUI, Continued

### Settings page, Serial

The **Serial** tab within the **Settings** page allows the user to review and configure the serial settings for Port A and Port B of the V200n Smart Antenna.

The **Message Output Table** lists the enabled messages according to the Output Rate per port.

The **Output Configuration** section allows the user to configure the desired NMEA or BIN message to output on the selected port. This menu also provides the option to turn off the serial communication completely for this port with the **Port Off** button.

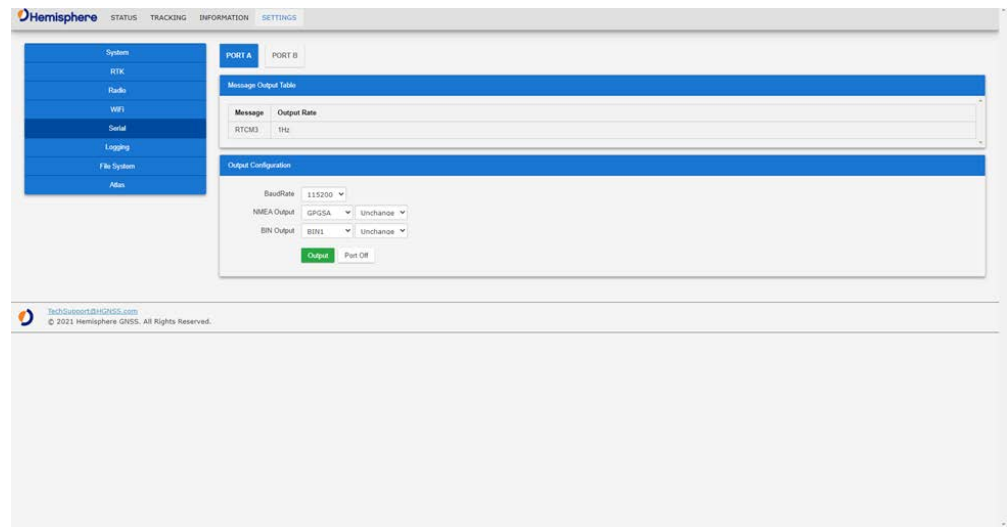

*Continued on next page*

## WebUI, Continued

### Settings page, USB

The **USB** tab within the **Settings** page allows the user to review and configure the serial settings for Port U of the V200n Smart Antenna.

The **Message Output Table** lists the enabled messages according to Output Rate per port.

The **Output Configuration** section allows the user to configure the desired NMEA or BIN message to output on Port U. This menu also provides the option to turn off the serial communication completely for this port with the **Port Off** button.

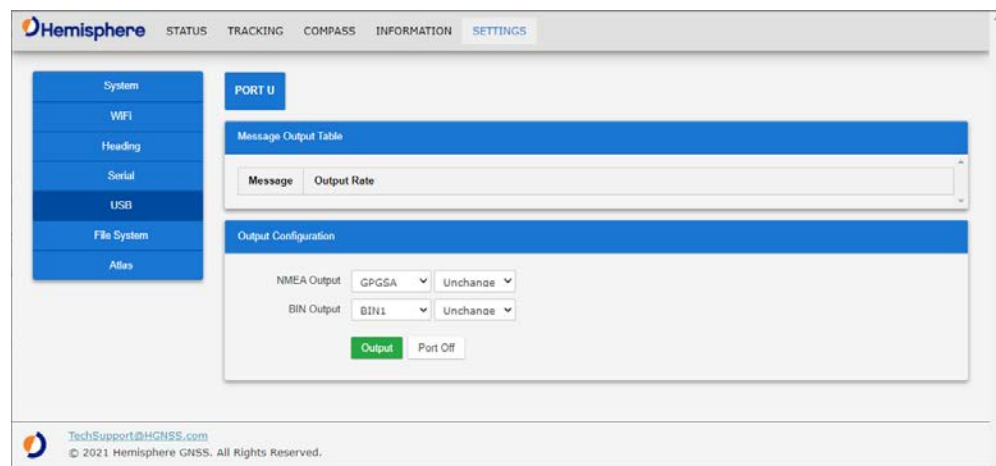

*Continued on next page*

## WebUI, Continued

### Settings page, File System

The **File System** tab allows you to download and upload logs for the V200n. This can be done by selecting the log from the files table and clicking the **Download** button.

To upload files, click the **Browse** button, select the file you wish to upload, and click the **Upload** button.

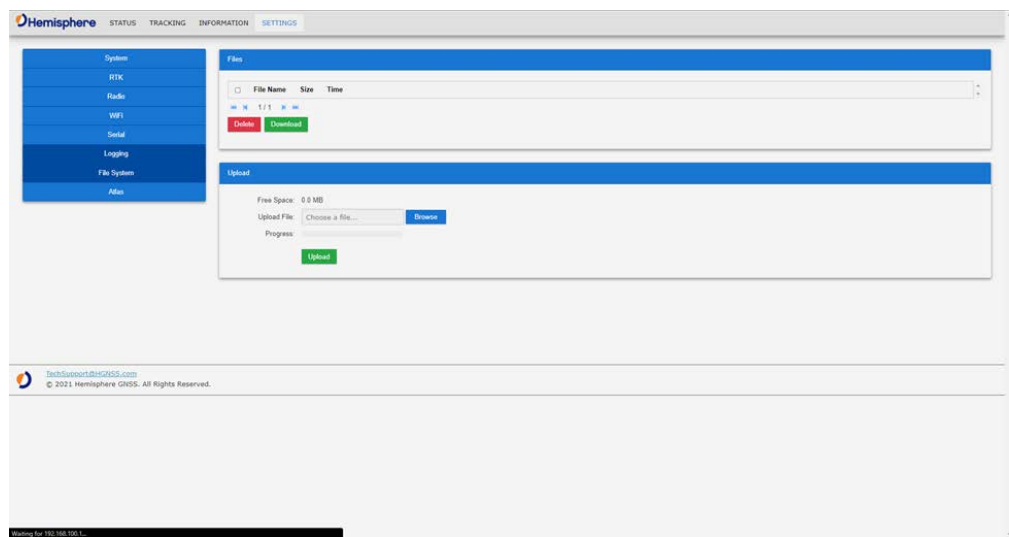

*Continued on next page*

## WebUI, Continued

### Settings page, Atlas

The **Atlas** tab within the **Settings** page of the WebUI allows users to configure the V200n receiver for the Atlas L-band correction service.

The Atlas L-band main menu supports configurations for **Use Corrections, Mode, Frequency** and **Baud Rate**. The desired changes can be saved by using the **Save** button or disregarded with the **Undo** button.

The **Atlas Datum** menu supports configurations for **Datum Type, Local Offset** and **Geodetic Offset**. The desired changes can be saved by using the **Save** button or disregarded with the **Undo** button.

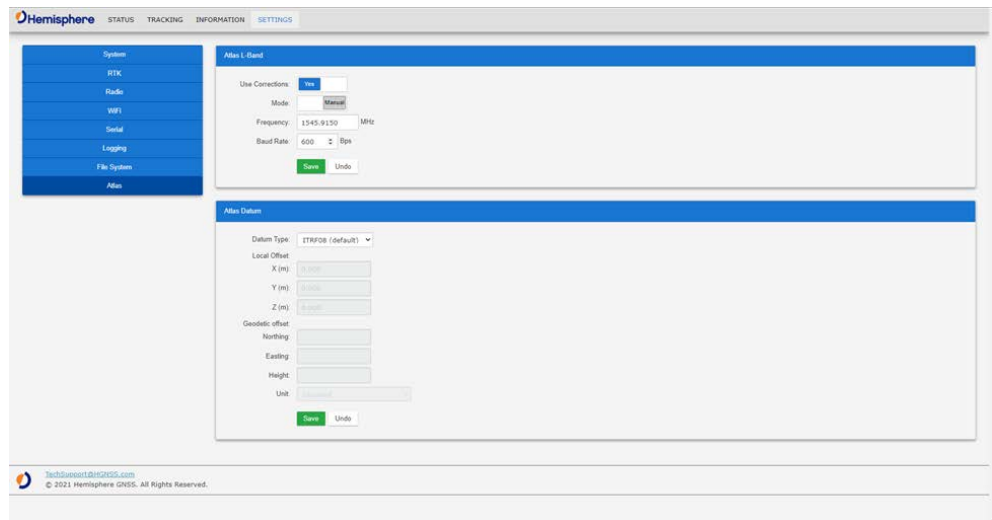



## Connecting the V200n to External Devices

### NMEA 2000 cable pin-out specifications

The V200n uses a standard NMEA 2000 5-pin connector and does not include internal CAN termination.

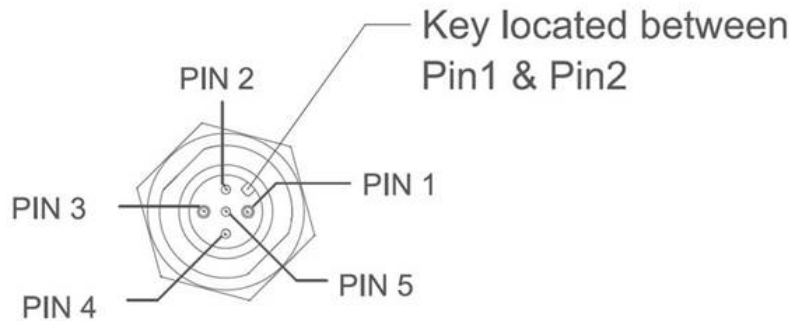

**Figure 3-1: V200n pin-out assignments**

Table 3-1 shows the cable pin-out specifications.

**Table 3-1: V200n Pin-out (Device Out)**

Pin	NMEA 2000 Mode (Device Out)
1	Shield
2	Power In
3	Power Ground
4	CAN Hi
5	CAN Lo

### Electrical isolation

The V200n's power supply is isolated from the communication lines and the PC-ABS plastic enclosure isolates the electronics mechanically from the vessel (addressing the issue of vessel hull electrolysis).

## Chapter 4: Understanding the V200n

### Overview

---

#### Introduction

The GNSS receiver begins tracking satellites when it powers up and is placed outside in an open area. Position and heading accuracy vary depending upon location and environment. Position performance can be improved with RTK or DGNS.

The following sections provide the steps to configure your V200n to use Atlas, SBAS, or RTK.

**Note:** Differential source and RTK status impact only positioning and heave. There is no impact to heading, pitch, or roll.

---

### Contents

	Topic	See Page
	GNSS Overview	59
	Differential Operation	60
	SBAS XE "SBAS" Tracking	61
	Atlas L-band	62
	Supplemental Sensors	63
	Time Constants	66

---

## GNSS Overview

---

**GNSS operation** The GNSS receiver is always operating, regardless of the DGNSS mode of operation. The following sections describe the general operation of the V200n's internal GNSS receiver.

**Note:** Differential source and status have no impact on heading, pitch, or roll. They only have an impact on positioning and heave.

The V200n provides accurate and reliable heading and position information at high update rates. To accomplish this task, the V200n uses a high performance GNSS receiver and two antennas for GNSS signal processing.

One antenna is designated as the primary GNSS antenna, and the other is the secondary GNSS antenna. Positions computed by the V200n are referenced to the phase center of the primary GNSS antenna. Heading data references the Vector formed from the primary GNSS antenna phase center to the secondary GNSS antenna phase center.

The heading arrow located on the bottom of the V200n enclosure defines system orientation. The arrow points in the direction the heading measurement is computed (when the antenna is installed parallel to the fore-aft line of the vessel). The secondary antenna is directly above the arrow.

---

## Differential Operation

---

### **Differential (DGSS) operation**

The V200n delivers positioning accuracies of 2.5 m 95% and provides positioning quality to better than 0.6 m 95% using differential corrections received through the internal SBAS demodulator or through Atlas L-band.

---

## SBAS Tracking

---

**SBAS tracking** The V200n features two-channel tracking that provides an enhanced ability to maintain a lock on an SBAS satellite when more than one satellite is in view. This redundant tracking approach results in more consistent tracking of an SBAS signal in areas where signal blockage of a satellite is possible.

---

## Atlas L-band

---

### **Atlas L-band**

Atlas L-band corrections are available worldwide. With Atlas, the positioning accuracy does not degrade as a function of distance to a base station, as the data content is not composed of a single base station's information, but an entire network's information.

The V200n can calculate a position with 30 cm RMS (horizontal) accuracy.

To configure the receiver to use Atlas L-band, a subscription must be purchased.

---

## Supplemental Sensors

---

### Overview

The V200n has an integrated supplemental sensor that is enabled by default. You can enable/disable the sensor.

The sensor acts to reduce the RTK search volume, which improves heading startup and reacquisition times. This improves the reliability and accuracy of selecting the correct heading solution by eliminating other possible erroneous solutions.

The [Hemisphere GNSS Technical Reference Manual](#) describes the commands and methodology required to recalibrate, query, or change the sensor status.

---

### Tilt aiding

The V200n's internal sensor is factory calibrated and enabled by default and constrains the RTK heading solution beyond the volume associated with a fixed antenna separation.

The V200n knows the approximate inclination of the secondary antenna with respect to the primary antenna. The search space defined by the sensor is reduced to a horizontal ring on the sphere's surface by reducing the search volume and decreases startup and reacquisition times (Figure 4-1).

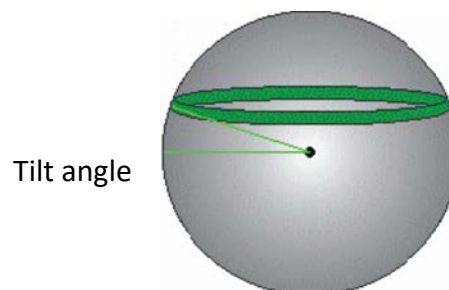

**Figure 4-1: V200n tilt aiding**

---

*Continued on next page*

## Supplemental Sensors, Continued

---

### Gyro aiding

The V200n's internal sensor reduces reacquisition times when a GNSS heading is lost due to blocked satellite signals.

The sensor provides a relative change in angle since the last computed heading and defines the search space as a wedge-shaped location (see Figure 4-2).

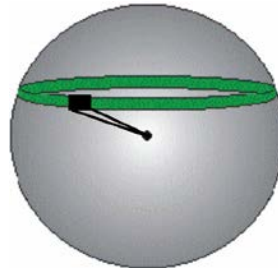

**Figure 4-2: V200n gyro aiding**

The gyro aiding accurately smooths the heading output and the ROT. The sensor also provides an alternate source of heading, accurate to within  $1^\circ$  per minute for up to three minutes in times of GNSS loss for either antenna. If the outage lasts longer than three minutes, the sensor will have drifted too far and the V200n begins outputting null fields in the heading output messages. There is no user control over the timeout period of the sensor.

The sensor initializes itself at power up and during initialization, or you can calibrate it as outlined in the [Hemisphere GNSS Technical Reference Manual](#).

For optimal performance, when the sensor is first initializing, the dynamics the sensor experiences during this warm-up period are similar to the regular operating dynamics.

---

*Continued on next page*



## Supplemental Sensors, Continued

---

**Gyro aiding,**  
continued

Gyro-aiding updates the post HTAU-smoothed heading. As a result, if the HTAU value is increased while gyro aiding is enabled, there will be little to no lag in heading output due to vessel maneuvers.

The [Hemisphere GNSS Technical Reference Manual](#) includes information on setting an appropriate HTAU value for the application.

---

## Time Constants

---

### Overview

The V200n incorporates user-configurable time constants that can provide a degree of smoothing to the heading, pitch, Rate-of-Turn (ROT), Course-over-Ground (COG), and speed measurements.

You can adjust these parameters depending on the expected dynamics of the vessel. For example, increasing the time is reasonable if the vessel is very large and is not able to turn quickly or would not pitch quickly. The resulting values would have reduced “noise,” resulting in consistent values with time.

If the vessel is quick and nimble, increasing this value can create a lag in measurements.

If you are unsure on how to set this value, it is best to be conservative and leave it at the default setting.

**Note:** For heading and rate of turn there is no lag once the sensor is calibrated and enabled.

Formulas for determining the level of smoothing are located in the [Hemisphere GNSS Technical Reference Manual](#). If you are unsure how to set this value, it is best to be conservative and leave the default setting.

---

### Heading

Use either MSGID 0x0028 (NMEA 2000) or the \$JATT,HTAU command (using the PocketMax Terminal window) to adjust the level of responsiveness of the true heading measurement. The default value of this constant is 0.1 seconds of smoothing when gyro-aid is enabled.

By disabling gyro-aid, the equivalent default value of the heading time constant should be 0.5 seconds of smoothing. This is not automatic, and therefore it must be manually entered.

**Note:** Increasing the time constant increases the level of heading smoothing and increases lag (with gyro-aid disabled).

---

*Continued on next page*

## Time Constants, Continued

---

### Pitch

Use either MSGID 0x003C (NMEA 2000) or the **\$JATT,PTAU** command (using the PocketMax Terminal window) to adjust the level of responsiveness of the pitch measurement. The default value of this constant is 0.5 seconds of smoothing.

**Note:** Increasing the time constant increases the level of pitch smoothing and increases lag.

---

### Rate-of-Turn (ROT)

Use either MSGID 0x0029 (NMEA 2000) or the **\$JATT,HRTAU** command (using the PocketMax Terminal window) to adjust the level of responsiveness of the ROT measurement. The default value of this constant is 2.0 seconds of smoothing.

**Note:** Increasing the time constant increases the level of ROT smoothing.

---

### Course-Over-Ground (COG)

Use either MSGID 0x002A (NMEA 2000) or the **\$JATT,COGTAU** command (using the PocketMax Terminal window) to adjust the level of responsiveness of the COG measurement. The default value of this constant is 0.0 seconds of smoothing.

**Note:** Increasing the time constant increases the level of COG smoothing.

COG is computed using only the primary GNSS antenna and its accuracy depends upon the speed of the vessel (noise is proportional to 1/speed). This value is invalid when the vessel is stationary, as tiny movements due to calculation inaccuracies are not representative of a vessel's movement.

---

### Speed

Use the **\$JATT,SPDTAU** command (using the PocketMax Terminal window) to adjust the level of responsiveness of the speed measurement provided. The default value of this parameter is 0.0 seconds of smoothing.

**Note:** Increasing the time constant increases the level of speed measurement smoothing.

## Appendix A: Troubleshooting

### Overview

---

#### Introduction

Appendix A provides troubleshooting for common problems.

---

#### Contents

	Topic	See Page
	Troubleshooting	69

---

## Troubleshooting

### Appendix A troubleshooting

Symptom	Possible Solution
Receiver fails to power	<ul style="list-style-type: none"> <li>• Verify polarity of power leads</li> <li>• Check integrity of power cable connectors</li> <li>• Check power input voltage (9 to 36 VDC)</li> <li>• Check the voltage coming out of the connector at the end of the cable</li> <li>• Check current restrictions imposed by power source (minimum available should be &gt; 1.0 A)</li> </ul>
No data from V200n	<ul style="list-style-type: none"> <li>• Check receiver power status to ensure the receiver is powered</li> <li>• Verify desired messages are activated using the <b>\$JSHOW</b> command (in the PocketMax Terminal window)</li> <li>• Check integrity and connectivity of cable connections</li> </ul>
No GNSS lock	<ul style="list-style-type: none"> <li>• Verify the V200n has a clear view of the sky</li> <li>• Use PocketMax to check how many satellites are in view and the SNR values</li> </ul>

*Continued on next page*

## Troubleshooting, Continued

### Appendix A troubleshooting , continued

Symptom	Possible Solution
No SBAS lock	<ul style="list-style-type: none"> <li>• Verify the V200n has a clear view of the sky</li> <li>• Set SBAS mode to automatic with the <b>\$JWAASPRN,AUTO</b> command</li> </ul> <div style="border: 1px solid black; padding: 5px; margin-top: 10px;"> <p><b>Note:</b> SBAS lock is only possible if you are in an appropriate SBAS region; currently, there is limited SBAS availability in the southern hemisphere.</p> </div>
No Atlas	<ul style="list-style-type: none"> <li>• First, check to see for an Atlas Basic subscription by sending <b>\$JK,SHOW</b> in the PocketMax Terminal window to see which commands are listed. Or connect to PocketMax, go to the About tab, and check the listed activations</li> <li>• Ensure you are tracking the correct Atlas satellite or set the receiver to 'Auto-Tune' by sending <b>\$JFREQ,AUTO</b> in the PocketMax Terminal window.</li> </ul>

*Continued on next page*

## Troubleshooting, Continued

### Appendix A troubleshooting , continued

Symptom	Possible Solution
No heading or incorrect heading value	<ul style="list-style-type: none"> <li>• Check CSEP value is constant without varying more than 1 cm (0.39 in)—larger variations may indicate a high multipath environment and require moving the receiver location</li> <li>• Heading is from primary GNSS antenna to secondary GNSS antenna, so the arrow on the underside of the V200n is directed to the bow side</li> <li>• Sending the <b>\$JATT,SEARCH</b> command (in the PocketMax Terminal window) forces the V200n to acquire a new heading solution (unless gyro is enabled)</li> <li>• Enable GYROAID to provide heading for up to three minutes during GNSS signal loss</li> <li>• Enable TILTAID to reduce heading search times</li> <li>• Monitor the number of satellites and SNR values for both antennas within PocketMax—at least four satellites should have strong SNR values</li> <li>• The volume of data requested for output by the V200n could be higher than the current baud rate supports.</li> </ul>

## Appendix B: Technical Specifications

---

**Introduction** Appendix B provides the V200n technical specifications, and the V200n certification information.

---

**Contents**

Topic	See Page
V200n Technical Specifications	73

---



## V200n Technical Specifications

V200n technical specifications

**Table B-1: V200n sensor and positioning accuracy**

Item	Specification
Receiver type	Vector sFreq GNSS Compass
Signals Received	GPS, GLONASS, BeiDou, Galileo, QZSS <sup>1</sup> , and Atlas
Channels	424
GPS sensitivity	-142 dBm
SBAS tracking	2-channel, parallel tracking
Update rate (position and heading)	10 Hz standard, 20 Hz optional
Positioning accuracy (Standard)	1.2 m RMS (Autonomous, no SA) <sup>1</sup> 0.30 m RMS (SBAS) <sup>2</sup>
Positioning accuracy (Optional)	0.50 m RMS (Atlas) <sup>3</sup>
Heading accuracy (Standard)	1.5° RMS <sup>1</sup>
Heading accuracy (Optional)	0.75° RMS <sup>1</sup>
Heave accuracy (GNSS)	30 cm <sup>4</sup>
Pitch/Roll accuracy	1.5° RMS
Rate of turn	90°/s maximum
Cold start	60 s typical (no almanac or RTC)
Warm start	20 s typical (almanac and RTC)
Hot start	1 s typical (almanac, RTC, and position)
Heading fix	10 s typical (valid position)
Maximum speed	1,850 kph (999 kts)
Maximum altitude	18,288m (60,000 ft)
Compass safe distance	50 cm <sup>5</sup>
Differential options	Atlas, SBAS

*Continued on next page*

## V200n Technical Specifications, Continued

---

V200n technical specifications, continued

**Table B-2: Communication**

<b>Item</b>	<b>Specification</b>
Connector ports	5-pin
Ports	NMEA 2000
Data I/O Protocol	NMEA 2000

**Table B-3: Power**

<b>Item</b>	<b>Specification</b>
Input voltage	6 to 36 VDC
<b>Power consumption</b>	(multi-GNSS, typical continuous draw @ 12V)
SBAS	3.2 W
Atlas	3.6 W
Power isolation	Isolated to enclosure
Reverse polarity protection	Yes

---

*Continued on next page*

## V200n Technical Specifications, Continued

V200n technical specifications, continued

**Table B-4: Mechanical**

Item	Specification
<b>Dimensions</b>	
No Mount:	34.8 L x 15.8 W x 6.5 H (cm)
LP Flat Mount:	34.8 L x 15.8 W x 7.6 H (cm)
HP Flat Mount:	34.8 L x 15.8 W x 10.7 H (cm)
Pole Mount:	34.8 L x 15.8 W x 16.8 H (cm)
<b>Notes:</b>	Tolerances for the above measurements are -0/+0.25 cm. Please refer to drawings in the <a href="#">Mounting the V200n</a> section of this document for details.
Weight (no mount)	0.75 kg
Power/data connector	5-pin
<b>Aiding Devices</b>	
Gyro:	Provides smooth heading, fast heading reacquisition and reliable 1° per minute heading for periods up to 3 minutes when loss of GPS has occurred <sup>2</sup>
Tilt Sensor:	Provides pitch and roll data and assist in fast start-up and reacquisition of heading solution

**Table B-5: Environmental**

Item	Specification
Operating temperature	-40°C to + 70°C (-22°F to + 158°F)
Storage temperature	-40°C to + 85°C (-40°F to + 185°F)
Humidity	95% non-condensing
Enclosure	ISO 60529:2013 for IPx6/IPx7/IPx9
Vibration	IEC 60945:2002 Section 8.7 Vibration
EMC	IEC60945:2002 EN 301 489-1 V2.1.1 EN 301 489-5 V2.1.1 EN 301 489-19 V2.1.0 EN 303 413 V1.1.1

*Continued on next page*

## V200n Technical Specifications, Continued

---

V200n technical specifications, continued

**Table B-6: Certifications**

Certification
NMEA 2000
RCM (Australia)

- 1 Depends on multipath environment, number of satellites in view, satellite geometry, no SA, and ionospheric activity
- 2 Depends on multipath environment, number of satellites in view, SBAS coverage and satellite geometry
- 3 Depends on multipath environment, number of satellites in view, and satellite geometry
- 4 Based on a 40 second time constant
- 5 This is the minimum safe distance measured when the product is placed in the vicinity of the steering magnetic compass. The ISO 694 defines "vicinity" relative to the compass as within 5 m (16.4 ft) separation

## Appendix C: Common Commands and Messages

### Overview

---

#### Contents

	Topic	See Page
	NMEA 2000 Messages	78
	NMEA 2000 Proprietary Messages	87
	Index	92

---

## NMEA 2000 Messages

V200n  
NMEA 2000  
received  
messages

Table C-1: NMEA 2000 messages received based on a request

PGN	Description	Default Update Rate (msec)	Freq (Hz)
059392	ISO Acknowledgement  Used to acknowledge the status of certain requests addressed to a specific ECU.	On Request	On Request
059904	ISO Request  Request the transmission of a specific PGN, addressed or broadcast.	On Request	On Request
060928	ISO Address Claim  Used to identify to other ECUs the address claimed by an ECU.	On Request	On Request
126996	Product Information  NMEA 2000 database version supported, manufacturer's product code, NMEA 2000 certification level, Load Equivalency number, and other product- specific information.	On Request	On Request
126464	Receive/Transmit PGNs group function  The Transmit / Receive PGN List Group type of function is defined by the first field.	On Request	On Request

*Continued on next page*

## NMEA 2000 Messages, Continued

V200n  
NMEA 2000  
received  
messages,  
continued

**Table C-1: NMEA 2000 messages received based on a request (continued)**

PGN	Description	Default Update Rate (msec)	Freq (Hz)
129545	<p>GNSS RAIM Output</p> <p>Used to provide the output from a GNSS receiver's Receiver Autonomous Integrity Monitoring (RAIM) process.</p> <p>The Integrity field value is based on the parameters set in PGN 129546 GNSS RAIM Settings.</p>	On Request	On Request
129546	<p>GNSS RAIM Settings</p> <p>Used to report the control parameters for a GNSS Receiver Autonomous Integrity Monitoring (RAIM) process.</p>	On Request	On Request

*Continued on next page*

## NMEA 2000 Messages, Continued

V200n  
NMEA 2000  
transmitted  
messages

Table C-2: NMEA 2000 transmitted messages

PGN	Description	Default Update Rate (msec)	Freq (Hz)
126992	System Time  The purpose of this PGN is twofold: 1) To provide a regular transmission of UTC time and date, and 2) To provide synchronism for measurement data	1000	1
126993	Heartbeat  Confirms a device is still present on the network.	60000	1/60
127250	Vessel Heading  Heading sensor value with a flag for True or Magnetic.  If the sensor value is Magnetic, the deviation field can be used to produce a Magnetic heading, and the variation field can be used to correct the Magnetic heading to produce a True heading.	100	10
127251	Rate of Turn  Rate of change of heading.	100	10

*Continued on next page*



## NMEA 2000 Messages, Continued

V200n  
NMEA 2000  
transmitted  
messages,  
continued

**Table C-2: NMEA 2000 transmitted messages (continued)**

PGN	Description	Default Update Rate (msec)	Freq (Hz)
127257	<p>Altitude</p> <p>Provides a single transmission that describes the position of a vessel relative to both horizontal and vertical planes.</p> <p>Altitude can be used for vessel stabilization, vessel control and onboard platform stabilization.</p>	1000	1
127258	<p>Magnetic Variation</p> <p>Message for transmitting variation.</p> <p>The message contains a sequence number to synchronize other messages such as Heading or Course over Ground.</p> <p>The quality of service and age of service are provided to determine appropriate level of service if multiple transmissions exist.</p>	1000	1

*Continued on next page*

## NMEA 2000 Messages, Continued

V200n  
NMEA 2000  
transmitted  
messages,  
continued

**Table C-2: NMEA 2000 transmitted messages (continued)**

PGN	Description	Default Update Rate (msec)	Freq (Hz)
129025	<p>Position, Rapid Update</p> <p>Provides latitude and longitude referenced to WGS84.</p> <p>A single frame message (opposed to other PGNs that include latitude and longitude and are defined as fast or multi- packet), this PGN lends itself to more frequent transmission without using excessive bandwidth.</p>	100	10
129026	<p>COG &amp; SOG, Rapid Update</p> <p>Single frame PGN that provides Course Over Ground (COG) and Speed Over Ground (SOG).</p>	250	4

*Continued on next page*

## NMEA 2000 Messages, Continued

V200n  
NMEA 2000  
transmitted  
messages,  
continued

**Table C-2: NMEA 2000 transmitted messages (continued)**

PGN	Description	Default Update Rate (msec)	Freq (Hz)
129027	<p>Position Delta, High Precision Rapid Update</p> <p>The 'Position Delta, High Precision Rapid Update' Parameter Group is for applications requiring high precision and very fast update rates for position data.</p> <p>This PGN provides delta position changes down to 1 mm with a delta time period accurate to 5 msec.</p>	100	10
129028	<p>Altitude Delta, High Precision Rapid Update</p> <p>The 'Altitude Delta, High Precision Rapid Update' Parameter Group is intended for applications requiring high precision and fast update rates are needed for altitude and course over ground data.</p> <p>This PGN can provide delta altitude changes down to 1 millimeter, a change in direction as small as 0.0057°, and with a delta time period accurate to 5 msec.</p>	100	10

*Continued on next page*

## NMEA 2000 Messages, Continued

V200n  
NMEA 2000  
transmitted  
messages,  
continued

**Table C-2: NMEA 2000 transmitted messages (continued)**

PGN	Description	Default Update Rate (msec)	Freq (Hz)
129029	GNSS Position Data  Conveys a comprehensive set of Global Navigation Satellite System (GNSS) parameters, including position information.	1000	1
129033	Time & Date  Single transmission that provides UTC time, UTC Date, and Local Offset.	1000	1
129539	GNSS DOPs  Provides a single transmission containing GNSS status and dilution of precision components (DOP) that indicate the contribution of satellite geometry to the overall positioning error.  Three DOP parameters are reported: horizontal (HDOP), Vertical (VDOP), and time (TDOP).	1000	1

*Continued on next page*

## NMEA 2000 Messages, Continued

V200n  
NMEA 2000  
transmitted  
messages,  
continued

**Table C-2: NMEA 2000 transmitted messages (continued)**

PGN	Description	Default Update Rate (msec)	Freq (Hz)
129540	GNSS Sats in View  GNSS information on current satellites in view tagged by sequence ID.  Information includes PRN, elevation, azimuth, SNR, defines the number of satellites; defines the satellite number and the information.	1000	1
126993	Heartbeat  Periodically announces presence on the CAN bus.	60000	0.016667

*Continued on next page*

## NMEA 2000 Messages, Continued

V200n  
NMEA 2000  
transmitted  
messages,  
continued

**Table C-2: NMEA 2000 transmitted messages (continued)**

PGN	Description	Default Update Rate (msec)	Freq (Hz)
129033	<p>Local Time Offset</p> <p>Indicates offset between a configured local time and UTC. As of currently we do not support a local time, so this always reports no offset.</p>	On Request	On Request
126998	<p>Configuration Information</p> <p>Used for returning fields describing an installation. Currently always returns blank.</p>	On Request	On Request

## NMEA 2000 Proprietary Messages

---

### **NMEA 2000 Proprietary Messages**

For NMEA 2000 proprietary messages via CAN for tasks such as receiver configuration, please refer to the Hemisphere GNSS website/Resources & Support/Technical Documentation/[NMEA Proprietary Messages Reference Manual](#).

---

*Continued on next page*

## NMEA 2000 Proprietary Messages, Continued

### NMEA 2000 proprietary messages

The following lists NMEA 2000 proprietary messages.

**Table C-3: NMEA 2000 proprietary messages**

<b>NMEA 2000 proprietary messages</b>
<b>Single Frame packet definition - PGN: EFX (Destination addressable)</b>
MSGID 0x0001 - N2K,MCODE
MSGID 0x0002 - N2K,PCODE
MSGID 0x0003 - N2K,LOAD
MSGID 0x0004 - N2K,CERT
MSGID 0x0005 - JVERSION
MSGID 0x0006 - N2K,RESET
MSGID 0x0007 - N2K,ADDRESS
MSGID 0x0008 - JDIFF
MSGID 0x0009 - JDIFF,INCLUDE
MSGID 0x000A - JMODES
MSGID 0x000B - JSBASPRN
MSGID 0x000C - JBAUD,PORTx
MSGID 0x000D - JMASK
MSGID 0x000E - JATT,TILTAID
MSGID 0x000F - JATT,TILTCAL
MSGID 0x0010 - JATT,HBIAS
MSGID 0x0011 - JATT,PBIAS
MSGID 0x0012 - JATT,GYROAID
MSGID 0x0013 - JRESET
MSGID 0x0014 - JI, serial number
MSGID 0x0015 - JRAIM
MSGID 0x0016 - JATT,HIGHMP
MSGID 0x0017 - JAPP
MSGID 0x0018 - JAGE
MSGID 0x0019 - BIN1, stdev residuals
MSGID 0x001A - RD1
MSGID 0x001B - JK (read)
MSGID 0x001D - JWCONF,12

*Continued on next page*



## NMEA 2000 Proprietary Messages, Continued

NMEA 2000  
proprietary  
messages,  
continued

**Table C-3: NMEA proprietary messages (continued)**

<b>NMEA 2000 proprietary message</b>
<b>Single Frame packet definition - PGN: EFXX (Destination addressable)</b>
MSGID 0x001F - JI, application version
MSGID 0x0020 - JSYSVER
MSGID 0x0021 - JT
MSGID 0x0022 - JATT,MSEP
MSGID 0x0023 - JATT,CSEP
MSGID 0x0025 – NMEA 2000 Message Control
MSGID 0x0026 - JNP
MSGID 0x0027 - JSMOOTH
MSGID 0x0028 - JATT,HTAU
MSGID 0x0029 - JATT,HRTAU
MSGID 0x002A - JATT,COGTAU
MSGID 0x002C - JATT,NEGILT
MSGID 0x002E - JATT,LEVEL
MSGID 0x002F - JATT,MOVEBAS
MSGID 0x0031 - GPHEV Heave
MSGID 0x0032 - JSAVE
MSGID 0x0034 - INTLT Raw Tilt Values
MSGID 0x0037 - Distance to Base
MSGID 0x0038 - JFREQ
MSGID 0x0039 - JLIMIT
MSGID 0x003A - JAIR
MSGID 0x003B - JATT,EXACT
MSGID 0x003C - JATT,PTAU
MSGID 0x003D - JATT,ROLL
MSGID 0x003E - JPOS
MSGID 0x003F - Serial Messages
MSGID 0x0040 - HPR StdDev
MSGID 0x0045 - JGEO

*Continued on next page*

## NMEA 2000 Proprietary Messages, Continued

---

NMEA 2000  
proprietary  
messages,  
continued

**Table C-3: NMEA proprietary messages (continued)**

<b>NMEA 2000 proprietary message</b>
<b>Multi-Frame Fast-Packet definition – PGN: 1EFFF (Destination addressable)</b>
MSGID 0x8001 - N2K,VERSION
MSGID 0x8003 - JPOSOFFSET
MSGID 0x8004 - JVERSION
MSGID 0x8005 - JAUTH
MSGID 0x8008 - Generic GNSS Serial Command
MSGID 0x8009 - RAW data transfer for differential
MSGID 0x800A - JI, Extended info
MSGID 0x800B - N2K,MODEL
MSGID 0x800D - RTKSTAT
MSGID 0x800E - ATTSTAT

## Index

Activation .....	6	<b>HPR values</b> .....	27
Atlas .....	6, 58, 62	NMEA .....	7, 78
beacon.....	60	Pitch .....	67, 73
BeiDou.....	6	radar mounting plate .....	35
cable length.....	23	Rate-of-Turn.....	66
course-over-ground .....	66	Rate-of-Turn (ROT).....	66, 67
Course-Over-Ground (COG) .....	67	RTK .....	7, 58, 63, 65, 73
CSEP value .....	71	SBAS .....	7, 10, 58, 60, 61, 70, 73
DGPS/DGNSS.....	6	Speed .....	67, 82
Differential Corrections .....	6	Subscription .....	6, 7
environmental.....	23, 25	Tilt aiding.....	63
firmware.....	18	tilt sensors.....	9, 63
GLONASS .....	6	TILTAID .....	71
GPS .....	6, 7	VHF interference.....	24
gyro .....	64, 66, 71	VHF marine radio .....	24
Heading .....	80, 81	WiFi Connection.....	44

# End User License Agreement

---

## End User license agreement

**IMPORTANT** - This is an agreement (the "**Agreement**") between you, the end purchaser ("**Licensee**") and Hemisphere GNSS Inc. ("**Hemisphere**") which permits Licensee to use the Hemisphere software (the "**Software**") that accompanies this Agreement. This Software may be licensed on a standalone basis or may be embedded in a Product. Please read and ensure that you understand this Agreement before installing or using the Software Update or using a Product.

In this agreement any product that has Software embedded in it at the time of sale to the Licensee shall be referred to as a "**Product**". As well, in this Agreement, the use of a Product shall be deemed to be use of the Software which is embedded in the Product.

BY INSTALLING OR USING THE SOFTWARE UPDATE OR THE PRODUCT, LICENSEE THEREBY AGREES TO BE LEGALLY BOUND BY THE TERMS OF THIS AGREEMENT. IF YOU DO NOT AGREE TO THESE TERMS, (I) DO NOT INSTALL OR USE THE SOFTWARE, AND (II) IF YOU ARE INSTALLING AN UPDATE TO THE SOFTWARE, DO NOT INSTALL THE UPDATE AND PROMPTLY DESTROY IT.

HEMISPHERE PROVIDES LIMITED WARRANTIES IN RELATION TO THE SOFTWARE. AS WELL, THOSE WHO USE THE EMBEDDED SOFTWARE DO SO AT THEIR OWN RISK. YOU SHOULD UNDERSTAND THE IMPORTANCE OF THESE AND OTHER LIMITATIONS SET OUT IN THIS AGREEMENT BEFORE INSTALLING OR USING THE SOFTWARE OR THE PRODUCT.

1. **LICENSE.** Hemisphere hereby grants to Licensee a non-transferable and non-exclusive license to use the Software as embedded in a Product and all Updates (collectively the "**Software**"), solely in binary executable form.
2. **RESTRICTIONS ON USE.** Licensee agrees that Licensee and its employees will not directly or indirectly, in any manner whatsoever:
  - a. install or use more copies of the Software than the number of copies that have been licensed;
  - b. use or install the Software in connection with any product other than the Product the Software was intended to be used or installed on as set out in the documentation that accompanies the Software.
  - c. copy any of the Software or any written materials for any purpose except as part of Licensee's normal backup processes;
  - d. modify or create derivative works based on the Software;
  - e. sub-license, rent, lease, loan or distribute the Software;
  - f. permit any third party to use the Software;
  - g. use or operate Product for the benefit of any third party in any type of service outsourcing, application service, provider service or service bureau capacity;
  - h. reverse engineer, decompile or disassemble the Software or otherwise reduce it to a human perceivable form;
  - i. Assign this Agreement or sell or otherwise transfer the Software to any other party except as part of the sale or transfer of the whole Product.
3. **UPDATES.** At Hemisphere's discretion Hemisphere may make Updates available to Licensee. An update ("**Update**") means any update to the Software that is made available to Licensee including error corrections, enhancements and other modifications. Licensee may access, download and install Updates during the Warranty Period only. All Updates that Licensee downloads, installs or uses shall be deemed to be Software and subject to this Agreement. Hemisphere reserves the right to modify the Product without any obligation to notify, supply or install any improvements or alterations to existing Software.
4. **SUPPORT.** Hemisphere may make available directly or through its authorized dealers telephone and email support for the Software. Contact Hemisphere to find the authorized dealer near you. As well, Hemisphere may make available user and technical documentation regarding the Software. Hemisphere reserves the right to reduce and limit access to such support at any time.

---

*Continued on next page*

## End User License Agreement, Continued

---

### End User license agreement, continued

5. **BACKUPS AND RECOVERY.** Licensee shall back-up all data used, created or stored by the Software on a regular basis as necessary to enable proper recovery of the data and related systems and processes in the event of a malfunction in the Software or any loss or corruption of data caused by the Software. Licensee shall assume all risks of loss or damage for any failure to comply with the foregoing.
6. **OWNERSHIP.** Hemisphere and its suppliers own all rights, title and interest in and to the Software and related materials, including all intellectual property rights. The Software is licensed to Licensee, not sold.
7. **TRADEMARKS.** Hemisphere GNSS<sup>®</sup>, the Hemisphere GNSS logo, TRACER<sup>™</sup>, Crescent<sup>®</sup>, Eclipse<sup>™</sup>, e-Dif<sup>®</sup>, L-Dif<sup>™</sup>, PocketMax<sup>™</sup>, S320<sup>™</sup>, SBX-4<sup>™</sup>, Vector<sup>™</sup>, Vega<sup>™</sup>, Phantom<sup>™</sup> XF1<sup>™</sup>, XF2<sup>™</sup>, Cygnus<sup>™</sup>, Atlas<sup>™</sup> aRTK, SureFix<sup>™</sup>, Athena<sup>™</sup>, Aquila<sup>™</sup>, Lyra<sup>™</sup>, Outback Guidance<sup>™</sup>, and EDRIVE<sup>™</sup> are proprietary trademarks of Hemisphere GNSS, Inc. Other trademarks are the properties of their respective owners. and the associated logos are trademarks of Hemisphere. Other trademarks are the property of their respective owners. Licensee may not use any of these trademarks without the consent of their respective owners.
8. **LIMITED WARRANTY.** Hemisphere warrants solely to the Licensee, subject to the exclusions and procedures set forth herein below, that for a period of one (1) year from the original date of purchase of the Product in which it is embedded (the "Warranty Period"), the Software, under normal use and maintenance, will conform in all material respects to the documentation provided with the Software and any media will be free of defects in materials and workmanship. For any Update, Hemisphere warrants, for 90 days from performance or delivery, or for the balance of the original Warranty Period, whichever is greater, that the Update, under normal use and maintenance, will conform in all material respects to the documentation provided with the Update and any media will be free of defects in materials and workmanship. Notwithstanding the foregoing, Hemisphere does not warrant that the Software will meet Licensee's requirements or that its operation will be error free.
9. **WARRANTY EXCLUSIONS.** The warranty set forth in Section (8) will not apply to any deficiencies caused by (a) the Product not being used as described in the documentation supplied to Licensee, (b) the Software having been altered, modified or converted in any way by anyone other than Hemisphere approved by Hemisphere, (c) any malfunction of Licensee's equipment or other software, or (d) damage occurring in transit or due to any accident, abuse, misuse, improper installation, lightning (or other electrical discharge) or neglect other than that caused by Hemisphere. Hemisphere GNSS does not warrant or guarantee the precision or accuracy of positions obtained when using the Software (whether standalone or embedded in a Product). The Product and the Software is not intended and should not be used as the primary means of navigation or for use in safety of life applications. The potential positioning and navigation accuracy obtainable with the Software as stated in the Product or Software documentation serves to provide only an estimate of achievable accuracy based on specifications provided by the US Department of Defense for GPS positioning and DGPS service provider performance specifications, where applicable.
10. **WARRANTY DISCLAIMER.** EXCEPT AS EXPRESSLY SET OUT IN THIS AGREEMENT, HEMISPHERE MAKES NO REPRESENTATION, WARRANTY OR CONDITION OF ANY KIND TO LICENSEE, WHETHER VERBAL OR WRITTEN AND HEREBY DISCLAIMS ALL REPRESENTATIONS, WARRANTIES AND CONDITIONS OF ANY KIND INCLUDING FITNESS FOR A PARTICULAR PURPOSE, MERCHANTABILITY, ACCURACY, RELIABILITY OR THAT THE USE OF THE SOFTWARE WILL BE UNINTERRUPTED OR ERROR-FREE AND HEREBY DISCLAIMS ALL REPRESENTATIONS, WARRANTIES AND CONDITIONS ARISING AS A RESULT OF CUSTOM, USAGE OR TRADE AND THOSE ARISING UNDER STATUTE.
11. **LIMITS ON WARRANTY DISCLAIMER.** Some jurisdictions do not allow the exclusion of implied warranties or conditions, so some of the above exclusions may not apply to Licensee. In that case, any implied warranties or conditions which would then otherwise arise will be limited in duration to ninety (90) days from the date of the license of the Software or the purchase of the Product. The warranties given herein give Licensee specific legal rights and Licensee may have other rights which may vary from jurisdiction to jurisdiction.

---

*Continued on next page*

## End User License Agreement, Continued

---

### End User license agreement, continued

12. **CHANGE TO WARRANTY.** No employee or agent of Hemisphere is authorized to change the warranty provided or the limitation or disclaimer of warranty provisions. All such changes will only be effective if pursuant to a separate agreement signed by senior officers of the respective parties.
13. **WARRANTY CLAIM.** In the event Licensee has a warranty claim Licensee must first check for and install all Updates that are made available. The warranty will not otherwise be honored. Proof of purchase may be required. Hemisphere does not honor claims asserted after the end of the Warranty Period.
14. **LICENSEE REMEDIES.** In all cases which involve a failure of the Software to conform in any material respect to the documentation during the Warranty Period or a breach of a warranty, Hemisphere's sole obligation and liability, and Licensee's sole and exclusive remedy, is for Hemisphere, at Hemisphere's option, to (a) repair the Software, (b) replace the Software with software conforming to the documentation, or (c) if Hemisphere is unable, on a reasonable commercial basis, to repair the Software or to replace the Software with conforming software within ninety (90) days, to terminate this Agreement and thereafter Licensee shall cease using the Software. Hemisphere will also issue a refund for the price paid by Licensee less an amount on account of amortization, calculated on a straight-line basis over a deemed useful life of three (3) years.
15. **LIMITATION OF LIABILITY.** IN NO EVENT WILL HEMISPHERE BE LIABLE TO LICENSEE FOR ANY INCIDENTAL, CONSEQUENTIAL, SPECIAL OR INDIRECT DAMAGES INCLUDING ARISING IN RELATION TO ANY LOSS OF DATA, INCOME, REVENUE, GOODWILL OR ANTICIPATED SAVINGS EVEN IF HEMISPHERE HAS BEEN INFORMED OF THE POSSIBILITY OF SUCH LOSS OR DAMAGE. FURTHER, IN NO EVENT WILL HEMISPHERE'S TOTAL CUMULATIVE LIABILITY HEREUNDER, FROM ALL CAUSES OF ACTION OF ANY KIND, EXCEED THE TOTAL AMOUNT PAID BY LICENSEE TO HEMISPHERE TO PURCHASE THE PRODUCT. THIS LIMITATION AND EXCLUSION APPLIES IRRESPECTIVE OF THE CAUSE OF ACTION, INCLUDING BUT NOT LIMITED TO BREACH OF CONTRACT, NEGLIGENCE, STRICT LIABILITY, TORT, BREACH OF WARRANTY, MISREPRESENTATION OR ANY OTHER LEGAL THEORY AND WILL SURVIVE A FUNDAMENTAL BREACH.
16. **LIMITS ON LIMITATION OF LIABILITY.** Some jurisdictions do not allow for the limitation or exclusion of liability for incidental or consequential damages, so the above limitation or exclusion may not apply to Licensee and Licensee may also have other legal rights which may vary from jurisdiction to jurisdiction.
17. **BASIS OF BARGAIN.** Licensee agrees and acknowledges that Hemisphere has set its prices and the parties have entered into this Agreement in reliance on the limited warranties, warranty disclaimers and limitations of liability set forth herein, that the same reflect an agreed-to allocation of risk between the parties (including the risk that a remedy may fail of its essential purpose and cause consequential loss), and that the same forms an essential basis of the bargain between the parties. Licensee agrees and acknowledges that Hemisphere would not have been able to sell the Product at the amount charged on an economic basis without such limitations.
18. **PROPRIETARY RIGHTS INDEMNITY.** Hemisphere shall indemnify, defend and hold harmless Licensee from and against any and all actions, claims, demands, proceedings, liabilities, direct damages, judgments, settlements, fines, penalties, costs and expenses, including royalties and attorneys' fees and related costs, in connection with or arising out of any actual infringement of any third party patent, copyright or other intellectual property right by the Software or by its use, in accordance with this Agreement and documentation, PROVIDED THAT: (a) Hemisphere has the right to assume full control over any action, claim, demand or proceeding, (b) Licensee shall promptly notify Hemisphere of any such action, claim, demand, or proceeding, and (c) Licensee shall give Hemisphere such reasonable assistance and tangible material as is reasonably available to Licensee for the defense of the action, claim, demand or proceeding. Licensee shall not settle or compromise any of same for which Hemisphere has agreed to assume responsibility without Hemisphere's prior written consent. Licensee may, at its sole cost and expense, retain separate counsel from the counsel utilized or retained by Hemisphere. 19. **INFRINGEMENT.** If use of the Software may be enjoined due to a claim of infringement by a third party then, at its sole discretion and expense, Hemisphere may do one of the following: (a)

---

*Continued on next page*

## End User License Agreement, Continued

---

### End User license agreement, continued

19. negotiate a license or other agreement so that the Product is no longer subject to such a potential claim, (b) modify the Product so that it becomes non-infringing, provided such modification can be accomplished without materially affecting the performance and functionality of the Product, (c) replace the Software, or the Product, with non-infringing software, or product, of equal or better performance and quality, or (d) if none of the foregoing can be done on a commercially reasonable basis, terminate this license and Licensee shall stop using the Product and Hemisphere shall refund the price paid by Licensee less an amount on account of amortization, calculated on a straight-line basis over a deemed useful life of three (3) years.
20. The foregoing sets out the entire liability of Hemisphere and the sole obligations of Hemisphere to Licensee in respect of any claim that the Software or its use infringes any third party rights.
21. **INDEMNIFICATION.** Except in relation to an infringement action, Licensee shall indemnify and hold Hemisphere harmless from any and all claims, damages, losses, liabilities, costs and expenses (including reasonable fees of lawyers and other professionals) arising out of or in connection with Licensee's use of the Product, whether direct or indirect, including without limiting the foregoing, loss of data, loss of profit or business interruption. **TERMINATION.** Licensee may terminate this Agreement at any time without cause. Hemisphere may terminate this Agreement on 30 days notice to Licensee if Licensee fails to materially comply with each provision of this Agreement unless such default is cured within the 30 days. Any such termination by a party shall be in addition to and without prejudice to such rights and remedies as may be available, including injunction and other equitable remedies. Upon receipt by Licensee of written notice of termination from Hemisphere or termination by Licensee, Licensee shall at the end of any notice period (a) cease using the Software; and (b) return to Hemisphere (or destroy and provide a certificate of a Senior Officer attesting to such destruction) the Software and all related material and any magnetic or optical media provided to Licensee. The provisions of Sections 6), 7), 8), 9), 10), 15), 21), 26) and 27) herein shall survive the expiration or termination of this Agreement for any reason.
22. **EXPORT RESTRICTIONS.** Licensee agrees that Licensee will comply with all export control legislation of Canada, the United States, Australia and any other applicable country's laws and regulations, whether under the Arms Export Control Act, the International Traffic in Arms Regulations, the Export Administration Regulations, the regulations of the United States Departments of Commerce, State, and Treasury, or otherwise as well as the export control legislation of all other countries.
23. **PRODUCT COMPONENTS.** The Product may contain third party components. Those third party components may be subject to additional terms and conditions. Licensee is required to agree to those terms and conditions in order to use the Product.
24. **FORCE MAJEURE EVENT.** Neither party will have the right to claim damages as a result of the other's inability to perform or any delay in performance due to unforeseeable circumstances beyond its reasonable control, such as labor disputes, strikes, lockouts, war, riot, insurrection, epidemic, Internet virus attack, Internet failure, supplier failure, act of God, or governmental action not the fault of the non-performing party.
25. **FORUM FOR DISPUTES.** The parties agree that the courts located in Calgary, Alberta, Canada and the courts of appeal there from will have exclusive jurisdiction to resolve any disputes between Licensee and Hemisphere concerning this Agreement or Licensee's use or inability to use the Software and the parties hereby irrevocably agree to attorn to the jurisdiction of those courts. Notwithstanding the foregoing, either party may apply to any court of competent jurisdiction for injunctive relief.
26. **APPLICABLE LAW.** This Agreement shall be governed by the laws of the Province of Alberta, Canada, exclusive of any of its choice of law and conflicts of law jurisprudence.
27. **CISG.** The United Nations Convention on Contracts for the International Sale of Goods will not apply to this Agreement or any transaction hereunder.

**GENERAL.** This is the entire agreement between Licensee and Hemisphere relating to the Product and Licensee's use of the same, and supersedes all prior, collateral or contemporaneous oral or written representations, warranties or agreements regarding the same. No amendment to or modification of this Agreement will be binding unless in writing and signed by duly authorized representatives of the parties. Any and all terms and conditions set out in any correspondence between the parties or set out in a purchase order which are different from or in addition to the terms and conditions set forth herein, shall have no application and no written notice of same shall be required. In the event that one or more of the provisions of this Agreement is found to be illegal or unenforceable, this Agreement shall not be rendered inoperative but the remaining provisions shall continue in full force and effect.

## Warranty Notice

---

### Warranty notice

**COVERED PRODUCTS:** This warranty covers all products manufactured by Hemisphere GNSS and purchased by the end purchaser (the "Products"), unless otherwise specifically and expressly agreed in writing by Hemisphere GNSS.

**LIMITED WARRANTY:** Hemisphere GNSS warrants solely to the end purchaser of the Products, subject to the exclusions and procedures set forth below, that the Products sold to such end purchaser and its internal components shall be free, under normal use and maintenance, from defects in materials, and workmanship and will substantially conform to Hemisphere GNSS's applicable specifications for the Product, for a period of 12 months from delivery of such Product to such end purchaser (the "Warranty Period"). Repairs and replacement components for the Products are warranted, subject to the exclusions and procedures set forth below, to be free, under normal use and maintenance, from defects in material and workmanship, and will substantially conform to Hemisphere GNSS's applicable specifications for the Product, for 90 days from performance or delivery, or for the balance of the original Warranty Period, whichever is greater.

**EXCLUSION OF ALL OTHER WARRANTIES.** The LIMITED WARRANTY shall apply only if the Product is properly and correctly installed, configured, interfaced, maintained, stored, and operated in accordance with Hemisphere GNSS relevant User's Manual and Specifications, AND the Product is not modified or misused. The Product is provided "AS IS" and the implied warranties of MERCHANTABILITY and FITNESS FOR A PARTICULAR PURPOSE and ALL OTHER WARRANTIES,

express, implied or arising by statute, by course of dealing or by trade usage, in connection with the design, sale, installation, service or use of any products or any component thereof, are EXCLUDED from this transaction and shall not apply to the Product. The LIMITED WARRANTY is IN LIEU OF any other warranty, express or implied, including but not limited to, any warranty of MERCHANTABILITY or FITNESS FOR A PARTICULAR PURPOSE, title, and non-infringement.

**LIMITATION OF REMEDIES.** The purchaser's EXCLUSIVE REMEDY against Hemisphere GNSS shall be, at Hemisphere GNSS's option, the repair or replacement of any defective Product or components thereof. The purchaser shall notify Hemisphere GNSS or a Hemisphere GNSS's approved service center immediately of any defect. Repairs shall be made through a Hemisphere GNSS approved service center only. Repair, modification or service of Hemisphere GNSS products by any party other than a Hemisphere GNSS approved service center shall render this warranty null and void. The remedy in this paragraph shall only be applied in the event that the Product is properly and correctly installed, configured, interfaced, maintained, stored, and operated in accordance with Hemisphere GNSS's relevant User's Manual and Specifications, AND the Product is not modified or misused. NO OTHER REMEDY (INCLUDING, BUT NOT LIMITED TO, SPECIAL, INDIRECT, INCIDENTAL, CONSEQUENTIAL OR CONTINGENT DAMAGES FOR LOST PROFITS, LOST SALES, INJURY TO PERSON OR PROPERTY, OR ANY OTHER INCIDENTAL OR CONSEQUENTIAL LOSS) SHALL BE AVAILABLE

TO PURCHASER, even if Hemisphere GNSS has been advised of the possibility of such damages. Without limiting the foregoing, Hemisphere GNSS shall not be liable for any damages of any kind resulting from installation, use, quality, performance or accuracy of any Product.

**HEMISPHERE IS NOT RESPONSIBLE FOR PURCHASER'S NEGLIGENCE OR UNAUTHORIZED USES OF THE PRODUCT.**

IN NO EVENT SHALL Hemisphere GNSS BE IN ANY WAY RESPONSIBLE FOR ANY DAMAGES RESULTING FROM PURCHASER'S OWN NEGLIGENCE, OR FROM OPERATION OF THE PRODUCT IN ANY WAY OTHER THAN AS SPECIFIED IN Hemisphere GNSS's RELEVANT USER'S MANUAL AND SPECIFICATIONS. Hemisphere GNSS is NOT RESPONSIBLE for defects or performance problems resulting from (1) misuse, abuse, improper installation, neglect of Product; (2) the utilization of the Product with hardware or software products, information, data, systems, interfaces or devices not made, supplied or specified by Hemisphere GNSS; (3) the operation of the Product under any specification other than, or in addition to, the specifications set forth in Hemisphere GNSS's relevant User's Manual and Specifications; (4) damage caused by accident or natural events, such as lightning (or other electrical discharge) or fresh/ salt water immersion of Product; (5) damage occurring in transit; (6) normal wear and tear; or (7) the operation or failure of operation of any satellite-based positioning system or differential correction service; or the availability or performance of any satellite-based positioning signal or differential correction signal.

**THE PURCHASER IS RESPONSIBLE FOR OPERATING THE VEHICLE SAFELY.** The purchaser is solely responsible for the safe operation of the vehicle used in connection with the Product, and for maintaining proper system control settings. UNSAFE DRIVING OR SYSTEM CONTROL SETTINGS CAN RESULT IN PROPERTY DAMAGE, INJURY, OR DEATH.

---

*Continued on next page*



## Warranty Notice, Continued

---

### Warranty notice, continued

The purchaser is solely responsible for his/her safety and for the safety of others. The purchaser is solely responsible for maintaining control of the automated steering system at all times. THE PURCHASER IS SOLELY RESPONSIBLE FOR ENSURING THE PRODUCT IS PROPERLY AND CORRECTLY INSTALLED, CONFIGURED, INTERFACED, MAINTAINED, STORED, AND OPERATED IN ACCORDANCE WITH Hemisphere GNSS's RELEVANT USER'S MANUAL AND SPECIFICATIONS. Hemisphere GNSS does not warrant or guarantee the positioning and navigation precision or accuracy obtained when using Products. Products are not intended for primary navigation or for use in safety of life applications. The potential accuracy of Products as stated in Hemisphere GNSS literature and/or Product specifications serves to provide only an estimate of achievable accuracy based on performance specifications provided by the satellite service operator (i.e. US Department of Defense in the case of GPS and differential correction service provider. Hemisphere GNSS reserves the right to modify Products without any obligation to notify, supply or install any improvements or alterations to existing Products.

**GOVERNING LAW.** This agreement and any disputes relating to, concerning or based upon the Product shall be governed by and interpreted in accordance with the laws of the State of Arizona.

**OBTAINING WARRANTY SERVICE.** In order to obtain warranty service, the end purchaser must bring the Product to a Hemisphere GNSS approved service center along with the end purchaser's proof of purchase. Hemisphere GNSS does not warrant claims asserted after the end of the warranty period. For any questions regarding warranty service or to obtain information regarding the location of any of Hemisphere GNSS approved service center, contact Hemisphere GNSS at the following address:

**Hemisphere GNSS**

8515 E. Anderson Drive Scottsdale, AZ 85255, USA

Phone: +1-480-348-6380

Fax: +1-480-270-5070

[TECHSUPPORT@HGSS.COM](mailto:TECHSUPPORT@HGSS.COM)

[WWW.HGSS.COM](http://WWW.HGSS.COM)

---



Hemisphere GNSS Inc.  
8515 East Anderson Drive  
Scottsdale, Arizona, US 85255  
Phone: 480-348-6380  
Fax: 480-270-5070  
[PRECISION@HGNSS.COM](mailto:PRECISION@HGNSS.COM)  
[WWW.HGNSS.COM](http://WWW.HGNSS.COM)