



## INSTALLATION MANUAL

# High-efficiency 4kW Genverter for marine use



Art.no: 40200831

WHISPERPOWER BV  
Kelvinlaan 82  
9207 JB Drachten  
Netherlands  
Tel.: +31-512-571550  
Fax.: +31-512-571599  
[www.whisperpower.com](http://www.whisperpower.com)

V1.1 May 2017



## CONTENTS

<b>1</b>	<b>INTRODUCTION .....</b>	<b>3</b>
1.1	Use of this manual.....	3
1.2	Validity of this manual.....	3
1.3	Installation parts.....	3
1.4	CHP: Combined Heat and Power generation.....	3
<b>2</b>	<b>INSTALLATION .....</b>	<b>4</b>
2.1	General.....	4
2.2	Location.....	4
2.3	Protection against dirt, water, high temperature and weather conditions.....	4
2.4	Instructions for optimal sound and vibration insulation .....	4
2.5	Ventilation .....	5
2.5.1	General .....	5
2.6	Connections.....	5
2.6.1	Overview.....	5
2.7	Fuel supply.....	5
2.7.1	Fuel tank .....	5
2.7.2	Fuel lift pump.....	5
2.7.3	Fuel pipes.....	7
2.7.4	Fuel filters .....	7
2.8	Cooling.....	8
2.8.1	General .....	8
2.8.2	Inter-cooling .....	8
2.8.3	Raw water supply.....	8
2.8.4	Installation of through hull fitting.....	9
2.8.5	Water strainer.....	9
2.8.6	Siphon breaker (air vent) .....	9
2.9	Exhaust system .....	9
2.9.1	Standard wet exhaust system installation .....	10
2.9.2	"Super silent" exhaust system .....	10
2.10	Dry exhaust system .....	12
2.10.1	General remarks .....	12
<b>3</b>	<b>ELECTRICAL INSTALLATION (12 VOLT) .....</b>	<b>14</b>
3.1	Engine control system .....	14
3.2	Starter battery.....	14
3.3	Other recommendations and warnings.....	14
3.4	AC power system (230 Volt) .....	14
3.5	Cable protection (fuses) .....	14
3.6	Grounding.....	15
3.7	Cable.....	15
3.8	Transfer switch .....	15
<b>4</b>	<b>INSTALLATION SPECIFICATIONS .....</b>	<b>16</b>
4.1	General .....	16
4.2	Commissioning table .....	16
4.3	Technical data .....	16
4.4	Specification of the accessories.....	17
4.5	Installation materials.....	17
<b>5</b>	<b>DIAGRAMS &amp; DRAWINGS .....</b>	<b>21</b>
5.1	Electrical diagrams.....	21
5.2	Mechanical drawings.....	23

# 1 INTRODUCTION

## 1.1 USE OF THIS MANUAL

This manual serves as a guideline for the safe and effective installation of the WhisperPower GV4 Piccolo Genverters for marine applications.

It is obligatory that every person who is involved with the installation of the Genverter must be completely familiar with the contents of this manual, and that he/she carefully follows the instructions contained herein.

To ensure reliability and durability of the equipment, it is very important that the installation is carried out with the utmost care and attention. To avoid problems, such as temperature problems, noise levels, vibration, etc. the instructions set out in this manual must be followed and all installation work must be carried out only by qualified, authorized and trained personnel, consistent with the locally applicable standards and taking into consideration the safety guidelines and measures (Chapter 2 of the user's manual).

The information, specifications, illustrations and statements contained within this publication are given with our best intentions and are believed to be correct at the time of going to press.

Our policy is one of continued development and we reserve the right to amend any technical information without prior notice.

Whilst every effort is made to ensure the accuracy of the particulars contained within this publication neither the manufacturer, distributor, or dealer in any circumstances shall be held liable for any inaccuracy or the consequences thereof.

Keep this manual in a secure place!

## 1.2 VALIDITY OF THIS MANUAL

All of the specifications, provisions and instructions contained in this manual apply solely to standard versions of the two and three cylinder Genverters delivered by WhisperPower.

This manual is valid for the following models:

Part number	Description
49002005	M-GV4 Piccolo MARINE

Refer to the user's manual for identification of the Genverter set. For other models see our website: [www.whisperpower.com](http://www.whisperpower.com).



### WARNING!

During installation and commissioning of the Genverter, the Safety Guidelines & Measures are applicable at all times. See chapter 2 of the user's manual.



### WARNING!

A warning symbol draws attention to special warnings, instructions or procedures which, if not strictly observed, may result in damage or destruction of equipment, severe personal injury or loss of life.



### DANGER!

This danger symbol refers to electric danger and draws attention to special warnings, instructions or procedures which, if not strictly observed, may result in electrical shock which will result in severe personal injury or loss of life.



### WARNING!

Before working (installation) on the system read the section safety instructions in the user's manual

## 1.3 INSTALLATION PARTS

Besides the parts that are included with the delivery you need at least the parts listed at section 4.4 to install the Genverter. Please note that this listing may not be complete, as every installation differs from the other. Oil is not included in the supply. Refer to the user manual for the right specifications.

## 1.4 CHP: COMBINED HEAT AND POWER GENERATION

The optimum engine operating temperature is between 80° and 110° Celsius. The outgoing oil temperature is about 90° up to 110°C. The heat exchanger reduces the temperature of the cooling liquid by 20°C to 25°C. The returning "cold" oil therefore has a minimum temperature of at least approx. 65° Celsius.

This means that the cooling circuit can be used for heating up water or any other medium to almost 100°C (optional). This can be done with an additional heat exchanger. Also it could be useful to use the hot air of the radiator for heating purposes. WhisperPower can advise on such applications and supply additional installation parts for CHP.

## 2 INSTALLATION

### 2.1 GENERAL

To ensure reliability and durability of the equipment, it is very important that the installation is carried out with the utmost care and attention. To avoid problems, such as temperature problems, noise levels, vibration, etc. the instructions set out in this manual must be followed and all installation work must be carried out professionally.

### 2.2 LOCATION

When looking for a proper place for a GV4 Piccolo in a boat all relevant aspects have to be taken into account

- Accessibility
- Solid foundation
- Space to mount the exhaust
- A route to fit the fuel lines

Since the Whisper Genverters have extremely compact dimensions, they can be installed in tight locations. Please consider that even almost maintenance-free machinery must still remain accessible.

When selecting the location area in which to mount the Genverter, make sure there is sufficient room to carry out any maintenance work. The unit must be easily accessible on the service side.

All models can be serviced from one side. Oil filling can be done on the service side and on the top. (The top of the engine (rocker cover) has to be accessible for adjustment of the valve clearance.

Please also note that in spite of the automatic oil pressure switch it is still essential that the oil level is checked regularly.

### 2.3 PROTECTION AGAINST DIRT, WATER, HIGH TEMPERATURE AND WEATHER CONDITIONS.

The unit is designed to be mounted inside a boat. The Genverter is not suited to mount on deck in the open air to be subjected to bad weathers conditions and (salt) water spray and rain or snow. The best place is a dedicated machine room.

Also inside the boat, the Genverter should be protected against bilge water, condensation, frost and other conditions that will affect the machinery. The air inlet of the engine room must be protected against the ingress of water and it is recommended

to fit an air inlet strainer for protection against dirt and dust.

### 2.4 INSTRUCTIONS FOR OPTIMAL SOUND AND VIBRATION INSULATION

Position the GV4 Piccolo as low as possible in the vessel. The Genverter is secured to the base frame inside the canopy by means of a double flexible engine mountings system. This frame is must be solidly mounted in the vessel, not using rubber mountings again. When it is possible to mount the unit directly on the vessel's frames this has advantages in preventing vibrations by resonance.

#### 2.4.1 Further recommendations

Whisper generating sets are standard equipped with a sound cover canopy. This sound cover has been designed to give effective sound insulation. For optimum sound and vibration dampening, the following factors should be considered.

1. Most important is the structure on which the Genverter is placed to be stiff. Directly below the base frame the structure should be supported vertically to the trusses of the boat. When this is not possible horizontal structures should be made stiff by additional provisions (refer to Figure 1).
2. In larger vessels a separate and insulated machine room for the Genverter will help to damp the noise even further
3. Avoid mounting the generating set in close proximity to thin walls or floors that may cause resonance.
4. Sound dampening is extremely poor if the generating set is mounted on a light weight flimsy surface such as plywood which will only amplify vibrations. If mounting on a thinner surface cannot be avoided, this should be at least be reinforced with stiffening struts or ribbing. If possible, holes should be drilled or cut through the surface to help reduce the resonance. Covering the surrounding walls and floors with a heavy coating plus foam will certainly improve the situation.
5. Never connect the base of the generating set directly to walls or tanks (refer to Figure 1).

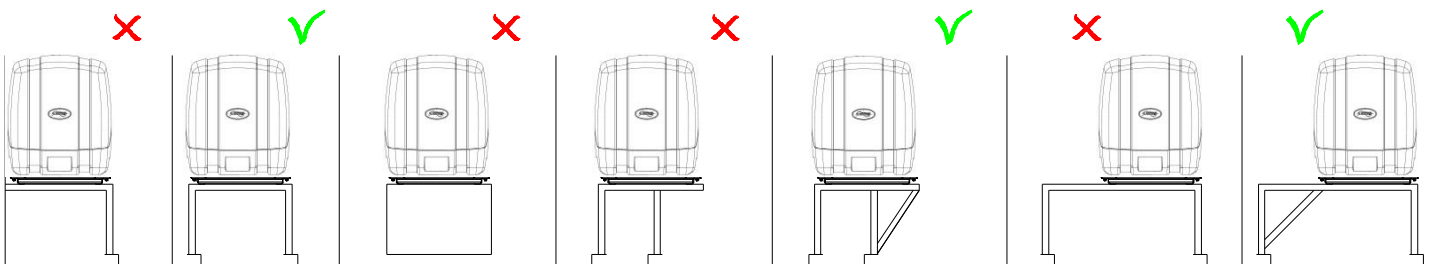

Figure 1: Mounting of a Whisper generating set. X = wrong, V = OK

## 2.5 VENTILATION

### 2.5.1 General

The Genverter normally draws air from the engine compartment or machine room. An engine compartment with natural ventilation must have vent openings of adequate size and location to enable the Genverter to operate without overheating. To allow an ample supply of air within the temperature limits of the generating set an opening of at least 100 cm<sup>2</sup> is required.

A "sealed" engine compartment must have a good extraction ventilator to maintain reasonable ambient temperatures. High temperature of intake air reduces engine performance and increases engine coolant temperatures. Air temperatures above 40°C reduce the engine power by 2% for each 5°C of rise. Further the electronic inverter is rated for 40°C. At higher temperatures the electric output will be lower. To minimise these effects the engine room temperature must not be more than 15°C above the outside ambient air temperature.

Apply a combination of ventilators, blowers and air intake ducting to meet the temperature limit. The air inlet ducts should run to the bottom of the engine compartment to clear fumes from the bilge and to circulate fresh air. Air outlets should be at the top of the engine compartment to remove the hottest air. An engine compartment blower should be used as an extraction ventilator to remove air from the engine room.

In cases where it is impossible to meet the above mentioned temperature limit by using engine compartment ventilation, connections are to be made for an air inlet directly to the Genverter enclosure.

Air inlets should be louvered, where appropriate, to protect the engine room and to protect the generating set from water spray.

## 2.6 CONNECTIONS

### 2.6.1 Overview

The Genverter GV4 Piccolo comes supplied with all supply and output lines (i.e. cooling water connections, exhaust, fuel lines etc.) already connected to the engine and inverter. The supply lines are fed through the capsule's front base.

The connections are marked as shown in Figure 2 (next page).

All electrical connections, cable types and sizes must comply with the appropriate national regulations. Supplied cables are rated for ambient temperatures up to 70°C.

If the cables are required to meet higher temperature requirements, they must be run through conduits.

## 2.7 FUEL SUPPLY

### 2.7.1 Fuel tank

Fuel tanks should be made of appropriate material such as (stainless) steel or plastic. Steel tanks should not be galvanised or painted inside. Condensation can occur in metal tanks when temperature changes. Therefore, water accumulates at the bottom of the tank and provisions should be made for the drainage of this water.

The tank will need a filling connection, a return connection and an air ventilation connection which will require protection against water entry.

Some official regulations do not allow connection points at the base of the fuel tank; connections are to be made at the top of the tank with internal tubing down to a few cm above the bottom of the tank. Using the existing fuel tank of the car-engine the fitting should be carried out with extra care. Both a supply line and a return line should be installed and go into the tank from the top. Interference of the two systems (car engine and Genverter engine) should be avoided.

### 2.7.2 Fuel lift pump

Apart from the machine fuel pump, the generating set is supplied with a separate fuel lift pump; therefore the tank can be installed at a lower level than the generating set (see Figure 3). The maximum suction height is 1 m.

If the pump has to lift the fuel higher than one meter an external fuel lift pump must be installed (Art. No. 50201062).

When using a second electric fuel supply pump, it is recommended to mount a loose supplied pump close to the tank and mount it in an angle or vertical to prevent air bubbles to block the system. The pump makes clicking noises and therefore could be mounted on rubber mountings. When the clicking noises of the pump are not acceptable another noiseless pump is available as an option (Art. No. 50202200).



#### ATTENTION!

Before working (installation) on the system read the section safety instructions.

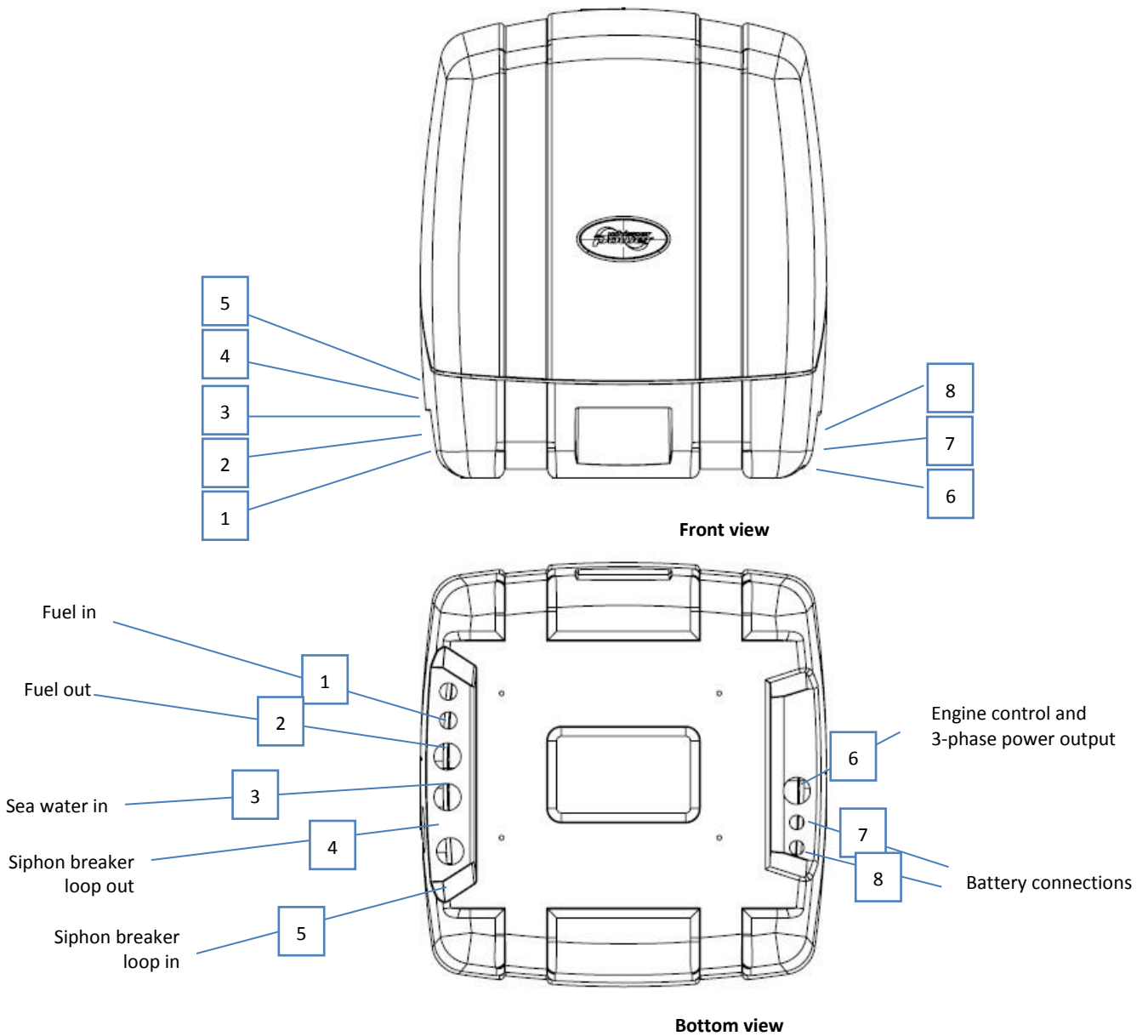

Figure 2: Connections of the GV-4 Piccolo

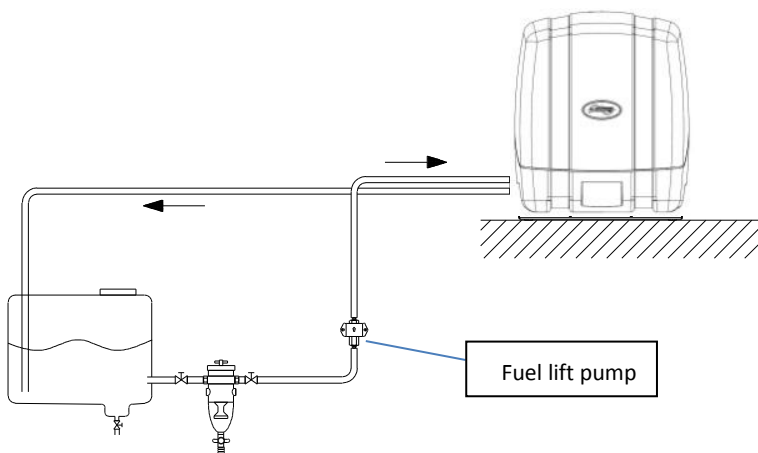

Figure 3: Fuel supply (fuel tank is below the Genverter)

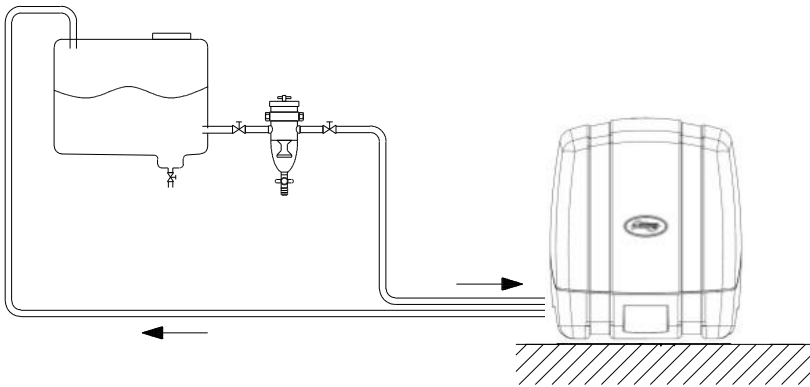

Figure 4: Fuel supply (fuel tank is above the Genverter)

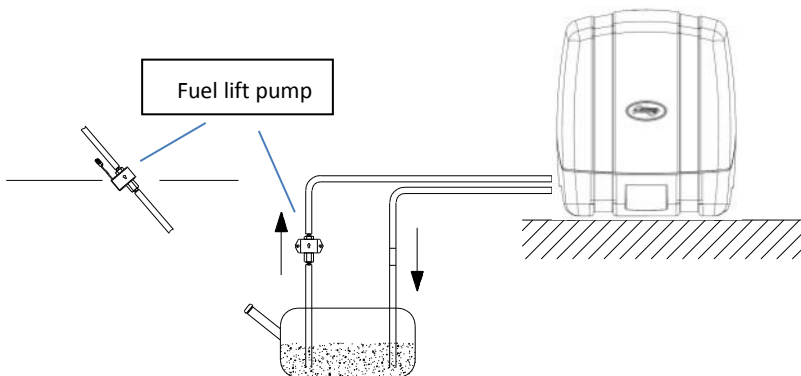

Figure 5: Fuel line assembly with fuel lift pump mounted vertically or in an angle

### 2.7.3 Fuel pipes

When the tank is above the generating set (Figure 4), WhisperPower recommends ending the return line on the top of the tank.

When the return is on the top - in case of a leakage the return line cannot overflow because of siphoning. One will only need a fuel cock in the fuel supply line. When the tank is below the generating set (Figure 3) we recommend ending the return line on the bottom of the tank (A) below the inlet of the supply line. In this way the fuel cannot drain back into the tank when the engine is stopped; as the return line will not let air in. This prevents starting trouble caused by air in the fuel supply line.

Both supply and return fuel pipe lines should be appropriate material and 8 mm outer diameter tubing. The quality of the tubing of fuel pipes could be submitted to local regulations depending on the application of the boat.

The fuel pipes can be plumbed to the flexible hoses which are on the generating set and have a connection to fit to 8 mm pipe. This fuel lines fulfils CE standards and are according to ISO 7840 A2.

It is important to avoid bends in the pipes, as they could trap air bubbles. The return pipe should never be connected to the

suction pipe. The return line should be of 8 mm diameter and go straight back to the tank. When the return is too narrow, has too many bends and goes back to the bottom of the fuel tank, the back-pressure could be too high. This results in irregular running of the engine. When the engine runs irregular, one can check if back-pressure is the problem by disconnecting the return line just outside the canopy and draining it in a canister. When the engine runs smooth now, the return piping has to be changed. It could also help to install a second (electrical 12V) fuel lift pump in the supply line to increase the pressure.

### 2.7.4 Fuel filters

A fine fuel filter is installed which requires maintenance. advises to install an extra fuel filter/ water fuel separator near the fuel tank.

Before starting your generating set for the first time follow the fuel system bleeding procedure in the user manual.

## 2.8 COOLING

### 2.8.1 General

For the cooling of an engine on a boat there are two methods available: inter-cooling and keel cooling. Inter-cooling is based on a raw water pump, heat exchanger and water-injected exhaust.

Keel cooling means cooling the coolant (in case of the GV4 Piccolo this is oil) by circulating the hot coolant through a space in the keel, or through a double walled skin of the boat, through a box cooler welded in a steel boat, using a big tank or any other external cooler.

Most of the time; using keel cooling, one apply a dry exhaust, but other combinations could be supplied on request:

- 1) Inter-cooling with water injected a wet exhaust
- 2) Inter-cooling with a dry exhaust
- 3) Keel cooling with a dry exhaust
- 4) Keel cooling with a wet exhaust

### 2.8.2 Inter-cooling

When applying inter-cooling the Genverter should have its own sea water inlet and should not be connected to any other engine systems (see Figure 6). A properly installed cooling

system is critical to keep engine temperatures within an acceptable range. Ensure that the installation complies with the following installation instructions.

### 2.8.3 Raw water supply

For raw water supply the following installation materials are required: -a skin fitting - a sea cock - a water strainer - hoses and clamps. In order to keep the suction resistance in the line at a minimum, the sea water intake system (i.e. sea cock, thru-hull fitting, inlet filter, etc.) must have an inner diameter of at least 12.5 mm diameter (1/2"). The suction hose should be kept as short as possible. Raw water plumbing should avoid bends as much as possible.

Restriction of raw water flow, caused by kinked hoses, undersized pipes or connections, will reduce the engine cooling capability. This is the main cause for overheating of an engine.

When in doubt check the coolant flow rate using a stopwatch and by holding a pail of a known volume under the wet-exhaust outlet. The flow rate should be 8 to 12 litres /min.

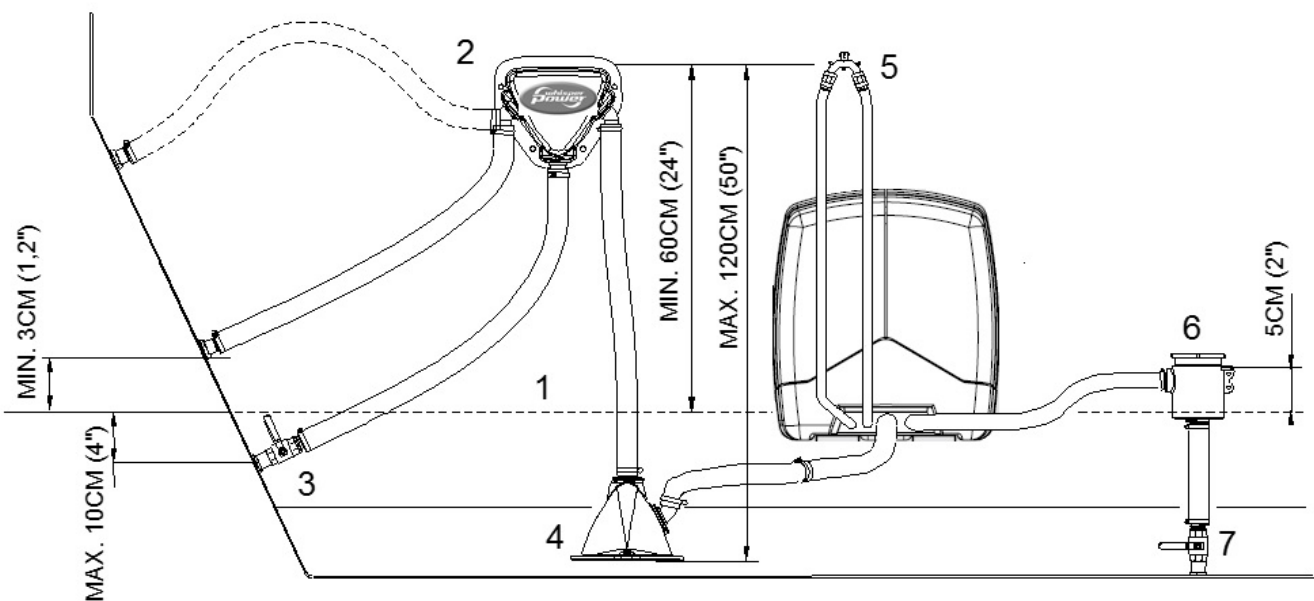

- |                           |                              |
|---------------------------|------------------------------|
| 1 Water level             | 5 Air vent (Siphon breaker); |
| 2 Water/exhaust separator | 6 Water strainer;            |
| 3 Seacock                 | 7 Seacock.                   |
| 4 Waterlock               |                              |

Figure 6: Raw water cooling system



### 2.8.4 Installation of through hull fitting

It is good practice for yachts to use a hull inlet fitting with an integrated strainer (water scoop). For propulsion engines in motorboats the water scoop is often mounted against the sailing direction to induce more water intake for cooling.

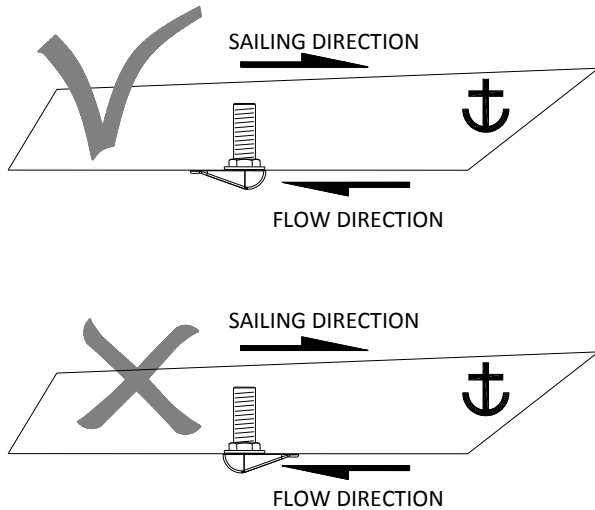

Figure 7: Installing water intake



THIS SHOULD NOT BE DONE IN THE CASE OF A GV4 Piccolo OR ANY OTHER GENVERTER! WHEN SAILING AT HIGHER SPEEDS, WATER WILL BE FORCED INTO THE INLET AND YOUR ENGINE WILL OVERFLOW!

See Figure 7. On motorboats and on sailing boats the water scoop for a GV4 Piccolo should be fitted with the opening faced backwards to prevent water being forced in during sailing. Use a sealant when mounting the skin fitting.

### 2.8.5 Water strainer

Use an appropriate water strainer with connections of 12.5 mm (1/2"). Install the water strainer in a well accessible position, (refer to Figure 6, ref 6) 5 cm above the waterline.

### 2.8.6 Siphon breaker (air vent)

When the point of water injection is below the waterline, then - when the engine is stopped -there is a risk that the cooling water may enter the engine as a result of siphoning. To avoid this happening, the GV4 Piccolo is designed to accommodate a siphon breaker (air vent). In the standard delivery of the GV4 Piccolo connections are bypassed. Hose of 12.5 mm (1/2") inner diameter should be used.

If the GV-4 cannot be mounted such that the bottom of the GV-4 is placed above the waterline, an air vent must be installed. Extend the water hose of the by-pass 60 cm above waterline and install an air vent. Ideally, the air vent should be mounted

above the yacht keel centre line (i.e. to minimize the influence of swaying on the water intake).

Fast motorboats will lay deeper when sailing at large speed (non-planing) and have additional pressure on the water inlet. This should be avoided to prevent water from entering into the engine.



If the air vent is clogged the water hoses will not be vented when the GV-4 has stopped and water can be forced into the engine. this leads to immediate engine problems and eventually severe damage!



DAMAGE CAUSED BY THE INGRESS OF WATER IN THE ENGINE IS NOT COVERED BY WARRANTY.

The siphon breaker that is delivered with the Whisper Power siphon breaker installation kit does not require a connection for a hose to drain the little water that could be spilled from the valve. If you use another kind of siphon breaker that has a hose connection, make sure that the drain should go downwards down directly and that it may not end under water. Water must flow out freely and air has to flow in freely as well (refer to Figure 8).

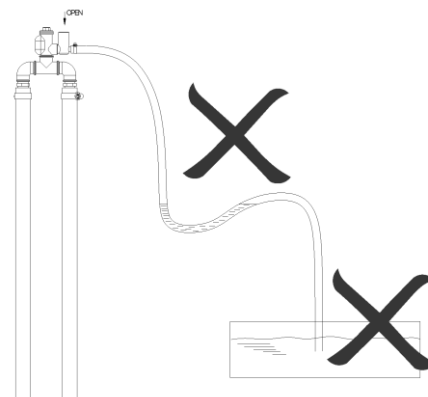

Figure 8: Wrong siphon breaker hose routing (non-Whisper Power siphon breaker)

Check the air vent at regular intervals. Open, clean and lubricate the valve as required (Figure 8).

## 2.9 EXHAUST SYSTEM

Inter-cooling is almost always combined with a wet exhaust system: Water is injected in the exhaust system of the Genverter. In this way the cooling water that has passed the heat exchanger is mixed with the exhaust gases. Temperature and volume of the gases are thereby reduced considerably, so that a rubber exhaust hose can be used and the level of noise is reduced as well.

However a dry exhaust is possible dumping the water over board separately.

Keel cooling is almost always combined with a dry exhaust.

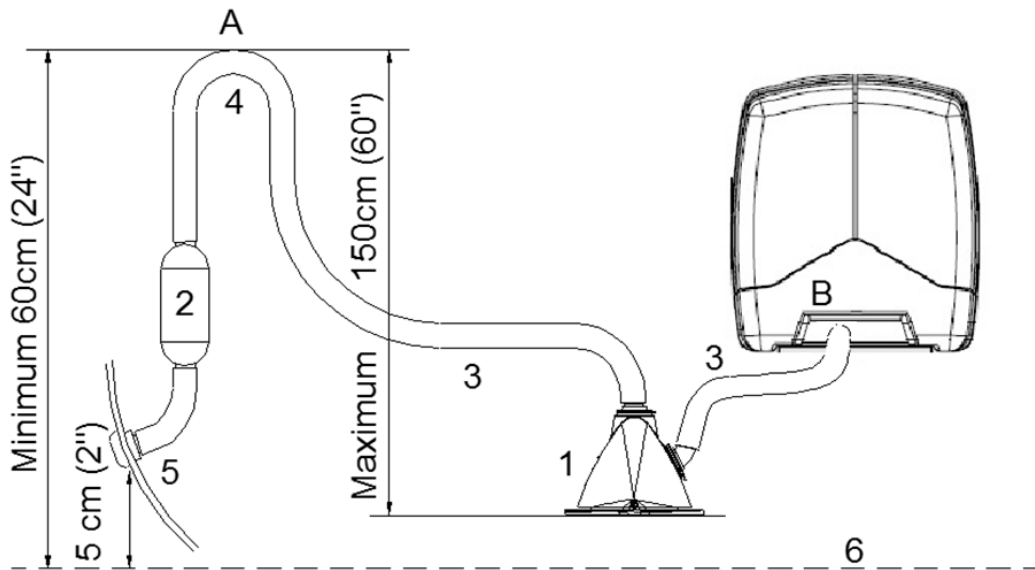

Figure 9: Standard exhaust system

- |                                     |  |
|-------------------------------------|--|
| 1 Exhaust water lock;               | 4 Goose neck;                                      |
| 2 Exhaust outlet muffler;           | 5 Through-hull exhaust outlet $\varnothing$ 40 mm; |
| 3 Exhaust line $\varnothing$ 40 mm; | 6 Water level.                                     |

### 2.9.1 Standard wet exhaust system installation

The Genverter wet exhaust system must remain completely independent and separate from the exhaust system of any other engine on board. A water lock prevents the Genverter from being flooded by cooling water and should be installed as close to the Genverter as possible. The lock must be large enough to hold the entire water volume held in the hose from the top of the goose neck to the water lock. The water lock must be installed at the lowest point of the exhaust system (refer to Figure 9, ref. 1). The exhaust hose must have an inner diameter of 40 mm no less, no more-. The exhaust system must be installed so that the back pressure inside the exhaust does not exceed 0,8 psi 60 cm. water pressure (refer to the user's manual) and total length up to the outlet or water separator does not exceed 2,5 m. The exhaust hose descends from the capsule to the water lock. Then the hose rises maximum lift 120 cm via the "goose neck" to the through-hull exhaust outlet, situated minimum 50 mm above the water line (refer to Figure 6, ref. 5). The "goose neck" must be vertical and situated preferable along the ship's keel centre line. It is recommended to install an extra muffler (see Figure 9, ref. 2) close to the through-hull fitting.



Because of the small gas flow of the small engine it is very important to keep strictly to the instructions above. some mufflers and water locks cause too high back pressure. It is recommended to use a WhisperPower installation kits or check the back pressure (refer to the user's manual). Too high back pressure causes the system to fill up with water affecting the outlet valve and valve seat.

### 2.9.2 "Super silent" exhaust system

See Figure 10. In order to reduce the noise level of the GV4 Piccolo to a minimum, an option to reduce the exhaust noise further (especially exhaust water splashing) is an exhaust/water separator. The exhaust/water separator allows the cooling water to be ejected through a line separate from the exhaust fumes and also functions as a goose neck to prevent water from flooding the engine. The exhaust/water separator is mounted more than 60 cm above the water level.

See Figure 11. If the through-hull exhaust outlet has to be mounted far from the GV4 Piccolo, an exhaust/water separator must definitely be installed. (Total length of the exhaust piping from Genverter to top of goose neck (water separator) is more than 2,50 m.) The sea water from the separator must run down along the shortest possible path to the through-hull outlet.

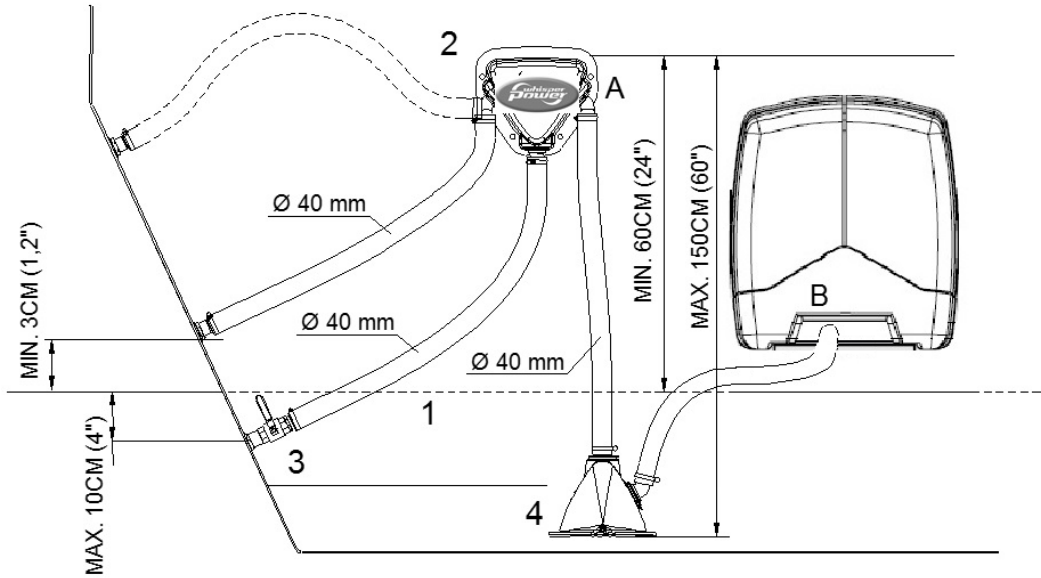

Figure 10: Super silent exhaust system

1 Water level	2 Water/exhaust separator	3 Seacock
		4 Waterlock

Only when using an exhaust /water separator the exhaust may have a length up to 7,5m after the water/gas-separator. However water traps should be avoided as the fumes still contains water and this should not accumulate in bends (refer to Figures 12 and 13). An additional outlet exhaust muffler close to the hull outlet will help further to reduce noise emission.

If the M-GV4 Piccolo and the exhaust system have been installed correctly, neighbouring boats will not be disturbed by

outlet noise. With the "super silent" exhaust system, GV-4 noises are almost inaudible. For optimal noise reduction, the sea water outlet from the exhaust/water separator (centre outlet on the unit) should be installed below the water level to eliminate noisy splashing of the effluent sea water.

The through-hull outlet for the exhaust fumes should not direct the fumes directly toward the water surface as this will cause excessive noise (refer to Figure 14).

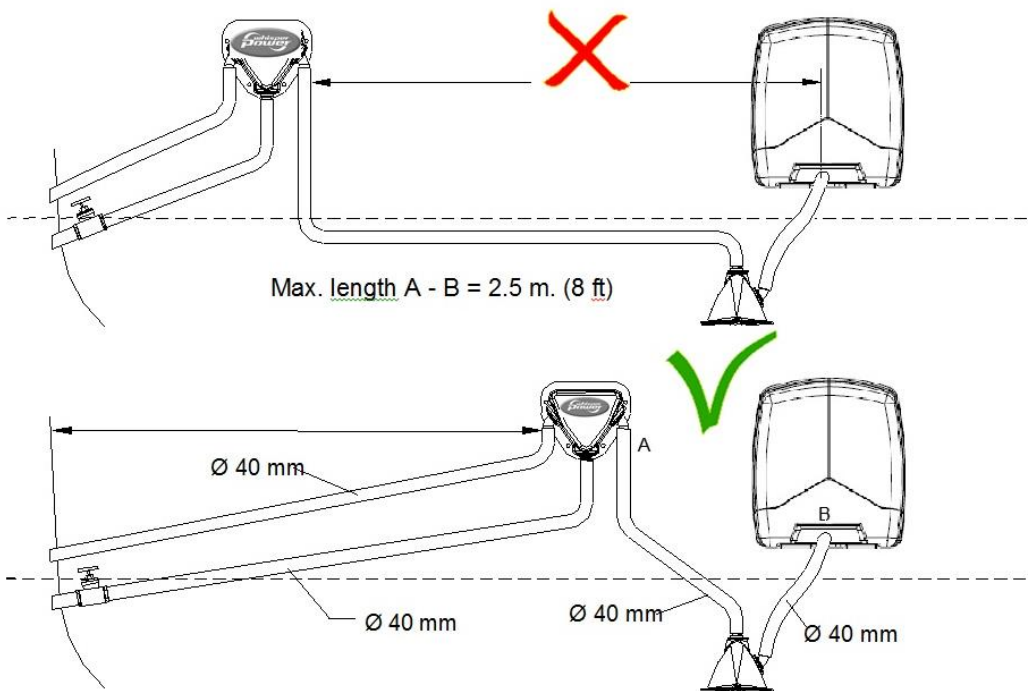

Figure 11: Install the water lock close to the generator

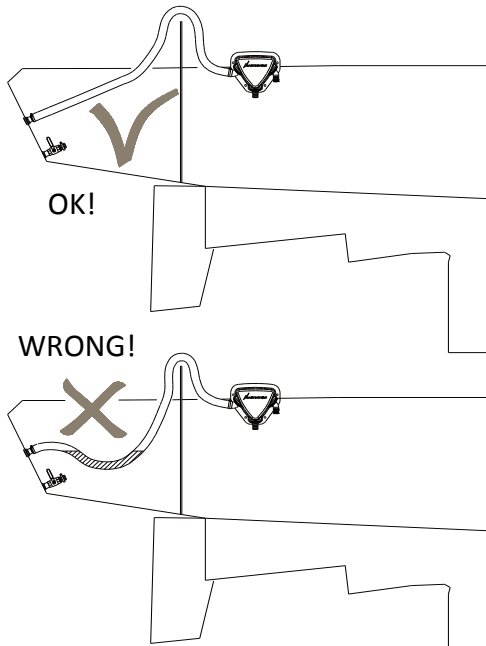

Figure 12: Water trap in exhaust system

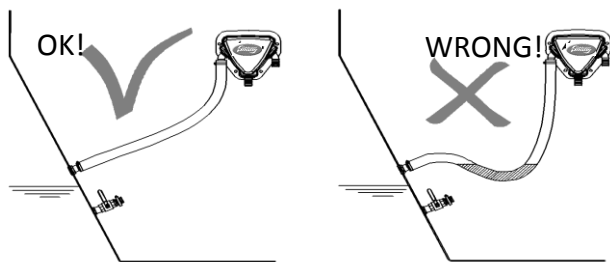

Figure 13: Water will collect in the hanging bend of the exhaust gas hose and will cause back pressure

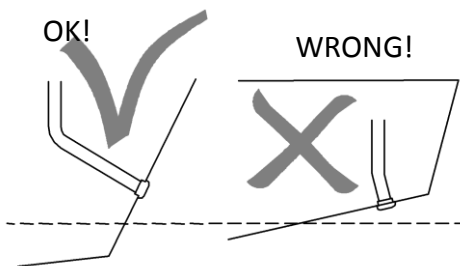

Figure 14: Outlet direction



Do not direct the outlet directly toward the water surface.

## 2.10 DRY EXHAUST SYSTEM

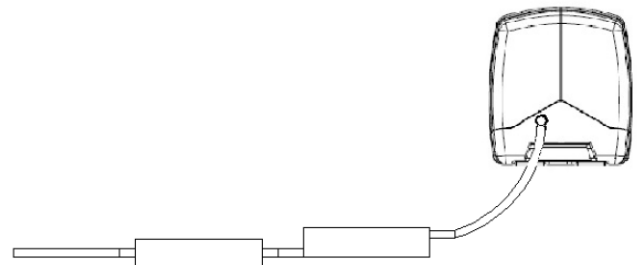

Figure 15: Dry exhaust systems on boats

### 2.10.1 General remarks

A dry exhaust muffler system should be very effective in silencing exhaust noises when applying the right mufflers. However noise could be generated by vibrations in the mufflers and be transferred to the boat. Tacit factors like the length of specific pipe sections could cause the noise to be amplified. It is very difficult to take these factors into account.

The standard Whisper Power exhaust kit contains the materials to perform a professional installation. In the kit is a stainless steel flexible bellow (hose) to allow for expansion and to prevent vibrations to be transferred.

Rubbers are supplied to mount the mufflers flexible. The insulation jacket for the flexible bellow and the resonance muffler are also very effective in damping vibrations. Still it could be that additional measures has to be taken like an extra clamp in a vibrating section of pipe, insulation blankets on other parts of the system and possibly even additional mufflers.



When the exhaust is led through the roof of a boat, measures has to be taken to prevent rainwater to enter the system. Special rain caps are available as an option.

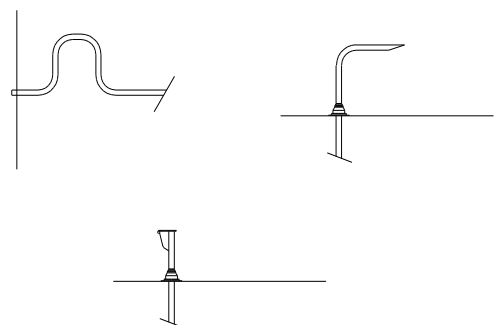

Figure 16: Ways to prevent water from getting in

A negative feature of a dry exhaust system is the heat radiated by its components. Measures must be taken to overcome the heat problem: When a dry exhaust has its outlet on the deck or on the roof of the steering house, all the pipes inside the boat has to be insulated.



THE EXHAUST PIPES WILL BE VERY HOT AND ALL ACCESSIBLE PIPES AND MUFFLERS ARE DANGEROUS TO PEOPLE WHEN NOT INSULATED.

There are companies that are specialised in insulating hot pipes and fancy systems are available to make it good looking. However it is also possible to do it yourself by winding fibreglass or Rockwool around the pipes and seal it with aluminium tape. On request Whisper Power can supply insulation jackets for all kind of pipes and bends.

## 1 THE STANDARD DRY EXHAUST SYSTEM

The standard exhaust system contains:

On the Genverter:

- An insulated exhaust bend

In the exhaust installation kit:

- A stainless steel shielded flexible bellow.
- One resonance muffler
- One absorption muffler
- Clamps and rubbers to mount the system flexible
- Fittings, bends and pipes to make the different connections
- Jackets for thermal and sound insulation.

The mufflers are high quality marine mufflers that are much more effective, robust and durable than mufflers made for automotive use.



WHEN THE EXHAUST IS LED THROUGH THE SIDE, DECK OR ROOF OF THE DECK HOUSE, MEASURES HAS TO BE TAKEN TO PREVENT RAINWATER TO ENTER THE SYSTEM. SPECIAL RAIN CAPS ARE AVAILABLE AS AN OPTION.

### INSTALLATION OF THE DRY EXHAUST

Before determining the location of the Genverter set one has to consider how to get away with the exhaust. In wind still

conditions a light smell of exhaust fumes around the boat will not be avoidable.

To bring the exhaust to the deck or to the top of the deck house gives the best results on noise and smell. However, when the pipes go through the boat they should be insulated and around the hole in the deck or roof should be a collar to prevent rainwater to leak in. Both mufflers could be on the roof or one of them or both could be in the machine room.

In general it is better to have the mufflers wide apart: the resonance muffler close to the Genverter and the absorption muffler on the end of the line. A short pipe (30cm) should be on the far end after the absorption muffler. The absorption muffler has no flow direction and could be mounted both ways. The resonance muffler should be mounted according to the indication on the muffler itself.



The resonance muffler should be fitted according to direction of the gas flow indicated.

In the kit are clamps to mount the exhaust pipes to stainless steel bars. These bars should be mounted to the structure of the boat. It is recommend to use rubber mountings whenever possible. However take care that the heat conducted through the brackets will not affect the rubber. Refer to Figure 17 how to mount the rubber in a safe way. When any doubt an extra safeguard could be constructed from steel wire or chain.

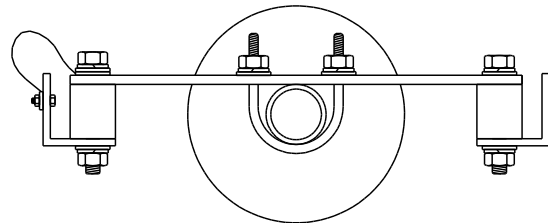

Figure 17: Mounting bracket in rubber with safeguard

### 3 ELECTRICAL INSTALLATION (12 VOLT)

#### 3.1 ENGINE CONTROL SYSTEM

Engine control (standard 12V) is incorporated in the PMG Power Module for Genverter. Use the PMG or a separate DDC box to operate the generator.

#### 3.2 STARTER BATTERY

For starting, the GV4 Piccolo requires a 12V starter battery with at least 55 Ah.

The GV4 Piccolo can be connected with the main engine battery or have its own battery.

We strongly recommend the use of a separate battery for the GV4 Piccolo and to keep the wiring system for the boat engine and the domestic DC supply system completely separate and individually connected to separate batteries.

However, the negative of all the batteries on the boat should be interconnected to avoid difference in the voltage level of the earth on different places causing trouble to electronic devices which might be in the system.

The above recommendation is not valid for boats having the starter battery of the boats engine or other auxiliary equipment positive grounded. When this is the case an expert should be consulted.

A battery switch may be used to interrupt the positive connection.

The starter battery is charged by the alternator on the engine. An additional battery charger will help to keep the battery in good condition when the generating set is not used.

A battery charger is not included in the standard supply. A high efficiency battery charging unit can be ordered from Whisper Power which is able to charge both the boat's main battery and the starter battery. Also a small charger can be used to charge the starter battery only.

#### 3.3 OTHER RECOMMENDATIONS AND WARNINGS

The battery should be secured for rough sea conditions and the terminals should be insulated. For extra safety the battery can be enclosed in a wooden, plastic, fibreglas etc. (non metal) box. Even when the earth return system is applied a negative battery cable should be used and the boat should not to be used as a conductor.

Battery cables are not included (recommended: 1.5 m , 10mm<sup>2</sup>; if longer cables are required a larger cross sectional area should be considered to compensate for voltage reduction). Connect the cables as described in section 4.1.



When two batteries are used in series to provide a 24 Volt supply system, never take off 12 Volt (starting) power from one of these batteries. This will result in severe damage to both batteries within a short time.

Disconnect the battery leads if electrical welding is to be carried out, otherwise damage will be caused to the diodes of the alternator.



As explosive hydrogen gases may be discharged during charging, the battery should be located in a well-ventilated room. Ensure that the supplied battery cable connectors are properly fitted and never remove during or shortly after charging as sparking can occur, which may ignite the hydrogen gasses.

#### 3.4 AC POWER SYSTEM (230 VOLT)



The electric power supplied by the GV4 Piccolo is of a high voltage and dangerous to people. Before working (installation) on the system read the sections on safety in the users manual.



Generators used on boats that are operated in a hazardous environment have often to fulfil special regulations and additional measures have to be taken accordingly.

Be sure that all electrical installations (including all safety systems) comply with all required regulations of the local authorities. All electrical safety/shutdown and circuit breaking systems have to be installed on board as the generating set itself cannot be equipped with such equipment for every possible variation.

The boats power supply system should be suitable and safe for the AC voltage which is applied and the power that will be generated. Special attention has to be paid on dividing the system in branches which are fused individually.

It is absolutely essential that each and every circuit in the electrical system is properly installed by a qualified electrician.

#### 3.5 CABLE PROTECTION (FUSES)

It is the installer's responsibility to protect the live wires between the genverter and the PMG/DC PowerCube. Check the electrical information on the identification plate in order to calculate the right fuse size.

Please note that the above is in addition to any fuses required between the PMG/DC PowerCube and the AC installation or batteries, as applicable.

### 3.6 GROUNDING

The AC alternator windings are not grounded.  
The housing of the alternator and all other metal parts are grounded.

It is necessary that the electric installation in the boat must be protected against insulation failures. Methods of protection are subjected to rules that can be different depending on the use of the boat and local standards.  
Experts in this field should be consulted.

To make a connection between “neutral” and “ground” is necessary as part of a specific insulation failure protection system. In the GV 4 this connection is NOT made in the factory. Do not make this connection without installing this specific insulation protection system!

### 3.7 CABLE

For the power cable we recommend the use of 4 wire three phase oil resistant cable with a sufficient cross sectional area. One wire for earth is included. For long cables it is recommended to apply cables with a larger cross section (refer to ISO 13297 annex A).

### 3.8 TRANSFER SWITCH

A power source selector switch must be installed between the PMG box and the vehicle’s electrical supply system. This switch must ensure that all AC consumers can be switched off at once. This switch should also be installed to keep the generating set and “land” (grid) power systems separate.  
Transfer switches - to switch over from a land line to vehicle or from generating set to inverter - should be well designed to switch over all wires including neutral (and not only phases or line) and there should be provisions with the aid of timers to prevent relays from clattering.

Whisper Power recommends the installation of a Systemswitch as the power source selector. This works automatically when the generating set is not running the input remains in the land line position and as soon as the generating set is running the Mass Systemswitch switches automatically after 10 seconds delay time over to the generating set position.



In all situations the transfer switches between land line, inverter and Genverter should switch both neutral and L1.

## 4 INSTALLATION SPECIFICATIONS

### 4.1 GENERAL

- 1 Mount the generating set directly, without additional vibration dampers, on a solid surface.
- 2 Mount the cooling system for the engine
- 3 Connect exhaust system.
- 4 Connect 'fuel supply line' to the water separator/ fuel filter.
- 5 Connect 'fuel return line' to the fuel tank.
- 6 Connect remote panel (just plug in).
- 7 Connect the AC cable from the AC box to the power source selector.
- 8 Connect the battery cables to the starter motor as illustrated in Figure 21 :

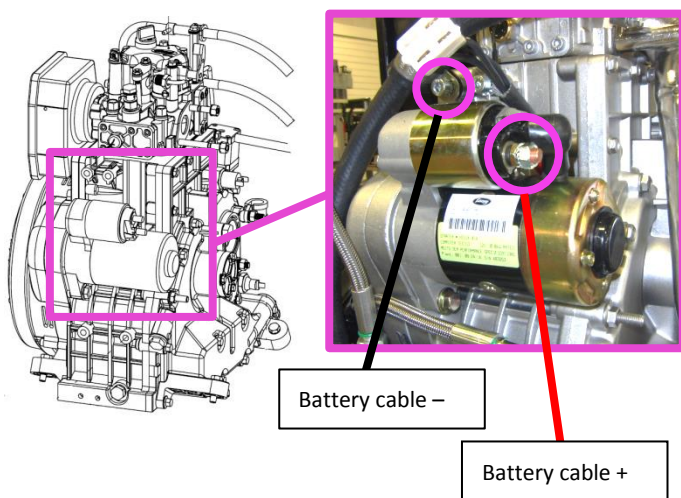

Figure 21: Connecting the battery cables to the starter motor

- 9 Connect plus and minus from the 12V starter battery to the battery cables.
- 10 Install a Whisper Power battery charger (optional).

### 4.2 COMMISSIONING TABLE

- 1 Check if the cooling system for the engine is properly installed.
- 2 Check if the exhaust system is properly installed. Check maximum length of exhaust hose, diameter of exhaust piping.
- 3 Check all coolant connections.
- 4 Check the AC cables and the grounding.
- 5 Check if an AC breaker is installed before or after the power source selector. When there is only a circuit breaker, use it to disconnect the generating set from the grid.
- 6 Check all DC connections, check if the battery switch/ circuit breaker is closed.
- 7 Open the fuel valve. Check if there are no air leaks in the fuel supply line, and check if the lift of the fuel is less than 1 meter. Check if there is no air in the water fuel separator.
- 8 Check if the air intake in the canopy is not blocked.
- 9 Check the oil level and colour of the oil.
- 10 To bleed the fuel system:  
Push the "Start" button on the local control (not on the remote panel) and hold at least 5 seconds and as long as necessary to bleed the system.
- 11 Start the engine by pushing the start button
- 12 Check when the Genverter is running, the delay of some seconds in the power source selector transfer.
- 13 Check voltage and frequency under 'no load' conditions.
- 14 Check if the Genverter increase speed when loaded more. Check if the Genverter can bring the full load.
- 15 Check if the Genverter can speed up when largest load step that can occur comes in. If not increase no load speed (Refer to DDC manual)
- 16 Check if the battery charger of the generating set is working (max. 14.5 Volt).
- 17 Close the sound shield and check the noise level.
- 18 Stop the Genverter set and check the engine again for leakages of oil, fuel or coolant and check the oil level again.

Installation checklist available on our website:

[www.whisperpower.com](http://www.whisperpower.com).

Commissioning form available on our website:

[www.whisperpower.com](http://www.whisperpower.com).

### 4.3 TECHNICAL DATA

Refer to the M-GV 4 Piccolo User Manual for an overview of general technical specifications.



#### 4.4 SPECIFICATION OF THE ACCESSORIES

Water scoop	min. 1/2" (recommended 3/4")
Inlet valve	min. 1/2" in 12.5 mm out (recommended 3/4" in 12.5 mm out)
Water strainer	12.5 mm in, 12.5 mm out
Anti-siphoning valve	12.5 mm
Inlet suction hose	12.5 mm
Exhaust hose in/out	Ø 40 mm (1 5/8")
Water lock	Ø 40 mm (1 5/8")
Water/gas separator	Ø 40 mm (1 5/8")
Starter battery	55 Ah
Fuel filter/water separator	30 micron
Fuel inlet and return	8 mm

#### 4.5 INSTALLATION MATERIALS

##### FUEL KIT

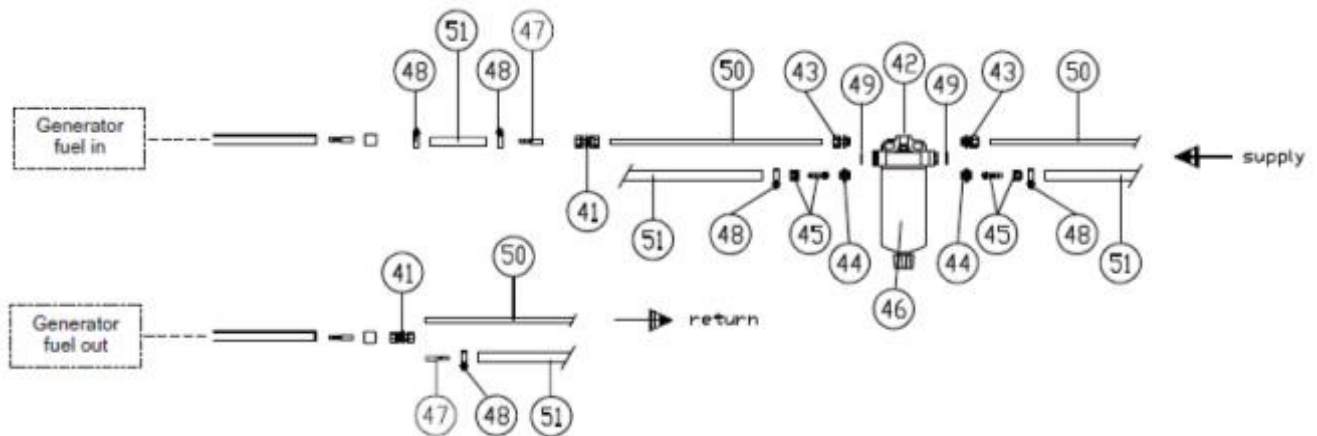

Figure 22: Fuel supply kit

no	qty	article no	description	dimensions
41	2	50221203	Straight coupling	8 mm
42	1	40230090	Fuel strainer/water separator	M14x1.5 mm
43	2	50221618	Parallel male stud coupling	M14 - 8 mm
44	2	50221644	Reducing male nipple	M14-M16 60 gr.
45	2	50221615	Hose connection	8 mm
46	2	50221616	Nut coupling	M16x1.5 mm
47	1	50221252	Nipple hose pipe	8 mm
48	4	50221522	Hose clamps	10-16 mm
49	2	50221632	Gasket ring	14x20x1.5 mm
<b>TOTAL</b>		<b>40230205</b>	<b>FUEL KIT</b>	

##### OPTIONAL INSTALLATION MATERIALS

no	qty	article no	description	dimensions
50	1	50222020	copper fuel pipe	6x8 mm
51	1	50220063	fuel hose	8x16 mm

- Spare parts fuel kit

pos.	qty	article no	description
46		40230092	Filter for strainer fuel/water separator

**WATER INLET KIT**

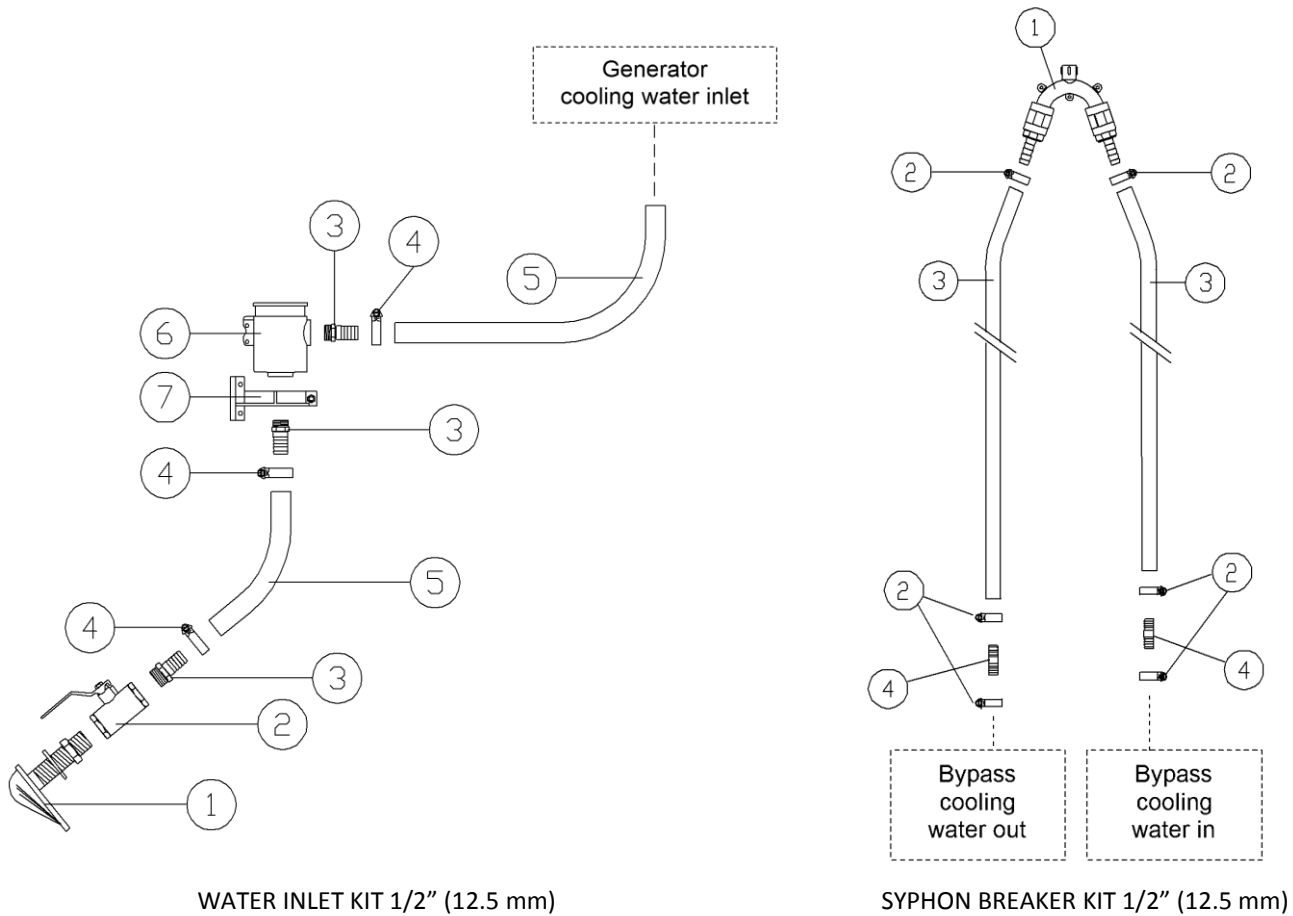

WATER INLET KIT 1/2" (12.5 mm)

SYPHON BREAKER KIT 1/2" (12.5 mm)

Figure 23: Water inlet kit and syphon breaker kit

**WATER INLET KIT 12.5 mm**

pos.	qty	article no	description
1	1	50230052	Intake strainer 3/4"
2	1	50230042	Lever operated ball valve FF 3/4"
3	3	50221016	Male hose connection 3/4"x13
4	3	50221521	Hose clamp stainless 12-20
5	3m	50220055	Cool. water hose transp. spiral 13x19mm
6	1	50230062	Nickel plated brass intake strainer 3/4"
7	1	50230067	Mounting bracket small water strainer 1158
<b>TOTAL</b>		<b>40230201</b>	<b>WATER INLET KIT 12.5 mm</b>

**SYPHON BREAKER KIT 12.5 mm**

pos.	qty	article no	description
1	1	50230017	Siphon breaker valve 12.5mm (1/2"), complete (including valve assembly)
2	6	50221521	Hose clamp stainless 12-20
3	3m	50220057	Cooling water hose warm water 13x21mm
4	2	50221260	Hose connector 12.5mm (1/2")
<b>TOTAL</b>		<b>40230272</b>	<b>SYPHON BREAKER KIT 12.5 MM (1/2")</b>

**WET EXHAUST KIT**

According to ABYC recommendations all hose connections must be fitted with two hose clamps  
 Maximum torque hose clamps: 12Nm / 105 InLbs

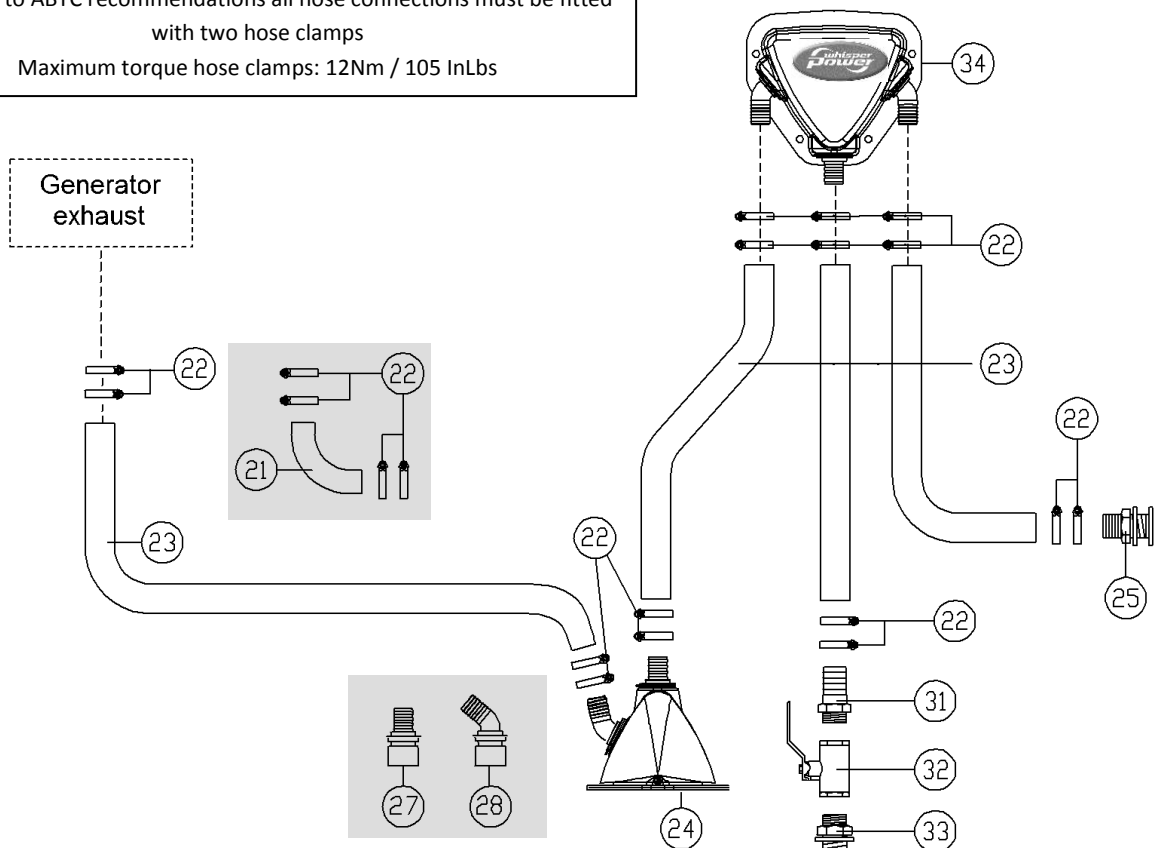

Figure 24: "Delta" exhaust kit  $\varnothing$  40 mm (1 5/8") and water separator kit 40 mm (1 5/8")

**"DELTA" EXHAUST KIT  $\varnothing$  40 mm (1 5/8")**

pos.	qty	article no	description
22	8	50221504	Hose clamp stainless 32-44 mm
23	3m	40220033	Marine exhaust hose 40 mm (1 5/8")
24	1	40230093	Waterlock 40 mm Delta
25	1	50230038	Brass hull fitting hose connection 1 1/4"x40
<b>TOTAL</b>		<b>40230251</b>	<b>DELTA EXHAUST KIT 40 mm</b>

**"DELTA" WATER SEPARATOR KIT 40 mm (1 5/8")**

pos.	qty	article no	description
22	8	50221504	Hose clamp stainless 32-44 mm
23	2.5m	40220033	Marine exhaust hose 40 mm (1 5/8")
31	1	50221015	Male hose connection 1 1/4" x 40mm
32	1	50230044	Lever operated ball valve FF 1 1/4"
33	1	50230033	Brass through hull fitting 1 1/4" x 70
34	1	40230197	Water / gas separator Delta 40/40/40mm (1 5/8")
<b>TOTAL</b>		<b>40230093</b>	<b>Delta water/gas separator kit 40mm</b>

**OPTIONAL INSTALLATION MATERIALS**

pos.	qty	article no	description
21	1	50230087	Elbow 90° adapter exhaust hose
22	4	50221504	Hose clamp stainless 32-44 mm
27	1	50230113	Straight coupling Delta 40mm
28	1	50230112	Elbow (45°) Delta 40mm

**DRY EXHAUST KIT**

Figure 25: Dry exhaust kit

**DRY EXHAUST KIT 1"**

no	qty	article no	description
61	1	ST 50220041	Exhaust hose 500mm SS male/female 1"
62	1	ST 50220042	Insul. blanket 35x60 exhaust hose 1 1/2
63	1	ST 50230520	Absorption muffler steel 1"
64	1	ST 50230521	Resonance muffler steel 1"
65	1	ST 50230522	Insulation blanket R-muffler 1"
66	2	ST 50221401	Pipe nipple 1"x300mm galvanised
67	2	ST 50221421	Parallel male coupling 1" galvanised
68	2	ST 50221411	Straight coupling f/f 1" galvanised
69	3	ST 50221661	U-clamp 42mm M10
70	3	ST 50221664	Bracket U-clamp 25cm M10/48mm passivated
71	6	ST 50211406	Washer SP M10
72	6	ST 50211447	Washer spring SP M10
73	6	ST 50211466	Nut hexagonal SP M10
75	1	ST 50221471	Elbow 90 degr m/f galvanised 1"

**BATTERY INSTALLATION KIT**

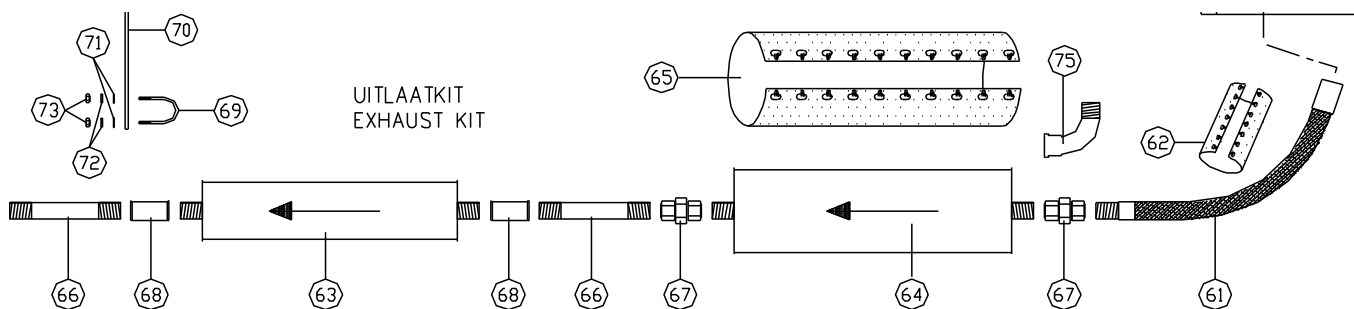
article no	description	dimensions
61112002	WBC-Handy 20 charger 12V / 2A	157 x 33 x 34 mm
40290093	battery terminal (NEG-)	
40290094	battery terminal (POS+)	
40290099	M8 battery pole adapter set	
40290098	isolation caps (red&black)	
502144701	WP-Compact Manual Battery Switch, 300A	72 x 72 x 78 mm
<b>40290106</b>	<b>INSTALLATION KIT FOR BATTERIES UP TO 100 Ah</b>	

**RECOMMENDED BATTERY**

article no	description	dimensions
40290060	AGM-Power 12V 55Ah Absorbed Glass Matt	229 x 138 x 210 mm

## 5 DIAGRAMS & DRAWINGS

### 5.1 ELECTRICAL DIAGRAMS

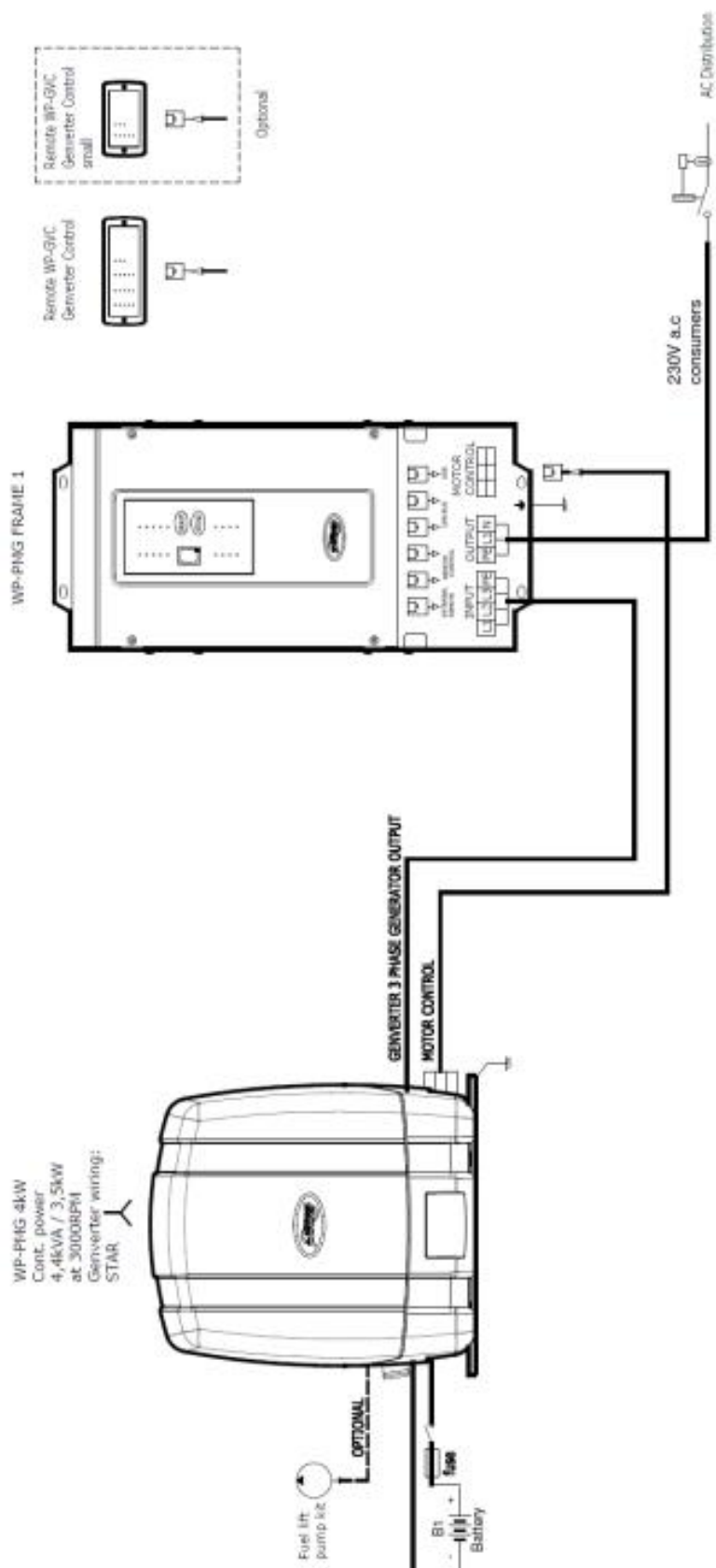

Figure 26: Electrical control diagram

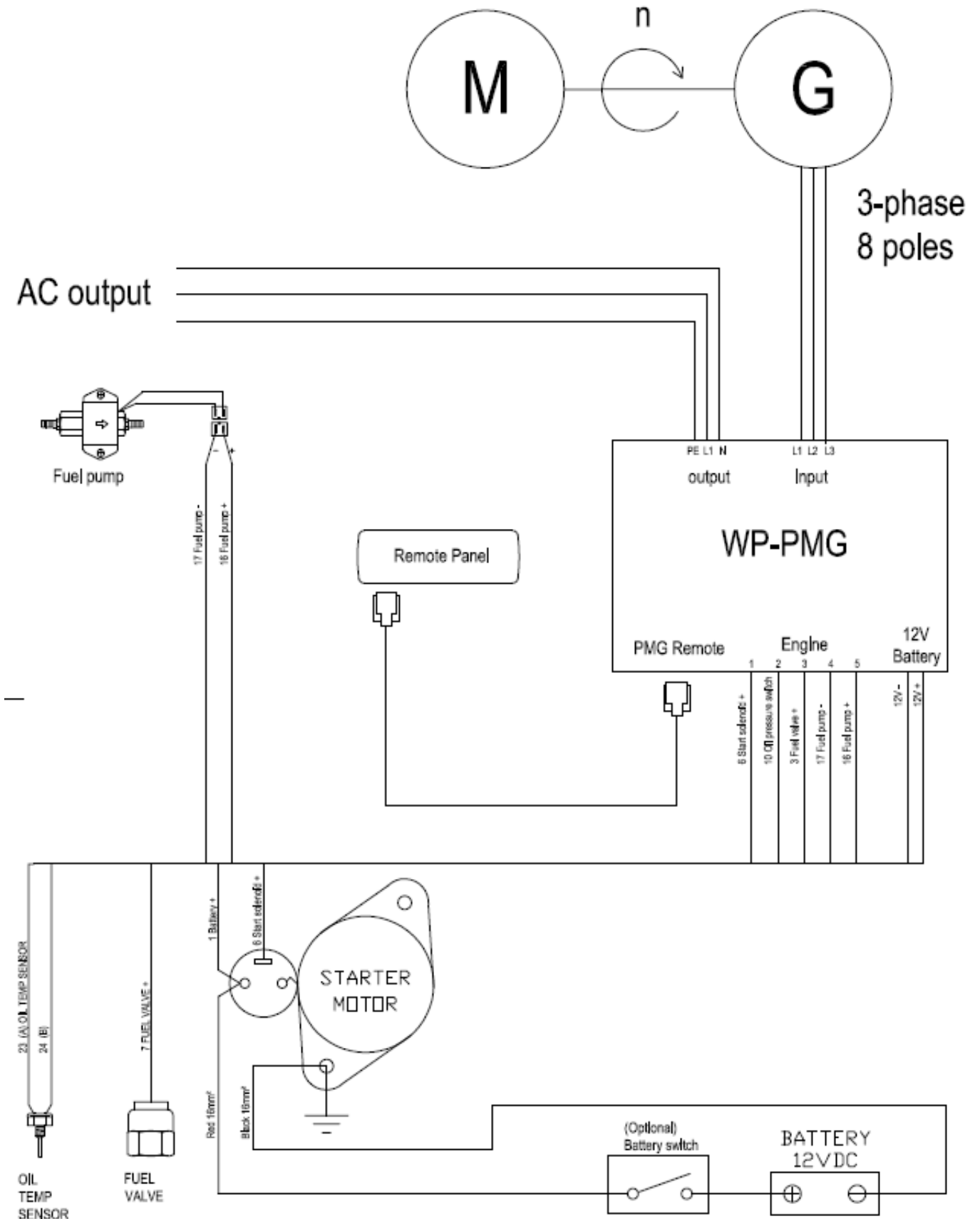

Figure 27: Electrical wiring diagram

## 5.2 MECHANICAL DRAWINGS

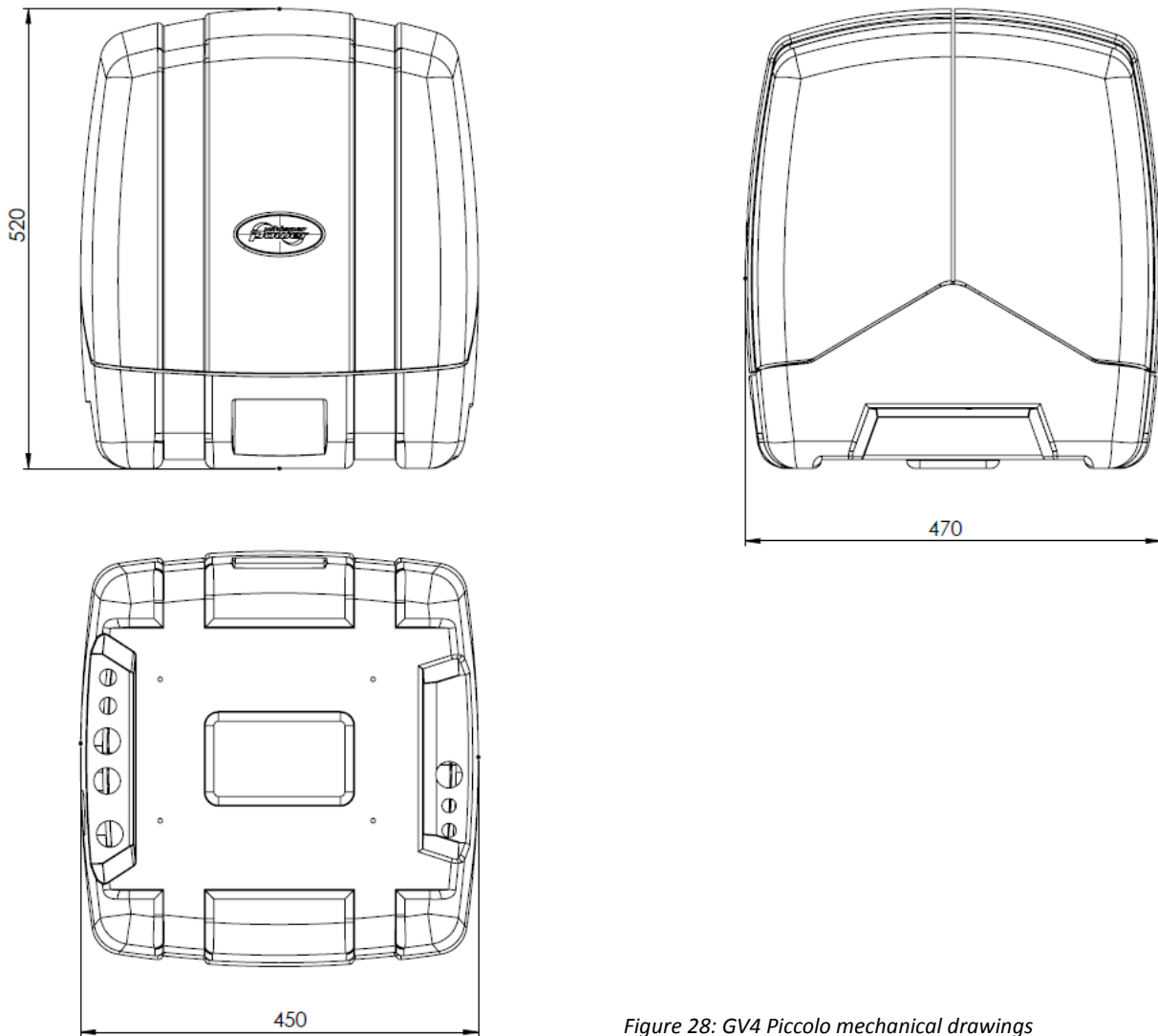

Figure 28: GV4 Piccolo mechanical drawings



Kelvinlaan 82, 9207 JB Drachten, Netherlands  
Tel : + 31-512-571550 / Fax : + 31-512-571599  
[www.whisperpower.com](http://www.whisperpower.com) / [info@whisperpower.com](mailto:info@whisperpower.com)